

Low Power 60GHz mmWave Sensor Evaluation Module



Description

The IWR6432AOPEVM is an easy-to-use, low cost FR4-based evaluation board for the IWR6432AOP mmWave sensing device, with standalone operation and direct connectivity to the DCA1000EVM for raw ADC capture and signal processing development. This EVM contains everything required to start developing software for on-chip hardware accelerator and low power ARM® Cortex®-M4F processor.

Features

- Wide field of view antenna, targeted for wall mount and ceiling sensing applications
- FR4-based PCB substrate
- XDS110 JTAG interface with USB connectivity for code development and debugging
- Power optimized discrete DCDC power management design
- Serial port for onboard QSPI flash programming
- 60-pin, high-density (HD) connectors for raw analog-to-digital converter (ADC) data

- Onboard CAN-FD transceiver
- Onboard INA228 for ultra-precise digital power monitoring
- USB powered standalone mode of operation

Applications

- **Industrial:**
 - Automated door and gate
 - Motion detector
 - Occupancy detection (people tracking, people counting)
 - Video doorbell
 - IP network camera
 - Air conditioner
 - Refrigerators and freezers
 - Lawn mover
 - Portable electronics
 - Televisions
 - Home theater and entertainment

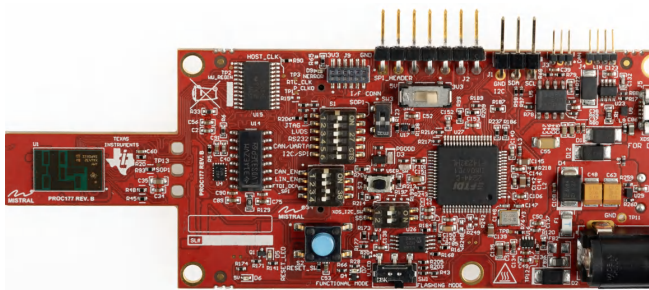

IWR6432AOPEVM (Top View)

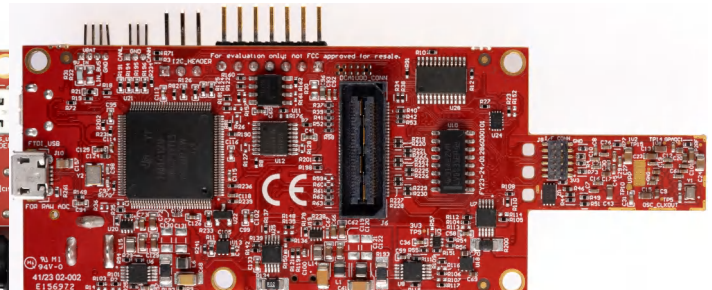

IWR6432AOPEVM (Bottom View)

1 Evaluation Module Overview

1.1 Introduction

The IWRL6432AOP Evaluation Module (EVM) offered by Texas Instruments presents an easy to use and cost-effective platform for assessing the capabilities of the IWRL6432AOP mmWave sensing device. Designed with an FR4-based PCB substrate, this evaluation board has seamless integration with the DCA1000EVM for direct connectivity, facilitating raw ADC capture and signal processing development. With a focus on user-friendliness and versatility, the EVM can operate in stand alone mode and includes all features that streamline the initiation of software development for on-chip hardware accelerators and low-power ARM® Cortex® M4F processor.

Key attributes of this EVM include a wide-field-of-view AOP (antenna on package), specifically crafted for wall-mount, and ceiling sensing applications. For efficient code development and debugging, the EVM is equipped with a USB-connected XDS110 JTAG interface. The inclusion of a power-efficient discrete DC-DC regulators enhances overall energy efficiency. Additionally, the EVM incorporates a serial port for programming the onboard QSPI flash and features a 60-pin high-density (HD) connector designed for the capture of raw ADC data from the mmWave radar device.

To facilitate code debugging and data capture, the EVM incorporates an FTDI chip configured for SPI-based raw data capture. The EVM has the INA228 high precision current sensors which have remarkable accuracy, measuring current accurately up to micro-amperes. Operating in an independent mode powered via USB, and with an on board 16 MB QSPI flash, this EVM stands as a comprehensive design for developers keen on exploring the potential of the IWRL6432AOP mmWave sensing device.

1.2 Kit Contents

IWRL6432AOPEVM kit includes the following:

- IWRL6432AOP Evaluation board
- Micro USB cable
- Quick Start Guide
- Warranty card (disclaimer sheet)
- Head Screws
- Hexagon Spacers
- Plain Washers

1.3 Specification

The IWRL6432AOPEVM includes two transmitters and three receivers antenna on package with a wide field of view antennas. The IWRL6432AOP mmWave sensor is an essential part of this evaluation module, operating in a 6.5GHz bandwidth between 57GHz and 63.5GHz. The IWRL6432AOP evaluation module is specifically designed for the IWRL6432AOP mmWave sensing device, with standalone functionality and seamless connectivity to the DCA1000EVM for direct raw ADC capture

The IWRL6432AOPEVM has a wide range of industrial applications, including automated door/gate systems, IP network cameras, thermostats, air conditioners, vacuum robots, freezers, refrigerators, people tracking, people counting, video doorbells, PCs/notebooks, portable electronics, televisions, tablets, earphones, smart watches, gaming devices, home theater and entertainment systems.

1.3.1 Block Diagram

[Figure 1-1](#) shows the functional block diagram. The mission board (sensor area) side contains the essential components for the TI radar system namely Crystal Oscillator, Serial FLASH and TI mmWave Radar chip. The expandable area contains the Power Distribution Network, on board XDS110 USB to UART converter, FTDI chip, 60-pin connector for interfacing with the DCA1000EVM.

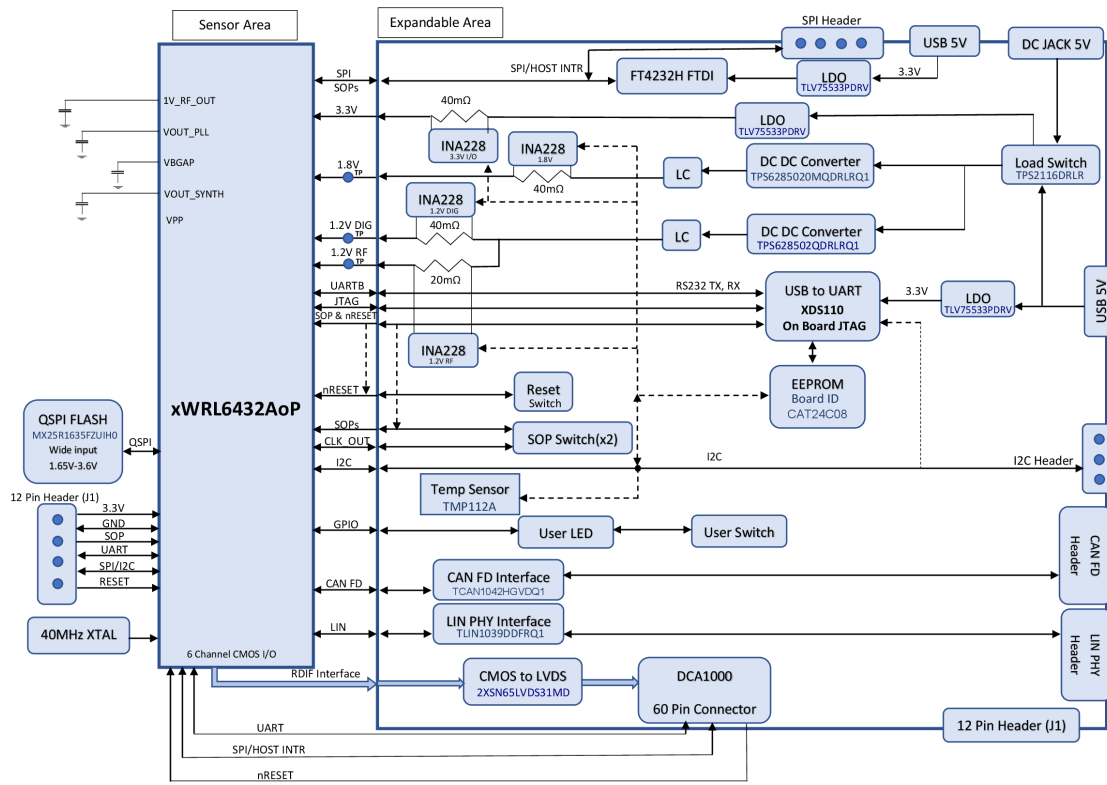

Figure 1-1. Block Diagram of the IWRL6432AOPEVM

1.3.2 EVM Mux Block Diagram

Figure 1-2 shows different muxing options for the digital signals. The device is pin limited to support different features simultaneously; hence various internal IPs and signals are pin multiplexed. EVM provides de-muxing options using various analog mux and sliding switch options. Figure 1-2 shows different muxing switch positions to enable different muxing options to connect to different peripherals.

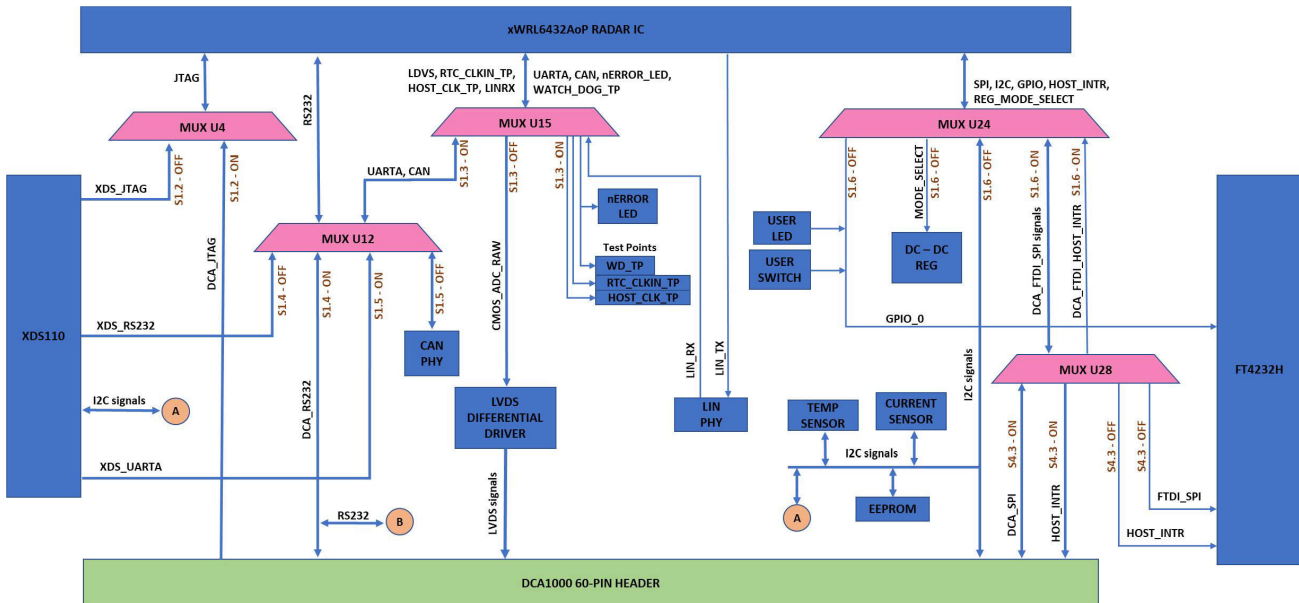

Figure 1-2. Muxing Options for the EVM

1.4 Device Information

The IWRL6432AOP mmWave Sensor device is an Antenna-on-Package (AOP) device that is an evolution within integrated single chip mmWave sensor based on FMCW radar technology. The device is capable of operation in the 57GHz to 63.5GHz band and is partitioned into mainly four power domains:

- **RF/Analog Sub-System:** This block includes all the RF and Analog components required to transmit and receive the RF signals.
- **Front-End Controller sub-System (FECSS):** FECSS contains ARM Cortex M3 processor, responsible for radar front-end configuration, control, and calibration.
- **Application Sub-System (APPSS):** APPSS is where the device implements a user programmable ARM Cortex M4 allowing for custom control and automotive interface applications. Top Sub-System (TOPSS) is part of the APPSS power domain and contains the clocking and power management sub-blocks.
- **Hardware Accelerator (HWA):** HWA block supplements the APPSS by offloading common radar processing such as FFT, Constant False Alarm rate (CFAR), scaling, and compression.

IWRL6432AOP is specifically designed to have separate knobs for each of the above-mentioned power domains to control the states (power ON or OFF) based on use case requirements. The device also features the capability to exercise various low-power states like sleep and deep sleep, where low-power sleep mode is achieved by clock gating and by turning off some of the internal IP blocks of the device. The device also provides the option of keeping some contents of the device, like application image or RF profile retained in such scenarios.

Additionally, the device is built with TI's low power 45-nm RF CMOS process and enables unprecedented levels of integration in an extremely small form factor. IWRL6432AOP is designed for low power, self-monitored, ultra-accurate radar systems in the industrial applications.

1.5 IWRL6432AOPEVM Antenna

The IWRL6432AOPEVM includes three receiver and two transmitter short range antennas on the package of the chip. [Figure 1-3](#) shows the antenna on package.

Note

Do not have any taller components in the Field Of View (FOV) of the antenna to avoid any multipath reflection. Have a keep out area of at least one wavelength (5mm) from either edge of the device.

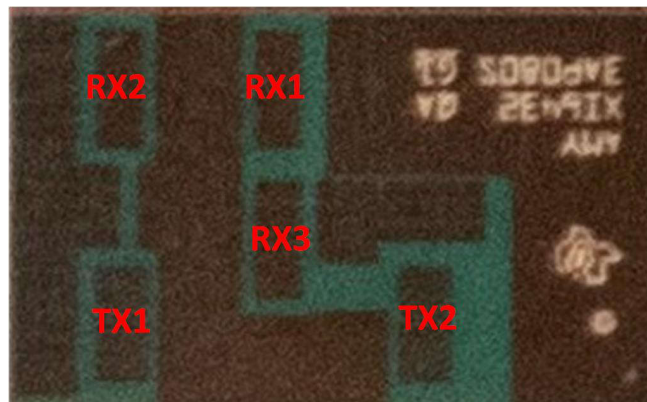

Figure 1-3. AOP Antennas

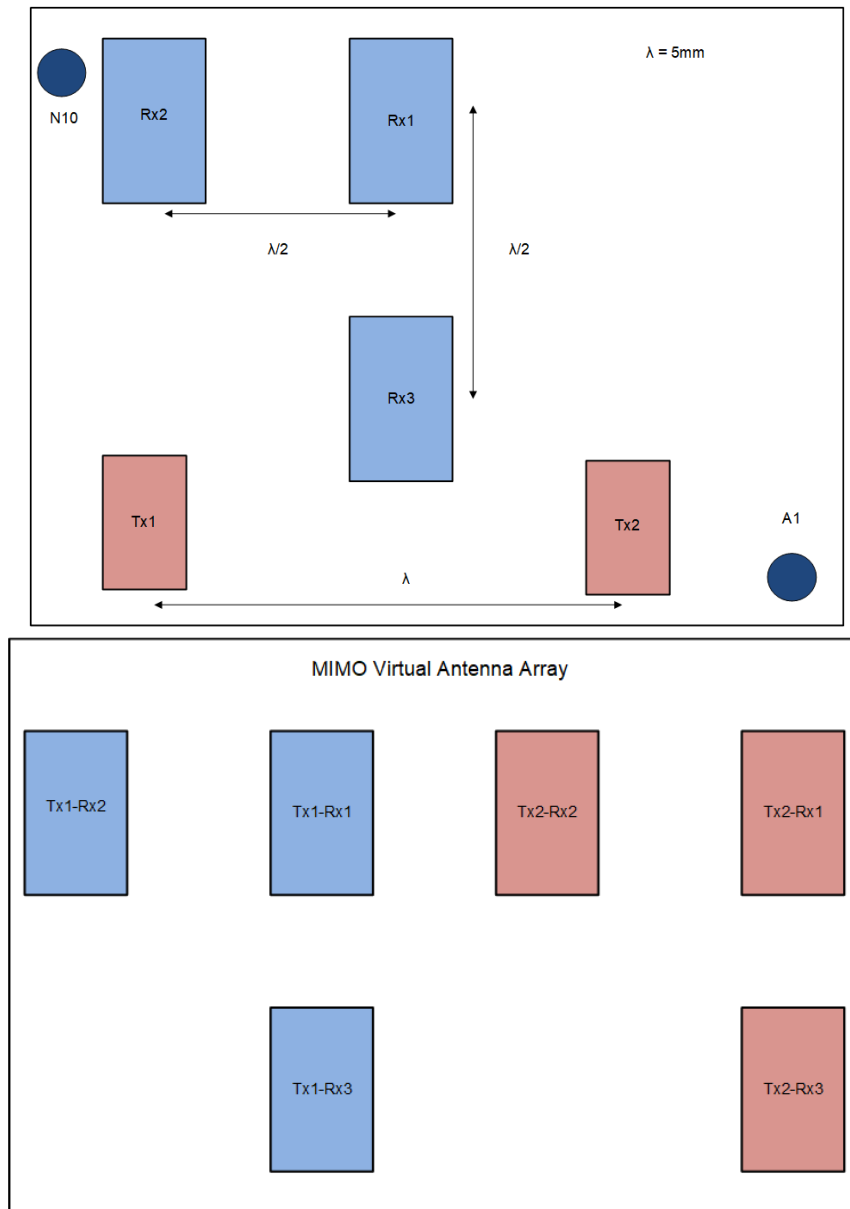

Figure 1-4. IWRL6432AOP Antenna Placement MIMO Array

2 Hardware

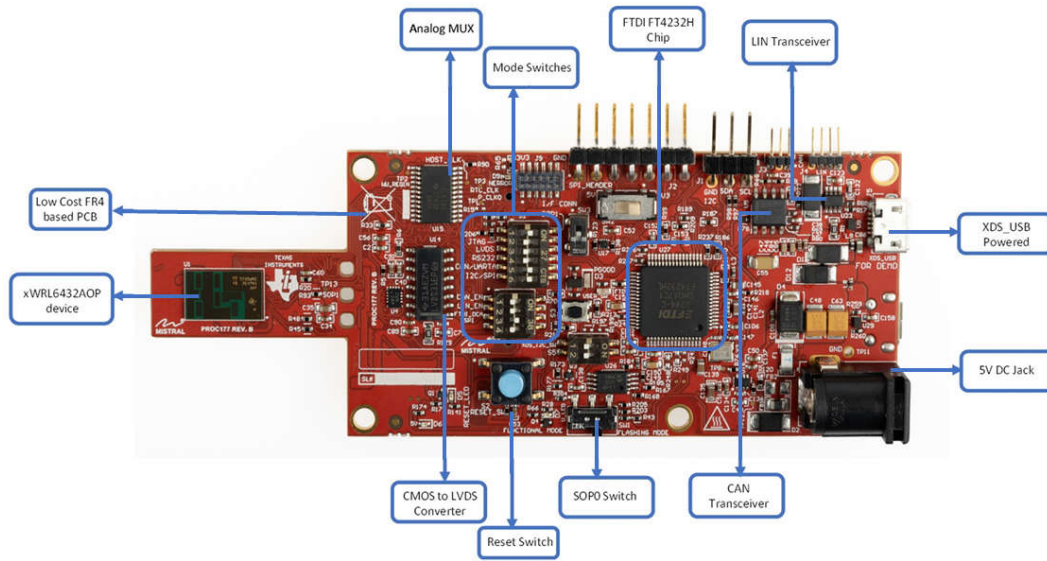

Figure 2-1. Salient Features of EVM (Top side)

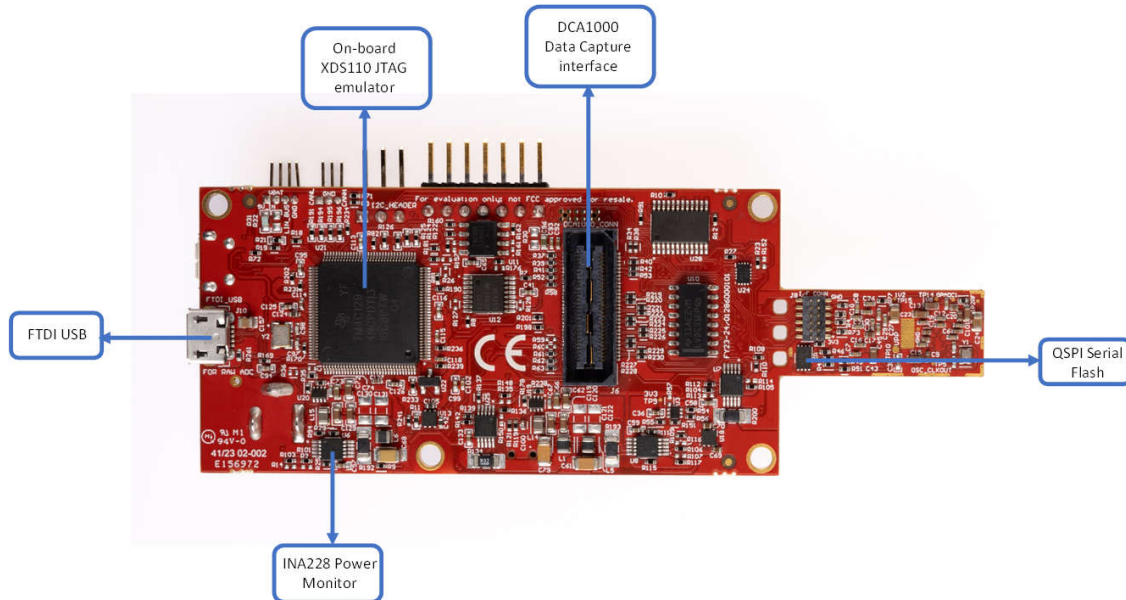
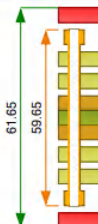

Figure 2-2. Salient Features of EVM (Bottom side)

2.1 PCB Material

Material used for this PCB is regular FR4 based Iteq IT180A Prepreg 1080 RC65 for the PCB layers.

Layer	Stack up	Description	Processed Thickness	Isolation Distance (Summed)	Copper Coverage	ϵ_r	Impedance ID	Supplier Description	Tg
1		ELECTRA EMP 110/5410- RED	1.000			4.000		EMP 110/5410	
		Copper Foil 12 microns	1.850		100.000			HI-Q Foil	
2		Iteq IT180A Prepreg 1080 RC65-NEW	2.328	4.656		3.860		IPC-4101E / 99/ 101/ 126	170.000
		Iteq IT180A Prepreg 1080 RC65-NEW	2.328	-		3.860		IPC-4101E / 99/ 101/ 126	170.000
3		Iteq IT180A 47 mil core 2/2	2.638		52.000				
		Iteq IT180A 47 mil core 2/2	41.600	41.600		3.770		IPC-4101E / 99/ 101/ 126	170.000
4		Iteq IT180A Prepreg 1080 RC65-NEW	2.638		43.000				
		Iteq IT180A Prepreg 1080 RC65-NEW	2.209	4.419		3.860		IPC-4101E / 99/ 101/ 126	170.000
		Iteq IT180A Prepreg 1080 RC65-NEW	2.209	-		3.860		IPC-4101E / 99/ 101/ 126	170.000
		Copper Foil 12 microns	1.850		100.000			HI-Q Foil	
		ELECTRA EMP 110/5410- RED	1.000			4.000		EMP 110/5410	

2.2 Switches and LEDs

2.2.1 SOP Configuration

Table 2-1. SOP Configuration

	SOP0(SW1)	SOP1(S1.1)
Flashing	OFF	OFF
Functional	ON	OFF
Debug	ON	ON

Note

The *Debug* mode selection is for the IWRL6432AOP device debug bypassing the bootloader and not for code debug. For code debug, functional mode must be used.

2.2.2 Switches

Table 2-2 shows the list of push buttons and usage.

Table 2-2. Switches Information

Reference Designator	Usage	Comments	Image
SW1	SOP0	Switch between Functional and Flashing mode	 Figure 2-3. SW1 Switch
S1.1	SOP1	OFF : Flashing / Functional Mode ON : Debug Mode	 Figure 2-4. S1 Switch
S1.2	JTAG	OFF : XDS_JTAG ON : DCA_JTAG	
S1.3	RDIF	OFF : RDIF ON : LIN_RX, XDS_UARTA/CAN, NERROR_LED, WATCH_DOG_TP, HOST_CLK_TP	
S1.4	RS232	OFF : XDS_RS232 ON : DCA_RS232	
S1.5	CAN/UARTA	OFF : CAN ON : XDS_UARTA	
S1.6	I2C/SPI	OFF : I2C, REG_MODE, LED_SW_GPIO ON : SPI	

Table 2-2. Switches Information (continued)





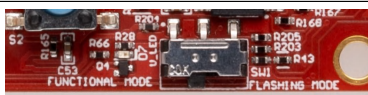
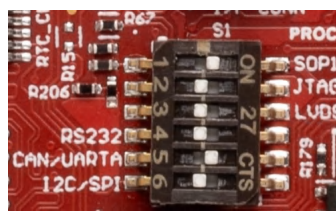

Reference Designator	Usage	Comments	Image
S4.1	CAN Enable	OFF : CAN PHY : Stand-by Mode Disable ON : CAN PHY : Stand-by Mode Enable	 <p>Figure 2-5. S4 Switch</p>
S4.2	LIN Enable	OFF : LIN PHY : Enable ON : LIN PHY : Disable	
S4.3	FTDI/DCA SPI	OFF : FTDI_SPI ON : DCA_SPI	
S5.1	XDS SDA	OFF : XDS_SDA Disable ON : XDS_SDA Enable	 <p>Figure 2-6. S5 Switch</p>
S5.2	XDS SCL	OFF : XDS_SCL Disable ON : XDS_SCL Enable	
S2	RESET Switch	Bounce Switch	 <p>Figure 2-7. S2 Switch</p>
S3	USER Switch	Bounce Switch	 <p>Figure 2-8. S3 Switch</p>
SW2	Reference Design Connectivity Switch	Switch between 5V and 3.3V : To supply 5V to reference design (Only required when reference design is connected on EVM)	 <p>Figure 2-9. SW2 Switch</p>
SW3	Reference Design Connectivity Switch	OFF : Switch low to put reference design into Flashing Mode (as shown in image) (Only required when reference design is connected on EVM)	 <p>Figure 2-10. SW3 Switch</p>

Table 2-3 provides the list of LEDs and usage.

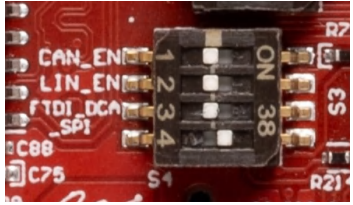
Table 2-3. LEDs Information

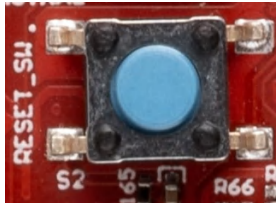
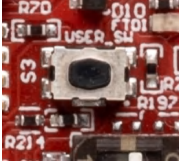
Reference Designator	Color	Usage	Comments	Image
D3	YELLOW	PGOOD	3V3 supply indication	 <p>Figure 2-11. D3</p>
D5	GREEN	nRESET	This LED is used to indicate the state of nRESET pin. If this LED is glowing, then the device is out of reset. This LED glows only after the 5V supply is provided.	 <p>Figure 2-12. D5</p>
D6	GREEN	POWER	This LED indicates the presence of the 5V supply.	 <p>Figure 2-13. D6</p>
D7	GREEN	USER LED	Customer programmable user LED. Note: Switch S3 settings are needed to enable this.	 <p>Figure 2-14. D7</p>
D9	RED	NERROUT	Glowing if there is any HW error in the mmWave sensor device.	 <p>Figure 2-15. D9</p>
D10	YELLOW	FTDI	Glowing if the USB is in suspend mode	 <p>Figure 2-16. D10</p>

2.3 DC Jack

Higher current support: When using the EVM with the external power adapter, the 5V supply is provided by the external power adapter. For most of the use cases, this external power supply option is not used, as power is derived from the USB interface.

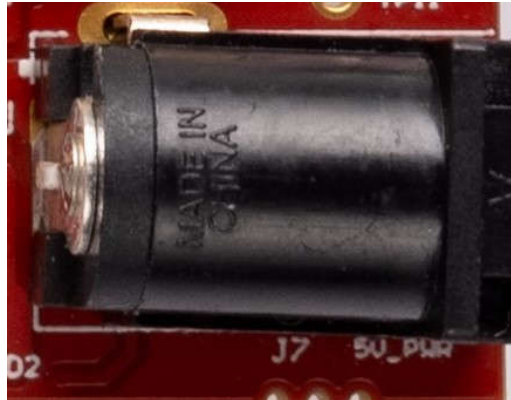

Note

After the 5V power supply is provided to the EVM, TI recommends pressing the NRST switch one time to verify a reliable boot-up state.

Note

All digital IO pins of the device (except NRESET) are not fail safe; hence, care needs to be taken that the pins are not driven externally without the VIO supply being present to the device.

2.4 DCA1000 HD Connector

The 60-pin HD connector shown in [Figure 2-17](#) provides the high-speed data and controls signals (SPI, UART, I2C, NRST, NERROR, and SOPs) to the DCA1000.

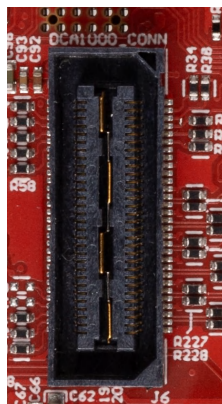

Figure 2-17. DCA1000 HD Connector

2.5 CANFD Connector

The CAN FD connector provides access to the CAN_FD interfaces (CAN_L and CAN_H signals) from the onboard CAND-FD transceiver. These signals can be directly wired to the CAN bus.

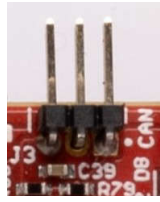

Figure 2-18. CANFD Connector

The J3 connector shown in Figure 2-18 provides the CAN_L and CAN_H signals from the onboard CAND-FD transceivers (TCAN1042HGVDQ1). These signals are wired to the CAN bus after muxing with the SPI interface signals; one of the two paths must be selected. CAN signals are selected to PHY by changing the switch S1.5 to off position.

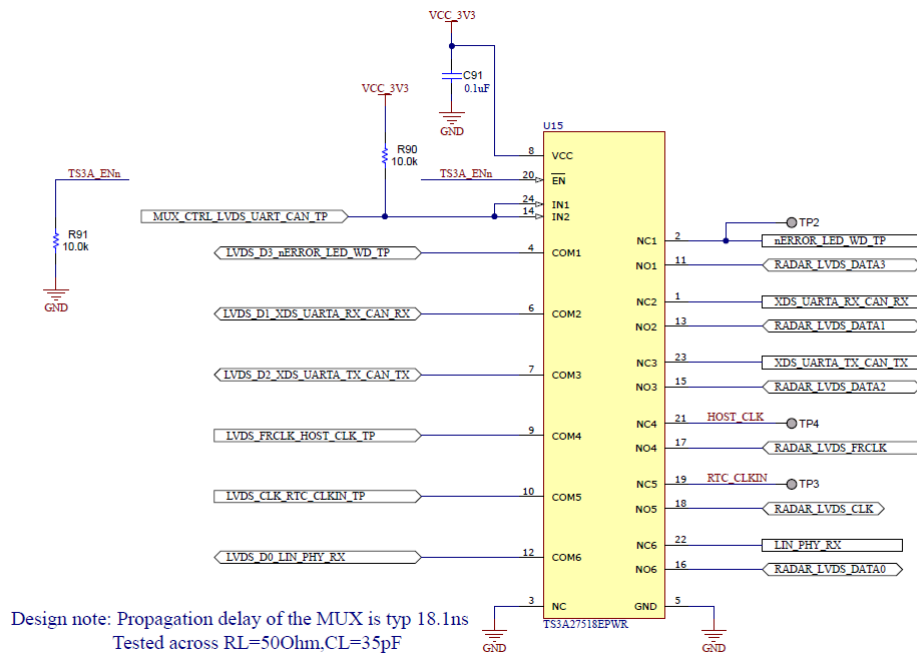

Figure 2-19. Analog Mux for the CAN PHY Switch

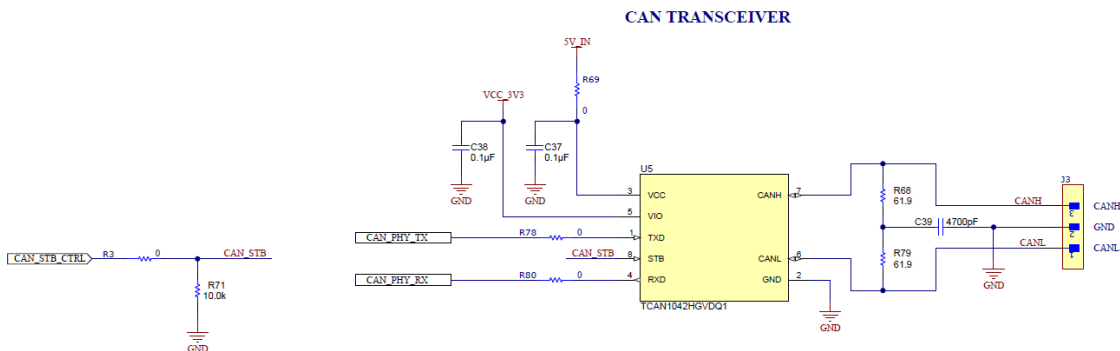

Figure 2-20. CAN FD PHY Used in the EVM

2.6 LIN PHY Connection

Figure 2-21 shows the LIN PHY (TLIN1039DDFRQ1) interface to the device. There are no switches for the LIN PHY interface. LIN PHY can operate with different supply voltage than the mmWave sensor, hence external VBAT option is provided for the LIN VDD supply, by default 5V_IN supply is provided. To enable external VBAT supply, R32 resistor need to be mounted and R31 resistor need to be removed.

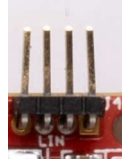

Figure 2-21. LIN Header and PHY Interface

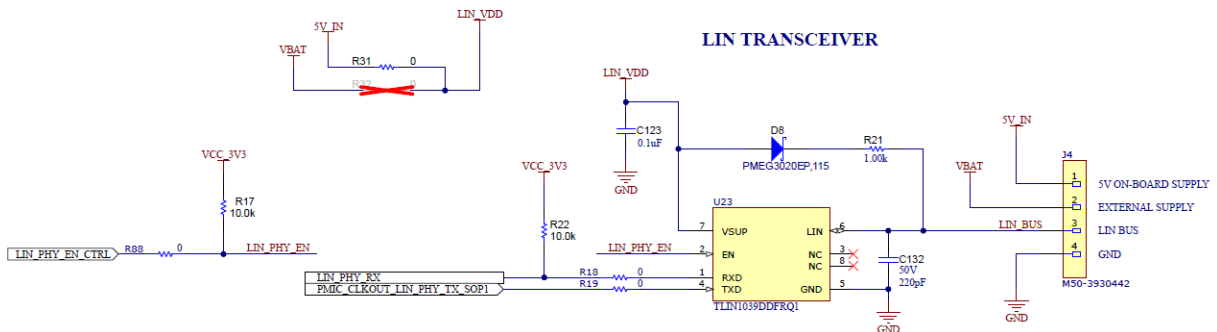

Figure 2-22. LIN PHY Interface

2.7 I2C Connections

The board features an EEPROM, current sensors, and temperature sensor for measuring on-board temperature. These are connected to the I2C bus and can be isolated using the zero Ω provided on the hardware. External I2C headers also provided for easy interface to I2C bus.

2.7.1 EEPROM

The board features an EEPROM for storing the board specific IDs (for the identification of the EVM through the XDS110 interface). Please refer to EVM schematics for the I2C addresses.

2.7.2 On-Board Sensors

The IWRL6432AOPEVM provides access to an on-board temperature sensor (TMP112AQDRLRQ1) and four on-board current sensors (INA228AIDGST). These sensors can be controlled by the radar via I2C.

The current sensors are designed to measure the current being supplied to the various power rails of the IWRL6432AOP device. For details on the supply rails that can be measured using the current sensors, refer to Table 2-4.

Table 2-4. Current Sensor Supply Details

Reference Designator	Supply Node	PCB Net Name
U6	1.8V Supply	REG_1V8
U7	3.3V Supply	VCC_3V3
U8	1.2V Supply	REG_1V2
U25	1.2V RF Supply	REG_RF_1V2

2.8 XDS110 Interface

J5 provides access to the onboard XDS110 (TM4C1294NCPDT) emulator. This connection provides the following interfaces to the PC:

- JTAG for CCS connectivity
- Application/user UART (Configuration and data communication to PC)

When used in standalone mode of operation as shown in [Figure 2-25](#), the power is supplied through a single USB connector; the same USB connector J5 is also used for configuration and data transfer through the XDS110 USB to UART converter. When enumerated correctly, the 2 UART ports from the XDS110 are displayed on the device manager as a virtual COM Port, similar to that shown in [Figure 2-24](#).

If the PC is unable to recognize the above COM ports, Then install the latest [EMUpack](#). Similar to that shown in [Figure 2-23](#).

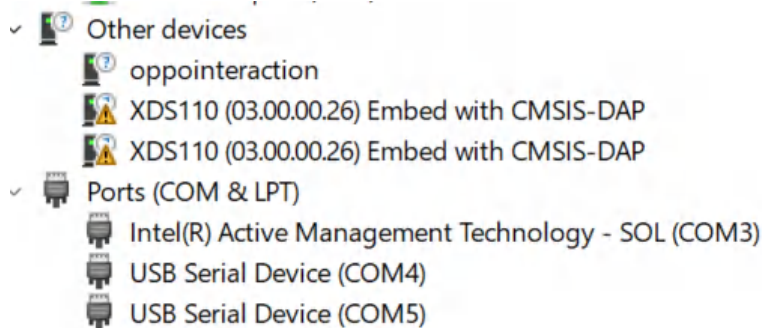

Figure 2-23. Virtual COM Port Before Installing XDS Drivers

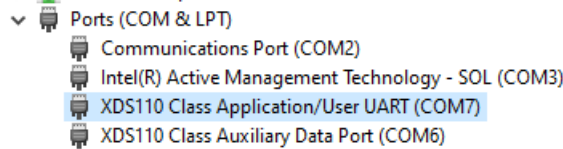

Figure 2-24. Virtual COM Port After Installing XDS Drivers

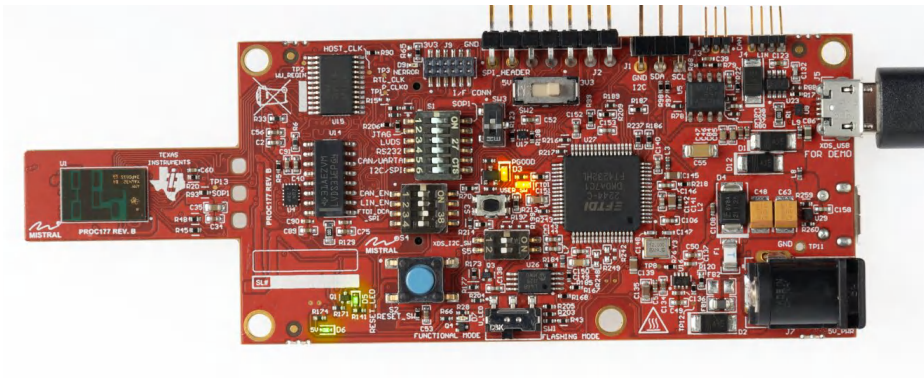

Figure 2-25. EVM in Functional Mode Using Standalone Operation

EVM uses single UART port for both device configuration and processed data communication to PC.

2.9 FTDI Interface

J10 provides access to the onboard FTDI ports. This provides the following interfaces to the PC:

- FTDI Port A -> SPI interface
- FTDI Port B-> Host INTR signal.
- FTDI Port C -> NRESET control signal.
- FTDI Port D -> SOP0, SOP1 control signals

When the USB is connected for the first time to the PC, a possibility is that Windows® does not recognize the device. This is indicated in the device manager with yellow exclamation marks, as shown in [Figure 2-26](#).

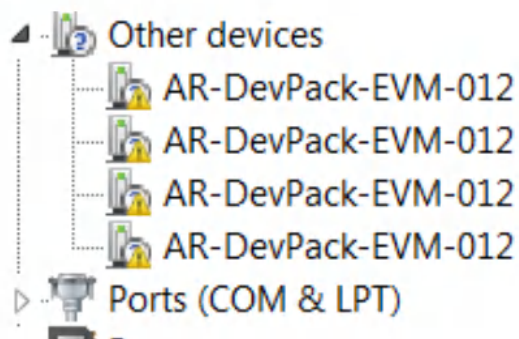

Figure 2-26. Uninstalled FTDI Drivers

To install the devices, download the latest FTDI drivers available in [Section 3.3](#). Right click on these devices, and update the drivers by pointing to the location where the FTDI drivers were installed (C:\ti\mmwave_sdk_<version_number>\tools\ftdi). This must be done for all four COM ports. When all four COM ports are installed, the device manager recognizes these devices and indicates the COM port numbers, as shown in [.Figure 2-27](#)

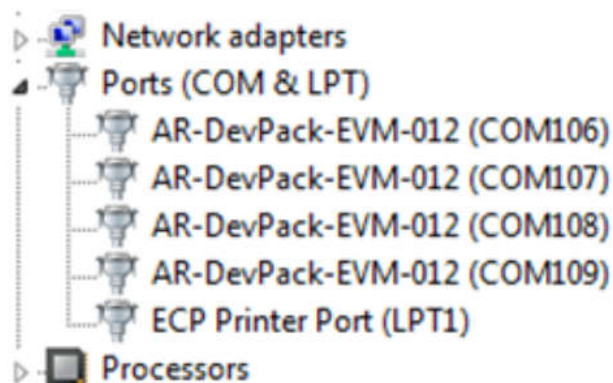

Figure 2-27. Installed FTDI Drivers

3 Software

3.1 Software Description

To enable quick development of end applications on the ARM Cortex-M4F core in the IWRL6432AOP, TI provides a software development kit (SDK) that includes demo codes, software drivers, emulation packages for debug, and more.

For more information, please refer to mmWave low power SDK user guide: [MMWAVE-L-SDK](#).

3.2 Flashing the Board

1. Make sure the drivers have been successfully installed and COM ports enumerated. Refer to [Section 2.8](#).
2. Configure the SOP to [Section 2.2.1](#).
3. Press the Reset switch ([Section 2.2.2](#)) to make sure that the board boots up in the right mode.
4. Run the mmWave Visualizer inside mmWave-L-SDK tool folder and use the flashing tab and follow the instruction or use Uniflash tool. Similar to that shown in [Figure 3-1](#).
5. Enter the application port number for the flashing interface.
6. Select the image to flash to the EVM in the *Image Flash* menu, or directly upload the image from the mmWave SDK
 (C:\ti\MMWAVE_L_SDK\examples\mmw_demo\motion_and_presence_detection\prebuilt_binaries\xwrl64xx). Load appimage to serial flash. Similar to that shown in [Figure 3-2](#). Please refer mmWave SDK for the flash binary for running out of box demos.

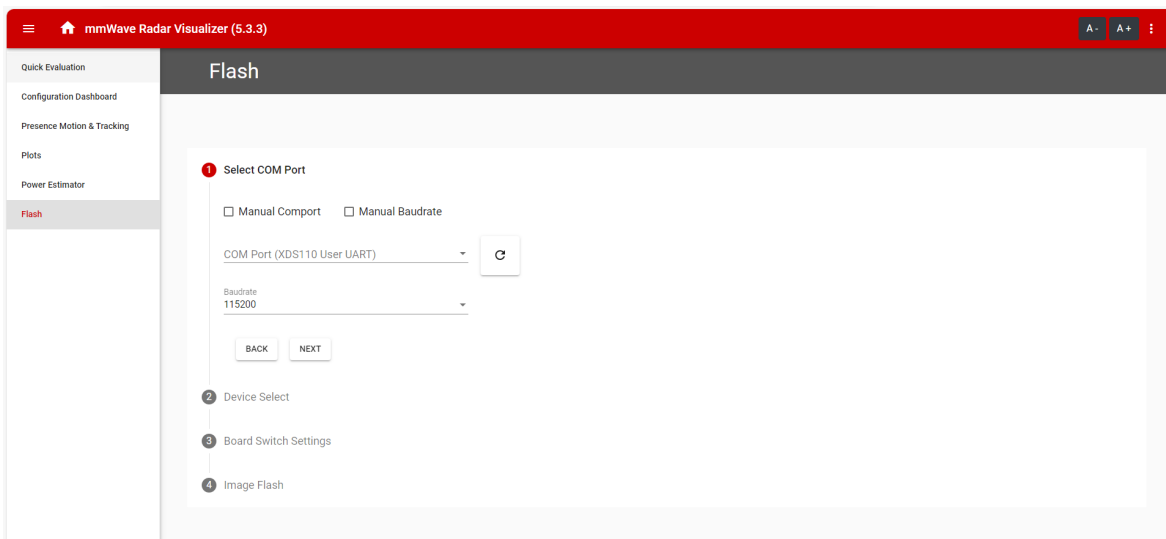

Figure 3-1. Flash Tab in Visualizer Tool

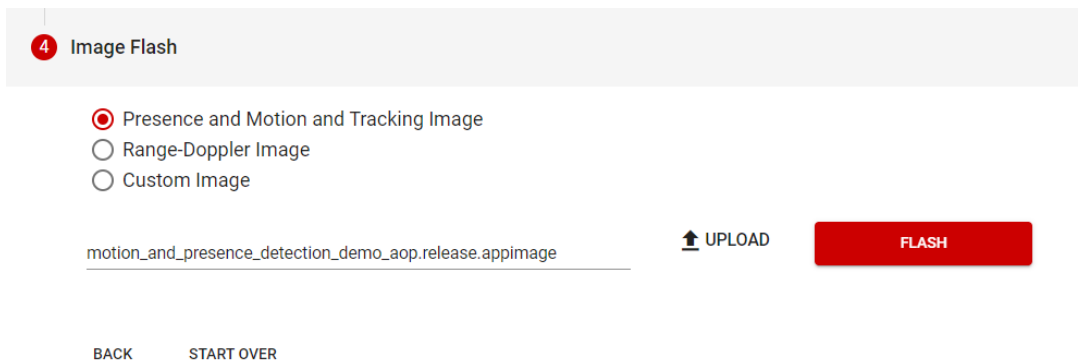

Figure 3-2. Out of Box Demo Binary App

3.3 mmWave Out of Box Demo

TI provides sample demo code to easily get started with the IWRL6432AOP evaluation module (EVM) to experience the functionality of the IWRL6432AOP mmWave sensor. For details on getting started with these demos, see [mmWave-L-SDK](#) on ti.com page.

See how to get started with IWRL6432AOP mmWave radar sensors with this step-by-step tutorial on running the out-of-box demo and visualizing the output. For more information, see [Out-of-box demo tutorial for IWRL6432AOP evaluation modules](#).

3.3.1 IWRL6432AOP Demo Visualization Getting Started

Please follow the below step by step procedure for running the OOB demo.

1. Connect the EVM to the PC via USB.
2. Open the mmWave Visualizer inside mmWave-L-SDK tool. Check the SOP settings for [Section 2.2.1](#).
3. Navigate to *Configuration Dashboard* tab of the visualizer and select the device. Wait for AUTO detection of COM ports (else press refresh). Alternatively, manually select device COM port (if not already selected). Select preset configuration under *Configuration Selection* drop-down. Similar to that shown in [Figure 3-3](#).
4. Click on *Send Config to Device*.
5. After configurations are successfully sent, the *Plots* tab displays range plot via radar point cloud information. Similar to that shown in [Figure 3-4](#).

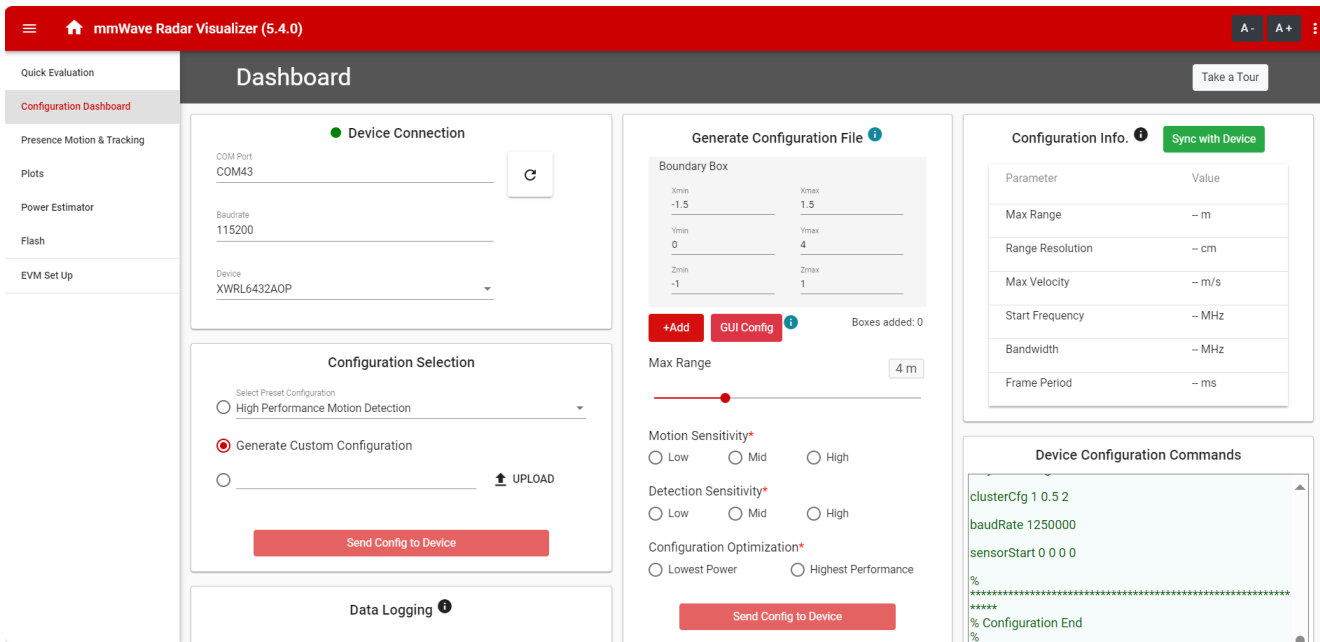

The screenshot shows the 'mmWave Radar Visualizer (5.4.0)' interface. The 'Configuration Dashboard' is active, displaying various settings for the IWRL6432AOP device. The 'Device Connection' section shows the COM Port as 'COM43' and the Device as 'XWRL6432AOP'. The 'Configuration Selection' section has 'Generate Custom Configuration' selected. The 'Generate Configuration File' section shows a boundary box with Xmin: -1.5, Xmax: 1.5, Ymin: 0, Ymax: 4, Zmin: -1, Zmax: 1, and a Max Range slider set to 4 m. The 'Configuration Info' section lists parameters like Max Range, Range Resolution, Max Velocity, Start Frequency, Bandwidth, and Frame Period. The 'Device Configuration Commands' section shows a list of commands including clusterCfg, baudRate, and sensorStart.

Figure 3-3. Configuration Dashboard

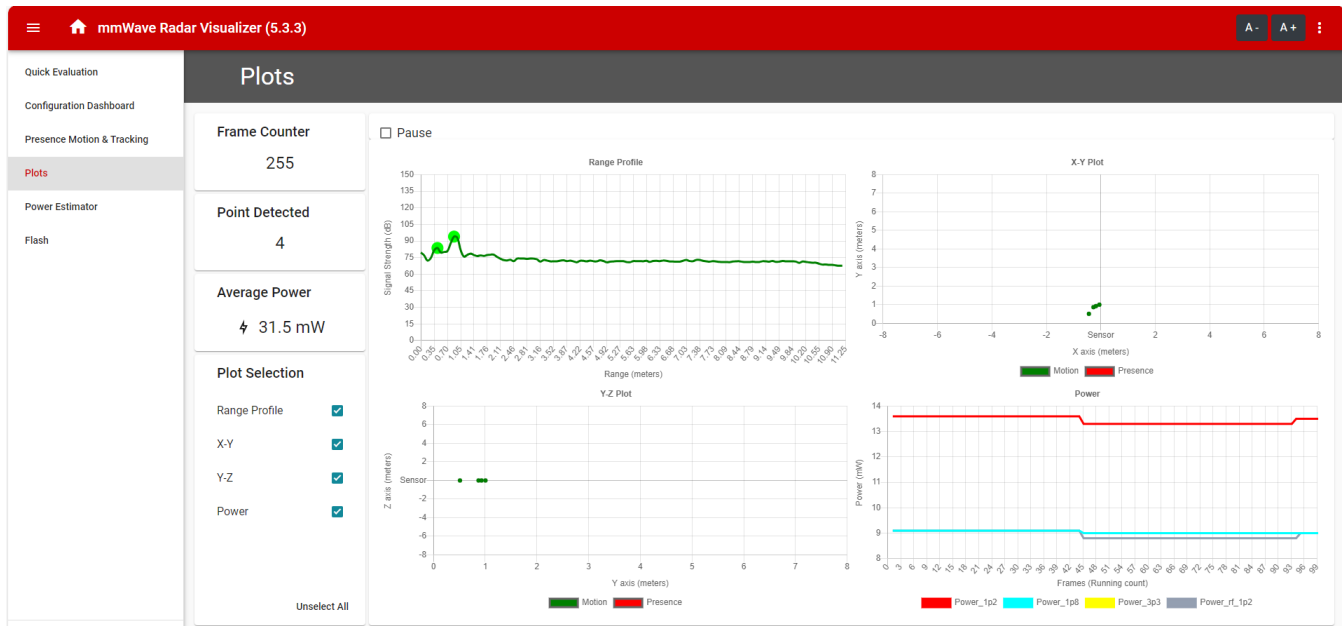

Figure 3-4. Plots Tab in Visualizer Tool

3.4 DCA1000EVM Mode

The setup for raw data capture using DCA1000EVM is shown in Figure 3-5.

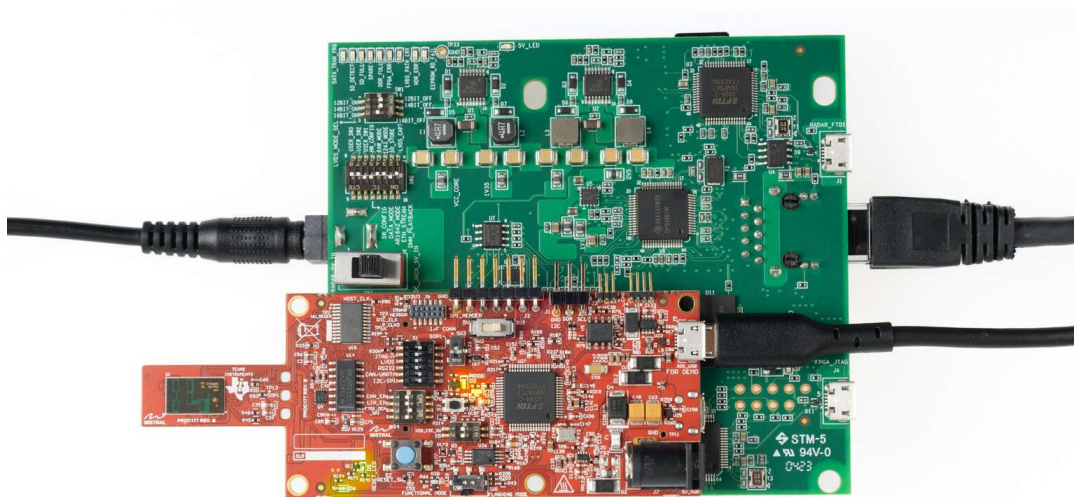

Figure 3-5. DCA1000EVM Mode (Top View)

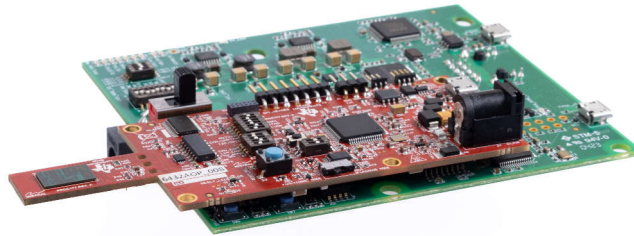

Figure 3-6. DCA1000EVM Mode (Side View)

For the switch settings for the DCA1000 raw ADC capture card, refer to [Section 2.2](#).

4 Hardware Design Files

4.1 Schematics

To view the schematics, assembly drawings, see [IWRL6432AOPEVM Schematic, Assembly Files, and BOM](#).

4.2 PCB Layouts

To view the design database and layout details, see [IWRL6432AOPEVM Database and Layout Files](#).

4.2.1 PCB Storage and Handling Recommendations:

This EVM contains components that can potentially be damaged by electrostatic discharge. Always transport and store the EVM in the supplied ESD bag when not in use. Handle using an antistatic wristband and operate on an antistatic work surface. For more information on proper handling, see [Electrostatic Discharge \(ESD\)](#).

4.2.1.1 PCB Storage and Handling Recommendations:

To avoid oxidation, the PCB must be stored in an ESD cover and kept at a controlled room temperature with low humidity conditions. All ESD precautions must be taken while using and handling the EVM.

4.2.1.2 Higher Power Demanding Applications

Most of the EVM can be operated with a single USB cable. For higher power consumption applications where a single USB-port cannot supply power needed, use an external 5V/2A or higher power adapter.

4.3 Bill of Materials (BOM)

To view the Bill of Materials (BOM), see [IWRL6432AOPEVM Schematic, Assembly Files, and BOM](#).

5 Additional Information

5.1 Trademarks

ARM® and Cortex® are registered trademarks of Arm Limited.

Windows® is a registered trademark of Microsoft.

All trademarks are the property of their respective owners.

6 Related Documentation

1. Texas Instruments, [IWRL6432BOOST/AWRL6432BOOST EVM: FR4-Based Low Power 60GHz mm-Wave Sensor EVM User Guide](#)
2. Texas Instruments, [IWRL6432AOP Single-Chip 57 to 64GHz Industrial Radar Sensor with Antenna On Package \(AOP\), data sheet](#)
3. Texas Instruments, [IWRL6432AOP Device Silicon Errata](#)

7 TI E2E Community

Search the forums at e2e.ti.com. If users cannot find the answer, then post the question to the community.

8 References

1. Texas Instruments, [DCA1000EVM Data Capture Card User's Guide](#)
2. Texas Instruments, [MMWAVE-L-SDK](#)

9 Revision History

NOTE: Page numbers for previous revisions may differ from page numbers in the current version.

Changes from January 1, 2025 to July 9, 2025 (from Revision A (January 2025) to Revision B (July 2025))

	Page
• Updated maximum frequency to 63.5GHz in <i>Specification</i> section.....	2
• Updated maximum frequency to 63.5GHz in <i>Device Information</i> section.....	4

STANDARD TERMS FOR EVALUATION MODULES

1. *Delivery:* TI delivers TI evaluation boards, kits, or modules, including any accompanying demonstration software, components, and/or documentation which may be provided together or separately (collectively, an "EVM" or "EVMs") to the User ("User") in accordance with the terms set forth herein. User's acceptance of the EVM is expressly subject to the following terms.
 - 1.1 EVMs are intended solely for product or software developers for use in a research and development setting to facilitate feasibility evaluation, experimentation, or scientific analysis of TI semiconductors products. EVMs have no direct function and are not finished products. EVMs shall not be directly or indirectly assembled as a part or subassembly in any finished product. For clarification, any software or software tools provided with the EVM ("Software") shall not be subject to the terms and conditions set forth herein but rather shall be subject to the applicable terms that accompany such Software
 - 1.2 EVMs are not intended for consumer or household use. EVMs may not be sold, sublicensed, leased, rented, loaned, assigned, or otherwise distributed for commercial purposes by Users, in whole or in part, or used in any finished product or production system.
2. *Limited Warranty and Related Remedies/Disclaimers:*
 - 2.1 These terms do not apply to Software. The warranty, if any, for Software is covered in the applicable Software License Agreement.
 - 2.2 TI warrants that the TI EVM will conform to TI's published specifications for ninety (90) days after the date TI delivers such EVM to User. Notwithstanding the foregoing, TI shall not be liable for a nonconforming EVM if (a) the nonconformity was caused by neglect, misuse or mistreatment by an entity other than TI, including improper installation or testing, or for any EVMs that have been altered or modified in any way by an entity other than TI, (b) the nonconformity resulted from User's design, specifications or instructions for such EVMs or improper system design, or (c) User has not paid on time. Testing and other quality control techniques are used to the extent TI deems necessary. TI does not test all parameters of each EVM. User's claims against TI under this Section 2 are void if User fails to notify TI of any apparent defects in the EVMs within ten (10) business days after delivery, or of any hidden defects with ten (10) business days after the defect has been detected.
 - 2.3 TI's sole liability shall be at its option to repair or replace EVMs that fail to conform to the warranty set forth above, or credit User's account for such EVM. TI's liability under this warranty shall be limited to EVMs that are returned during the warranty period to the address designated by TI and that are determined by TI not to conform to such warranty. If TI elects to repair or replace such EVM, TI shall have a reasonable time to repair such EVM or provide replacements. Repaired EVMs shall be warranted for the remainder of the original warranty period. Replaced EVMs shall be warranted for a new full ninety (90) day warranty period.

WARNING

Evaluation Kits are intended solely for use by technically qualified, professional electronics experts who are familiar with the dangers and application risks associated with handling electrical mechanical components, systems, and subsystems.

User shall operate the Evaluation Kit within TI's recommended guidelines and any applicable legal or environmental requirements as well as reasonable and customary safeguards. Failure to set up and/or operate the Evaluation Kit within TI's recommended guidelines may result in personal injury or death or property damage. Proper set up entails following TI's instructions for electrical ratings of interface circuits such as input, output and electrical loads.

NOTE:

EXPOSURE TO ELECTROSTATIC DISCHARGE (ESD) MAY CAUSE DEGRADATION OR FAILURE OF THE EVALUATION KIT; TI RECOMMENDS STORAGE OF THE EVALUATION KIT IN A PROTECTIVE ESD BAG.

3 Regulatory Notices:

3.1 United States

3.1.1 Notice applicable to EVMs not FCC-Approved:

FCC NOTICE: This kit is designed to allow product developers to evaluate electronic components, circuitry, or software associated with the kit to determine whether to incorporate such items in a finished product and software developers to write software applications for use with the end product. This kit is not a finished product and when assembled may not be resold or otherwise marketed unless all required FCC equipment authorizations are first obtained. Operation is subject to the condition that this product not cause harmful interference to licensed radio stations and that this product accept harmful interference. Unless the assembled kit is designed to operate under part 15, part 18 or part 95 of this chapter, the operator of the kit must operate under the authority of an FCC license holder or must secure an experimental authorization under part 5 of this chapter.

3.1.2 For EVMs annotated as FCC – FEDERAL COMMUNICATIONS COMMISSION Part 15 Compliant:

CAUTION

This device complies with part 15 of the FCC Rules. Operation is subject to the following two conditions: (1) This device may not cause harmful interference, and (2) this device must accept any interference received, including interference that may cause undesired operation.

Changes or modifications not expressly approved by the party responsible for compliance could void the user's authority to operate the equipment.

FCC Interference Statement for Class A EVM devices

NOTE: This equipment has been tested and found to comply with the limits for a Class A digital device, pursuant to part 15 of the FCC Rules. These limits are designed to provide reasonable protection against harmful interference when the equipment is operated in a commercial environment. This equipment generates, uses, and can radiate radio frequency energy and, if not installed and used in accordance with the instruction manual, may cause harmful interference to radio communications. Operation of this equipment in a residential area is likely to cause harmful interference in which case the user will be required to correct the interference at his own expense.

FCC Interference Statement for Class B EVM devices

NOTE: This equipment has been tested and found to comply with the limits for a Class B digital device, pursuant to part 15 of the FCC Rules. These limits are designed to provide reasonable protection against harmful interference in a residential installation. This equipment generates, uses and can radiate radio frequency energy and, if not installed and used in accordance with the instructions, may cause harmful interference to radio communications. However, there is no guarantee that interference will not occur in a particular installation. If this equipment does cause harmful interference to radio or television reception, which can be determined by turning the equipment off and on, the user is encouraged to try to correct the interference by one or more of the following measures:

- Reorient or relocate the receiving antenna.
- Increase the separation between the equipment and receiver.
- Connect the equipment into an outlet on a circuit different from that to which the receiver is connected.
- Consult the dealer or an experienced radio/TV technician for help.

3.2 Canada

3.2.1 For EVMs issued with an Industry Canada Certificate of Conformance to RSS-210 or RSS-247

Concerning EVMs Including Radio Transmitters:

This device complies with Industry Canada license-exempt RSSs. Operation is subject to the following two conditions:

(1) this device may not cause interference, and (2) this device must accept any interference, including interference that may cause undesired operation of the device.

Concernant les EVMs avec appareils radio:

Le présent appareil est conforme aux CNR d'Industrie Canada applicables aux appareils radio exempts de licence. L'exploitation est autorisée aux deux conditions suivantes: (1) l'appareil ne doit pas produire de brouillage, et (2) l'utilisateur de l'appareil doit accepter tout brouillage radioélectrique subi, même si le brouillage est susceptible d'en compromettre le fonctionnement.

Concerning EVMs Including Detachable Antennas:

Under Industry Canada regulations, this radio transmitter may only operate using an antenna of a type and maximum (or lesser) gain approved for the transmitter by Industry Canada. To reduce potential radio interference to other users, the antenna type and its gain should be so chosen that the equivalent isotropically radiated power (e.i.r.p.) is not more than that necessary for successful communication. This radio transmitter has been approved by Industry Canada to operate with the antenna types listed in the user guide with the maximum permissible gain and required antenna impedance for each antenna type indicated. Antenna types not included in this list, having a gain greater than the maximum gain indicated for that type, are strictly prohibited for use with this device.

Concernant les EVMs avec antennes détachables

Conformément à la réglementation d'Industrie Canada, le présent émetteur radio peut fonctionner avec une antenne d'un type et d'un gain maximal (ou inférieur) approuvé pour l'émetteur par Industrie Canada. Dans le but de réduire les risques de brouillage radioélectrique à l'intention des autres utilisateurs, il faut choisir le type d'antenne et son gain de sorte que la puissance isotrope rayonnée équivalente (p.i.r.e.) ne dépasse pas l'intensité nécessaire à l'établissement d'une communication satisfaisante. Le présent émetteur radio a été approuvé par Industrie Canada pour fonctionner avec les types d'antenne énumérés dans le manuel d'usage et ayant un gain admissible maximal et l'impédance requise pour chaque type d'antenne. Les types d'antenne non inclus dans cette liste, ou dont le gain est supérieur au gain maximal indiqué, sont strictement interdits pour l'exploitation de l'émetteur.

3.3 Japan

3.3.1 *Notice for EVMs delivered in Japan:* Please see http://www.tij.co.jp/lstds/ti_ja/general/eStore/notice_01.page 日本国内に輸入される評価用キット、ボードについては、次のところをご覧ください。

<https://www.ti.com/ja-jp/legal/notice-for-evaluation-kits-delivered-in-japan.html>

3.3.2 *Notice for Users of EVMs Considered "Radio Frequency Products" in Japan:* EVMs entering Japan may not be certified by TI as conforming to Technical Regulations of Radio Law of Japan.

If User uses EVMs in Japan, not certified to Technical Regulations of Radio Law of Japan, User is required to follow the instructions set forth by Radio Law of Japan, which includes, but is not limited to, the instructions below with respect to EVMs (which for the avoidance of doubt are stated strictly for convenience and should be verified by User):

1. Use EVMs in a shielded room or any other test facility as defined in the notification #173 issued by Ministry of Internal Affairs and Communications on March 28, 2006, based on Sub-section 1.1 of Article 6 of the Ministry's Rule for Enforcement of Radio Law of Japan,
2. Use EVMs only after User obtains the license of Test Radio Station as provided in Radio Law of Japan with respect to EVMs, or
3. Use of EVMs only after User obtains the Technical Regulations Conformity Certification as provided in Radio Law of Japan with respect to EVMs. Also, do not transfer EVMs, unless User gives the same notice above to the transferee. Please note that if User does not follow the instructions above, User will be subject to penalties of Radio Law of Japan.

【無線電波を送信する製品の開発キットをお使いになる際の注意事項】 開発キットの中には技術基準適合証明を受けていないものがあります。技術適合証明を受けていないものご使用に際しては、電波法遵守のため、以下のいずれかの措置を取っていただく必要がありますのでご注意ください。

1. 電波法施行規則第6条第1項第1号に基づく平成18年3月28日総務省告示第173号で定められた電波暗室等の試験設備でご使用いただく。
2. 実験局の免許を取得後ご使用いただく。
3. 技術基準適合証明を取得後ご使用いただく。

なお、本製品は、上記の「ご使用にあたっての注意」を譲渡先、移転先に通知しない限り、譲渡、移転できないものとします。

上記を遵守頂けない場合は、電波法の罰則が適用される可能性があることをご留意ください。日本テキサス・イ

ンスツルメンツ株式会社

東京都新宿区西新宿 6 丁目 2 4 番 1 号

西新宿三井ビル

3.3.3 *Notice for EVMs for Power Line Communication:* Please see http://www.tij.co.jp/lstds/ti_ja/general/eStore/notice_02.page

電力線搬送波通信についての開発キットをお使いになる際の注意事項については、次のところをご覧ください。 <https://www.ti.com/ja-jp/legal/notice-for-evaluation-kits-for-power-line-communication.html>

3.4 European Union

3.4.1 *For EVMs subject to EU Directive 2014/30/EU (Electromagnetic Compatibility Directive):*

This is a class A product intended for use in environments other than domestic environments that are connected to a low-voltage power-supply network that supplies buildings used for domestic purposes. In a domestic environment this product may cause radio interference in which case the user may be required to take adequate measures.

-
- 4 *EVM Use Restrictions and Warnings:*
 - 4.1 EVMS ARE NOT FOR USE IN FUNCTIONAL SAFETY AND/OR SAFETY CRITICAL EVALUATIONS, INCLUDING BUT NOT LIMITED TO EVALUATIONS OF LIFE SUPPORT APPLICATIONS.
 - 4.2 User must read and apply the user guide and other available documentation provided by TI regarding the EVM prior to handling or using the EVM, including without limitation any warning or restriction notices. The notices contain important safety information related to, for example, temperatures and voltages.
 - 4.3 *Safety-Related Warnings and Restrictions:*
 - 4.3.1 User shall operate the EVM within TI's recommended specifications and environmental considerations stated in the user guide, other available documentation provided by TI, and any other applicable requirements and employ reasonable and customary safeguards. Exceeding the specified performance ratings and specifications (including but not limited to input and output voltage, current, power, and environmental ranges) for the EVM may cause personal injury or death, or property damage. If there are questions concerning performance ratings and specifications, User should contact a TI field representative prior to connecting interface electronics including input power and intended loads. Any loads applied outside of the specified output range may also result in unintended and/or inaccurate operation and/or possible permanent damage to the EVM and/or interface electronics. Please consult the EVM user guide prior to connecting any load to the EVM output. If there is uncertainty as to the load specification, please contact a TI field representative. During normal operation, even with the inputs and outputs kept within the specified allowable ranges, some circuit components may have elevated case temperatures. These components include but are not limited to linear regulators, switching transistors, pass transistors, current sense resistors, and heat sinks, which can be identified using the information in the associated documentation. When working with the EVM, please be aware that the EVM may become very warm.
 - 4.3.2 EVMs are intended solely for use by technically qualified, professional electronics experts who are familiar with the dangers and application risks associated with handling electrical mechanical components, systems, and subsystems. User assumes all responsibility and liability for proper and safe handling and use of the EVM by User or its employees, affiliates, contractors or designees. User assumes all responsibility and liability to ensure that any interfaces (electronic and/or mechanical) between the EVM and any human body are designed with suitable isolation and means to safely limit accessible leakage currents to minimize the risk of electrical shock hazard. User assumes all responsibility and liability for any improper or unsafe handling or use of the EVM by User or its employees, affiliates, contractors or designees.
 - 4.4 User assumes all responsibility and liability to determine whether the EVM is subject to any applicable international, federal, state, or local laws and regulations related to User's handling and use of the EVM and, if applicable, User assumes all responsibility and liability for compliance in all respects with such laws and regulations. User assumes all responsibility and liability for proper disposal and recycling of the EVM consistent with all applicable international, federal, state, and local requirements.
 5. *Accuracy of Information:* To the extent TI provides information on the availability and function of EVMs, TI attempts to be as accurate as possible. However, TI does not warrant the accuracy of EVM descriptions, EVM availability or other information on its websites as accurate, complete, reliable, current, or error-free.
 6. *Disclaimers:*
 - 6.1 EXCEPT AS SET FORTH ABOVE, EVMS AND ANY MATERIALS PROVIDED WITH THE EVM (INCLUDING, BUT NOT LIMITED TO, REFERENCE DESIGNS AND THE DESIGN OF THE EVM ITSELF) ARE PROVIDED "AS IS" AND "WITH ALL FAULTS." TI DISCLAIMS ALL OTHER WARRANTIES, EXPRESS OR IMPLIED, REGARDING SUCH ITEMS, INCLUDING BUT NOT LIMITED TO ANY EPIDEMIC FAILURE WARRANTY OR IMPLIED WARRANTIES OF MERCHANTABILITY OR FITNESS FOR A PARTICULAR PURPOSE OR NON-INFRINGEMENT OF ANY THIRD PARTY PATENTS, COPYRIGHTS, TRADE SECRETS OR OTHER INTELLECTUAL PROPERTY RIGHTS.
 - 6.2 EXCEPT FOR THE LIMITED RIGHT TO USE THE EVM SET FORTH HEREIN, NOTHING IN THESE TERMS SHALL BE CONSTRUED AS GRANTING OR CONFERRING ANY RIGHTS BY LICENSE, PATENT, OR ANY OTHER INDUSTRIAL OR INTELLECTUAL PROPERTY RIGHT OF TI, ITS SUPPLIERS/LICENSORS OR ANY OTHER THIRD PARTY, TO USE THE EVM IN ANY FINISHED END-USER OR READY-TO-USE FINAL PRODUCT, OR FOR ANY INVENTION, DISCOVERY OR IMPROVEMENT, REGARDLESS OF WHEN MADE, CONCEIVED OR ACQUIRED.
 7. *USER'S INDEMNITY OBLIGATIONS AND REPRESENTATIONS.* USER WILL DEFEND, INDEMNIFY AND HOLD TI, ITS LICENSORS AND THEIR REPRESENTATIVES HARMLESS FROM AND AGAINST ANY AND ALL CLAIMS, DAMAGES, LOSSES, EXPENSES, COSTS AND LIABILITIES (COLLECTIVELY, "CLAIMS") ARISING OUT OF OR IN CONNECTION WITH ANY HANDLING OR USE OF THE EVM THAT IS NOT IN ACCORDANCE WITH THESE TERMS. THIS OBLIGATION SHALL APPLY WHETHER CLAIMS ARISE UNDER STATUTE, REGULATION, OR THE LAW OF TORT, CONTRACT OR ANY OTHER LEGAL THEORY, AND EVEN IF THE EVM FAILS TO PERFORM AS DESCRIBED OR EXPECTED.

8. *Limitations on Damages and Liability:*

8.1 *General Limitations.* IN NO EVENT SHALL TI BE LIABLE FOR ANY SPECIAL, COLLATERAL, INDIRECT, PUNITIVE, INCIDENTAL, CONSEQUENTIAL, OR EXEMPLARY DAMAGES IN CONNECTION WITH OR ARISING OUT OF THESE TERMS OR THE USE OF THE EVMS , REGARDLESS OF WHETHER TI HAS BEEN ADVISED OF THE POSSIBILITY OF SUCH DAMAGES. EXCLUDED DAMAGES INCLUDE, BUT ARE NOT LIMITED TO, COST OF REMOVAL OR REINSTALLATION, ANCILLARY COSTS TO THE PROCUREMENT OF SUBSTITUTE GOODS OR SERVICES, RETESTING, OUTSIDE COMPUTER TIME, LABOR COSTS, LOSS OF GOODWILL, LOSS OF PROFITS, LOSS OF SAVINGS, LOSS OF USE, LOSS OF DATA, OR BUSINESS INTERRUPTION. NO CLAIM, SUIT OR ACTION SHALL BE BROUGHT AGAINST TI MORE THAN TWELVE (12) MONTHS AFTER THE EVENT THAT GAVE RISE TO THE CAUSE OF ACTION HAS OCCURRED.

8.2 *Specific Limitations.* IN NO EVENT SHALL TI'S AGGREGATE LIABILITY FROM ANY USE OF AN EVM PROVIDED HEREUNDER, INCLUDING FROM ANY WARRANTY, INDEMNITY OR OTHER OBLIGATION ARISING OUT OF OR IN CONNECTION WITH THESE TERMS, , EXCEED THE TOTAL AMOUNT PAID TO TI BY USER FOR THE PARTICULAR EVM(S) AT ISSUE DURING THE PRIOR TWELVE (12) MONTHS WITH RESPECT TO WHICH LOSSES OR DAMAGES ARE CLAIMED. THE EXISTENCE OF MORE THAN ONE CLAIM SHALL NOT ENLARGE OR EXTEND THIS LIMIT.

9. *Return Policy.* Except as otherwise provided, TI does not offer any refunds, returns, or exchanges. Furthermore, no return of EVM(s) will be accepted if the package has been opened and no return of the EVM(s) will be accepted if they are damaged or otherwise not in a resalable condition. If User feels it has been incorrectly charged for the EVM(s) it ordered or that delivery violates the applicable order, User should contact TI. All refunds will be made in full within thirty (30) working days from the return of the components(s), excluding any postage or packaging costs.

10. *Governing Law:* These terms and conditions shall be governed by and interpreted in accordance with the laws of the State of Texas, without reference to conflict-of-laws principles. User agrees that non-exclusive jurisdiction for any dispute arising out of or relating to these terms and conditions lies within courts located in the State of Texas and consents to venue in Dallas County, Texas. Notwithstanding the foregoing, any judgment may be enforced in any United States or foreign court, and TI may seek injunctive relief in any United States or foreign court.

Mailing Address: Texas Instruments, Post Office Box 655303, Dallas, Texas 75265
Copyright © 2023, Texas Instruments Incorporated

IMPORTANT NOTICE AND DISCLAIMER

TI PROVIDES TECHNICAL AND RELIABILITY DATA (INCLUDING DATASHEETS), DESIGN RESOURCES (INCLUDING REFERENCE DESIGNS), APPLICATION OR OTHER DESIGN ADVICE, WEB TOOLS, SAFETY INFORMATION, AND OTHER RESOURCES "AS IS" AND WITH ALL FAULTS, AND DISCLAIMS ALL WARRANTIES, EXPRESS AND IMPLIED, INCLUDING WITHOUT LIMITATION ANY IMPLIED WARRANTIES OF MERCHANTABILITY, FITNESS FOR A PARTICULAR PURPOSE OR NON-INFRINGEMENT OF THIRD PARTY INTELLECTUAL PROPERTY RIGHTS.

These resources are intended for skilled developers designing with TI products. You are solely responsible for (1) selecting the appropriate TI products for your application, (2) designing, validating and testing your application, and (3) ensuring your application meets applicable standards, and any other safety, security, regulatory or other requirements.

These resources are subject to change without notice. TI grants you permission to use these resources only for development of an application that uses the TI products described in the resource. Other reproduction and display of these resources is prohibited. No license is granted to any other TI intellectual property right or to any third party intellectual property right. TI disclaims responsibility for, and you fully indemnify TI and its representatives against any claims, damages, costs, losses, and liabilities arising out of your use of these resources.

TI's products are provided subject to [TI's Terms of Sale](#), [TI's General Quality Guidelines](#), or other applicable terms available either on ti.com or provided in conjunction with such TI products. TI's provision of these resources does not expand or otherwise alter TI's applicable warranties or warranty disclaimers for TI products. Unless TI explicitly designates a product as custom or customer-specified, TI products are standard, catalog, general purpose devices.

TI objects to and rejects any additional or different terms you may propose.

Copyright © 2025, Texas Instruments Incorporated

Last updated 10/2025