

TPS5516x-Q1 36-V, 1-A Output, 2-MHz, Single Inductor, Synchronous Step-Up and Step-Down Voltage Regulator

1 Features

- Qualified for automotive applications
- AEC-Q100 qualified with the following results:
 - Device temperature grade 1: -40°C to $+125^{\circ}\text{C}$ ambient operating temperature
 - Device HBM ESD classification level 2
 - Device CDM ESD classification level C4B
- **Functional Safety-Capable**
 - [Documentation available to aid functional safety system design](#)
- 2-V to 36-V input voltage range for $V_{\text{OUT}} = 5\text{ V}$
- 5-V or 12-V fixed output voltage (TPS55165-Q1)
- Adjustable output voltage options from 5.7 V to 9 V (TPS55160-Q1 and TPS55162-Q1)
- Up to 85% efficiency
- 1-A output current for $V_{\text{OUT}} = 5\text{ V}$ and $V_{\text{IN}} \geq 5.3\text{ V}$
- 0.8-A output current for $V_{\text{OUT}} = 5\text{ V}$ and $V_{\text{IN}} \geq 3.8\text{ V}$
- 0.4-A output current for $V_{\text{OUT}} = 5\text{ V}$ and $V_{\text{IN}} \geq 2.3\text{ V}$
- Automatic transition between step-down and step-up mode
- Low-power mode for improved efficiency at light load conditions (TPS55160-Q1/TPS55165-Q1)
- Device quiescent current less than $15\text{ }\mu\text{A}$ in low-power mode (TPS55160-Q1/TPS55165-Q1)
- Device shutdown current less than $3\text{ }\mu\text{A}$
- Forced fixed-frequency operation at 2 MHz
- Selectable spread spectrum (TPS55160-Q1 and TPS55165-Q1)
- Wake-up through IGN with power-latch function
- Smart power-good output with configurable delay time
- Overtemperature protection and output overvoltage protection
- Available in easy-to-use 20-Pin HTSSOP PowerPAD™ package

2 Applications

- Start-stop sensitive automotive power applications
 - [Infotainment and cluster](#)
 - [Body electronics and gateway modules](#)
- Industrial applications with fluctuating input voltage
 - Solar-to-battery charging
 - Li-ion battery packs

3 Description

The TPS5516x-Q1 family of devices is a high-voltage synchronous buck-boost DC-DC converter. The device provides a stable power-supply output from a wide varying input-power supply such as an automotive car battery. The buck-boost overlap control ensures automatic transition between step-down and step-up mode with optimal efficiency. The TPS55165-Q1 output voltage can be set to a fixed level of 5 V or 12 V. The TPS55160-Q1 and TPS55162-Q1 devices have a configurable output voltage ranging from 5.7 V to 9 V that is set by an external resistive divider.

Output currents can be as high as 1 A for a normal car battery voltage, and can be maintained at 0.4 A for lower input voltages, such as those for common battery-cranking profiles. The buck-boost converter is based on a fixed-frequency, pulse-width-modulation (PWM) control circuit using synchronous rectification to obtain maximum efficiency. The switching frequency is set to 2 MHz (typical) which allows for the usage of a small inductor that uses less board space.

Device Information

PART NUMBER	PACKAGE ⁽¹⁾	BODY SIZE (NOM)
TPS55160-Q1	HTSSOP (20)	6.50 mm × 4.40 mm
TPS55162-Q1		
TPS55165-Q1		

(1) For all available packages, see the orderable addendum at the end of the data sheet.

Simplified Schematic

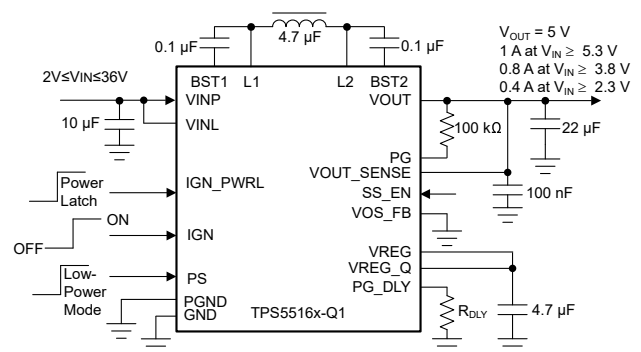

Table of Contents

1 Features	1	7.17 Switching Characteristics — IGN Wakeup.....	11
2 Applications	1	7.18 Switching Characteristics — Logic Pins PS, IGN_PWRL, SS_EN.....	11
3 Description	1	7.19 Switching Characteristics – Power Good.....	12
4 Revision History	2	7.20 Typical Characteristics.....	13
5 Description (continued)	3	8 Detailed Description	16
6 Pin Configuration and Functions	3	8.1 Overview.....	16
7 Specifications	5	8.2 Functional Block Diagram.....	17
7.1 Absolute Maximum Ratings.....	5	8.3 Feature Description.....	18
7.2 ESD Ratings.....	5	8.4 Device Functional Modes.....	19
7.3 Recommended Operating Conditions.....	5	9 Application and Implementation	28
7.4 Thermal Information.....	6	9.1 Application Information.....	28
7.5 Electrical Characteristics — External Components.....	6	9.2 Typical Application.....	32
7.6 Electrical Characteristics — Supply Voltage (VINP, VINL pins).....	6	10 Power Supply Recommendations	36
7.7 Electrical Characteristics — Reference Voltage (VOS_FB Pin) and Output Voltage (VOUT Pin).....	7	11 Layout	37
7.8 Electrical Characteristics — Buck-Boost.....	8	11.1 Layout Guidelines.....	37
7.9 Electrical Characteristics — Undervoltage and Overvoltage Lockout.....	9	11.2 Layout Example.....	38
7.10 Electrical Characteristics — IGN Wakeup.....	9	12 Device and Documentation Support	39
7.11 Electrical Characteristics — Logic Pins PS, IGN_PWRL, SS_EN.....	9	12.1 Device Support.....	39
7.12 Electrical Characteristics – Overtemperature Protection.....	10	12.2 Documentation Support.....	39
7.13 Electrical Characteristics – Power Good.....	10	12.3 Receiving Notification of Documentation Updates.....	39
7.14 Switching Characteristics — Reference Voltage (VOS_FB Pin) and Output Voltage (VOUT Pin).....	10	12.4 Support Resources.....	39
7.15 Switching Characteristics — Buck-Boost.....	11	12.5 Trademarks.....	39
7.16 Switching Characteristics — Undervoltage and Overvoltage Lockout.....	11	12.6 Electrostatic Discharge Caution.....	39
		12.7 Glossary.....	39
		13 Mechanical, Packaging, and Orderable Information	39

4 Revision History

NOTE: Page numbers for previous revisions may differ from page numbers in the current version.

Changes from Revision * (November 2017) to Revision A (December 2021)	Page
• Added functional safety bullet.....	1
• Updated the numbering format for tables, figures and cross-references throughout the document.	1
• Changed schematics to show correct Off-On waveform alignments with device pins	1
• Removed preview note	1
• Updated <i>Overcurrent Protection</i> section.....	18
• Changed Equation 5 solution from "0.458 A" to "0.229 A".....	33

5 Description (continued)

A selectable spread-spectrum option (TPS55160-Q1 and TPS55165-Q1) helps reduce radiated electromagnetic interference (EMI). Internal loop compensation eliminates the need for external compensation components. In low-power mode (TPS55160-Q1 and TPS55165-Q1), the device achieves a quiescent current of less than 15 μA which allows an automotive electronic control unit (ECU) to stay in standby mode (for example, listen-to-CAN mode) while achieving OEM quiescent-current requirements. The low-power mode can be disabled which forces the converter to operate in full continuous mode at a fixed switching frequency of 2 MHz (typical) for the entire load-current range. The maximum average current in the inductor is limited to a typical value of 2 A.

The converter can be disabled to minimize battery drain. Furthermore, the device offers a power-good (PG) pin to indicate when the output rail is less than the specified tolerance. The device also has a power-latch function to allow an external microcontroller unit (MCU) to keep the output voltage available for as long as needed.

The device is available in a 20-pin HTSSOP PowerPAD package.

6 Pin Configuration and Functions

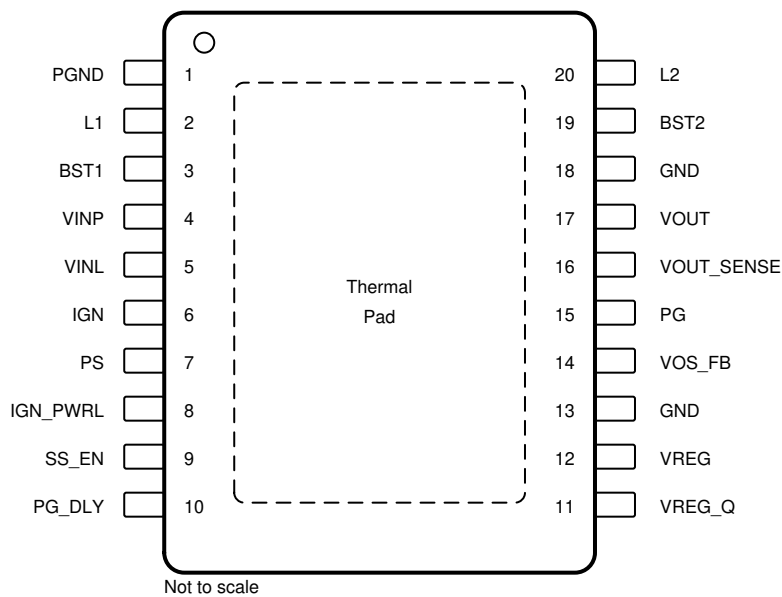

Figure 6-1. PWP PowerPAD™ Package 20-Pin HTSSOP With Exposed Thermal Pad Top View

Table 6-1. Pin Functions

PIN		I/O ⁽¹⁾	TYPE ⁽²⁾	DESCRIPTION
NAME	NO.			
PGND	1	—	G	Power-ground pin
L1	2	I	A	Buck power-stage switch node. Connect an inductor with a nominal value of 4.7 μH between the L1 and L2 pins.
BST1	3	I	A	Bootstrap node for the buck power stage. Connect a 100-nF capacitor between this pin and the L1 pin.
VINP	4	—	P	Supply-power input voltage. Connect this pin to the input supply line.
VINL	5	—	P	Supply-input voltage for internal biasing. Connect this pin to the input supply line.
IGN	6	I	D	Ignition-enable input signal. The ignition is enabled when this pin is high (1) and is disabled when this pin is low (0).
PS	7	I	D	Logic-level input signal to enable and disable low-power mode. The power mode is low-power mode when this pin is high (1) and is normal mode when this pin is low (1).
IGN_PWRL	8	I	D	Logic-level IGN power-latch signal. The IGN pin is latched when this pin is high (1) and is not latched when this pin is low (0).
SS_EN	9	I	D	Configuration pin to enable and disable the spread-Spectrum. The spread-spectrum feature is enabled when this pin is open and disabled when this pin is low.

Table 6-1. Pin Functions (continued)

PIN		I/O ⁽¹⁾	TYPE ⁽²⁾	DESCRIPTION
NAME	NO.			
PG_DLY	10	I	A	Configuration pin for power-good delay time. Connect this pin to a resistor with a value from 10kΩ to 100kΩ to configure the PG delay time from 0.5 ms to 40 ms. Connect this pin to ground for the default PG delay time which is 2 ms (typical).
VREG_Q ⁽³⁾	11	I	A	Quiet feedback pin for the gate-drive supply of the buck-boost power stages. This pin must be connected close to the top side of the 4.7-μF (typical) decoupling capacitor at the VREG output pin.
VREG	12	O	A	Gate-drive supply for the buck-boost power stages. Apply a 4.7-μF (typical) decoupling capacitor at this pin to the power ground. The VREG pin cannot drive external loads in the application.
GND	13	—	G	Analog ground
VOS_FB	14	I	A	For the TPS55160-Q1 and TPS55162-Q1 devices, this pin is used to adjust the VOUT configuration. Connect this pin to a resistive feedback network with less than 1-MΩ total resistance between the VOUT pin, FB pin, and GND pin (analog ground). For the TPS55165-Q1 device, this pin is used to select the output voltage. The output voltage is set to 5 V when this pin is connected to the GND pin. The output voltage is 12 V when this pin is connected to the VREG pin.
PG	15	O	D	Output power good pin. This pin is an open-drain pin. The status of the power-good output is good when this pin is high (1) and has a failure when this pin is low (0)
VOUT_SENSE	16	I	A	Sense pin for the buck-boost converter output voltage. This pin must be connected to the VOUT pin.
VOUT	17	O	A	Buck-boost converter output voltage
GND	18	—	G	Analog ground
BST2	19	I	A	Bootstrap node for the boost power-stage. Connect a typical 100-nF capacitor between this pin and the L2 pin.
L2	20	I	A	Boost power-stage switch node. Connect an inductor with a nominal value of 4.7 μH between the L1 and L2 pins.
PowerPAD		—	—	The thermal pad must be soldered to the power ground to achieve the appropriate power dissipation through the analog ground plane.

(1) I = Input Pin, O = Output Pin

(2) A = Analog Pin, D = Digital Pin, G = Ground Pin, P = Power Pin

(3) The VREG_Q pin must be connected to the VREG pin at all times while the device is in operation to prevent possible electrostatic overstress (EOS) damage to the device.

7 Specifications

7.1 Absolute Maximum Ratings

over operating free-air temperature range (unless otherwise noted)^{(1) (2)}

POS			MIN	MAX	UNIT
M1.1	Protected battery voltage	VINP, VINL	-0.3	40	V
M1.2	Feedback voltage	VOS_FB	-0.3	5.5	V
M1.3	Low-power mode input	PS	-0.3	40	V
M1.4	Low-voltage inputs	IGN_PWRL, SS_EN, PG_DLY	-0.3	5.5	V
M1.5	Ignition enable input	IGN	-7	40	V
M1.6	Buck-boost output voltage	VOUT, VOUT_SENSE	-0.3	20	V
M1.7	Gate-driver supply	VREG, VREG_Q	-0.3	5.5	V
M1.8	Buck switching node voltage	L1	-0.3	40	V
M1.9	Boost switching node voltage	L2	-0.3	20	V
M1.10	Boot-strap overdrive voltage	BST1-L1, BST2-L2	-0.3	5.5	V
M1.11	Power-good output voltage	PG	-0.3	15	V
M1.12	Ground	PGND, GND	-0.3	0.3	V
M2	Junction temperature, T _J		-40	150	°C
M3	Storage temperature, T _{stg}		-65	175	°C

- (1) Stresses beyond those listed under Absolute Maximum Ratings may cause permanent damage to the device. These are stress ratings only, and functional operation of the device at these or any other conditions beyond those indicated under Recommended Operating Conditions is not implied. Exposure to absolute-maximum-rated conditions for extended periods may affect device reliability.
- (2) All voltage values are with respect to the network ground terminal unless otherwise noted

7.2 ESD Ratings

				VALUE	UNIT	
M4	V _(ESD)	Electrostatic discharge	Human-body model (HBM), per AEC Q100-002 ⁽¹⁾	±2000	V	
M5.1			Charged-device model (CDM), per AEC Q100-011	All pins		±500
M5.2				Corner pins (1, 10, 11, and 20)		±750

- (1) AEC Q100-002 indicates that HBM stressing shall be in accordance with the ANSI/ESDA/JEDEC JS-001 specification.

7.3 Recommended Operating Conditions

over operating free-air temperature range (unless otherwise noted)

POS			MIN	MAX	UNIT
R1.1a	Supply voltage at VINP and VINL pins (after wake-up)	TPS55165-Q1 with VOS_FB pin connected to GND	2	36	V
R1.1b		TPS55165-Q1 with VOS_FB pin connected to VREG	4	36	V
R1.1c		TPS55160-Q1 and TPS55162-Q1	3.6	36	V
R1.2a	Output voltage at VOUT and VOUT_SENSE pins		0	12	V
R1.2b	Output voltage at PG pin		0	5	V
R1.3	Input voltage on IGN pin		0	36	V
R1.4	Input voltage on logic pins IGN_PWRL, PS and SS_EN		0	5	V
R1.5a	Input voltage on VOS_FB pin	TPS55165-Q1	0	5	V
R1.5b		TPS55160/2-Q1	0	0.8	V
R2.1	Operating free air temperature, T _A		-40	125	°C
R2.2	Operating virtual junction temperature, T _J		-40	150	°C

7.4 Thermal Information

THERMAL METRIC ⁽¹⁾		TPS5516x-Q1	UNIT
		PWP (HTSSOP)	
		20 PINS	
R _{θJA}	Junction-to-ambient thermal resistance	35.4	°C/W
R _{θJC(top)}	Junction-to-case (top) thermal resistance	19.8	°C/W
R _{θJB}	Junction-to-board thermal resistance	16.8	°C/W
ψ _{JT}	Junction-to-top characterization parameter	0.5	°C/W
ψ _{JB}	Junction-to-board characterization parameter	16.5	°C/W
R _{θJC(bot)}	Junction-to-case (bottom) thermal resistance	0.9	°C/W

(1) For more information about traditional and new thermal metrics, see the [Semiconductor and IC Package Thermal Metrics application report](#).

7.5 Electrical Characteristics — External Components

Over operating free air temperature range $-40^{\circ}\text{C} \leq T_A \leq 125^{\circ}\text{C}$ and maximum junction temperature $T_J = 150^{\circ}\text{C}$ and recommended operating input supply range (unless otherwise noted)⁽¹⁾

POS	PARAMETER		TEST CONDITIONS	MIN	TYP	MAX	UNIT
AN.1	C _{OUT}	Value of output ceramic capacitor	Connect between VOUT and PGND	18	22	47	μF
AN.1a	ESR C _{OUT}	Value of ESR of output capacitor, C _{OUT}		0		100	mΩ
AN.2	C _{BST}	Value of bootstrap ceramic capacitor	ESR < 10 mΩ. Connect between BST1 and L1 with respect to BST2 and L2		100		nF
AN.2a	ESR C _{BST}	Value of ESR of bootstrap ceramic capacitor, C _{BST}		0		10	mΩ
AN.3	L	Value of inductor	Saturation current > 2.5 A, ESR < 30 mΩ	3.3	4.7	6.2	μH
AN.3a	DCR L	Value of DCR of inductor		0		40	mΩ
AN.4	C _{IN}	Value of supply input ceramic capacitor	40-V compliant. Connect between VIN and PGND	8.2	10		μF
AN.4a	ESR C _{IN}	Value of ESR of input capacitor, C _{IN}		0		100	mΩ
AN.5	C _{VREG}	Decoupling capacitor on VREG pin to ground	Connect between VREG and PGND	3.9	4.7	5.6	μF
AN.5a	ESR C _{VREG}	Value of ESR of input capacitor, C _{VREG}		0		10	mΩ

(1) The term V_{IN} refers to the voltage on all supply pins VINP and VINL (unless otherwise noted).

7.6 Electrical Characteristics — Supply Voltage (VINP, VINL pins)

Over operating free air temperature range $-40^{\circ}\text{C} \leq T_A \leq 125^{\circ}\text{C}$ and maximum junction temperature $T_J = 150^{\circ}\text{C}$ and recommended operating input supply range (unless otherwise noted)⁽¹⁾

POS	PARAMETER		TEST CONDITIONS	MIN	TYP	MAX	UNIT	
1.1a	V _{IN}	Operating supply input voltage	Applied at VINP and VINL pins, after device startup	TPS55165-Q1 with VOS_FB pin connected to GND	2	14	36	V
1.1b				TPS55165-Q1 with VOS_FB pin connected to VREG	4	14	36	
1.1c				TPS55160/2-Q1	3.6	14	36	
1.2	V _{IN_startup}	Minimum input voltage for startup	Applied at VINP and VINL pins; T _J = 25°C. This minimum voltage is required until VOUT > PG _{TH_UV} ; I _{VOUT} < 400 mA, C _{VOUT} = 22 μF	5.3			V	
1.3	I _{SD}	VIN Shutdown supply current	V _{IN} = 12 V, V _{IGN} = 0 V, V _{PS} = 0 V, V _{IGN_PWRL} = 0 V, T _J = 25°C			3	μA	

Over operating free air temperature range $-40^{\circ}\text{C} \leq T_A \leq 125^{\circ}\text{C}$ and maximum junction temperature $T_J = 150^{\circ}\text{C}$ and recommended operating input supply range (unless otherwise noted)⁽¹⁾

POS	PARAMETER		TEST CONDITIONS	MIN	TYP	MAX	UNIT
1.4	I_Q	VIN Quiescent supply current	TPS55165-Q1: $V_{IN} = V_{IGN} = 12\text{ V}$, $V_{OUT} = 5\text{ V}$, $I_{OUT} = 0\text{ mA}$, $T_J = 25^{\circ}\text{C}$ Device in low-power mode, Non-switching VOS_FB pin connected to GND	0		15	μA

(1) The term V_{IN} refers to the voltage on all supply pins VINP and VINL (unless otherwise noted).

7.7 Electrical Characteristics — Reference Voltage (VOS_FB Pin) and Output Voltage (VOUT Pin)

Over operating free air temperature range $-40^{\circ}\text{C} \leq T_A \leq 125^{\circ}\text{C}$ and maximum junction temperature $T_J = 150^{\circ}\text{C}$ and recommended operating input supply range (unless otherwise noted)⁽¹⁾

POS	PARAMETER		TEST CONDITIONS	MIN	TYP	MAX	UNIT
2.1a	$V_{FB_NM_adj}$	Feedback voltage in normal mode for adjustable V_{OUT} setting ⁽²⁾	TPS55160/2-Q1: Measured at VOS_FB pin Resistive divider with total resistance $< 1\text{ M}\Omega$ connected between VOUT, VOS_FB, and GND pins	0.784	0.8	0.816	V
2.1b	$V_{FB_NM_5V}$	Feedback voltage in normal mode for V_{OUT} in fixed 5-V setting ⁽²⁾	TPS55165-Q1: Measured at VOUT_SENSE pin VOS_FB pin connected to GND; VOUT pin connected to VOUT_SENSE	4.9	5	5.1	V
2.1c	$V_{FB_NM_12V}$	Feedback voltage in normal mode for V_{OUT} in fixed 12-V setting ⁽²⁾	TPS55165-Q1: Measured at VOUT_SENSE pin VOS_FB pin connected to VREG; VOUT pin connected to VOUT_SENSE	11.76	12	12.24	V
2.2a	$V_{FB_PS_adj}$	Feedback voltage in low-power mode for adjustable V_{OUT} setting ⁽³⁾	TPS55160/2-Q1: Measured at VOS_FB pin Resistive divider with total resistance $< 1\text{ M}\Omega$ connected between VOUT, VOS_FB, and GND pins	0.776	0.8	0.824	V
2.2b	$V_{FB_PS_5V}$	Feedback voltage in low-power mode for V_{OUT} in 5-V setting ⁽³⁾	TPS55165-Q1: Measured at VOUT_SENSE pin VOS_FB pin connected to GND; VOUT pin connected to VOUT_SENSE	4.85	5	5.15	V
2.2c	$V_{FB_PS_12V}$	Feedback voltage in low-power mode for V_{OUT} in 12-V setting ⁽³⁾	TPS55165-Q1: Measured at VOUT_SENSE pin VOS_FB pin connected to VREG; VOUT pin connected to VOUT_SENSE	11.64	12	12.36	V
2.3	V_{OUT_OL}	Adjustable output voltage range	TPS55160/2-Q1: Measured at VOUT_SENSE pin	5.7		9	V
2.6	R_{pdVOUT}	Pulldown discharge resistance at VOUT	Device in OFF state, INIT state, or PRE_RAMP state; $V_{IGN} = 0\text{ V}$, $V_{PS} = 0\text{ V}$, $V_{IGN_PWRL} = 0\text{ V}$	250	365	850	Ω

(1) The term V_{IN} refers to the voltage on all supply pins VINP and VINL (unless otherwise noted).

(2) $V_{PS} = 0\text{ V}$; Average DC value excluding ripple and load transients for V_{IN} and load current ranges as specified in I_{VOUT} . Inclusive DC line and load regulation, temperature drift, and long term drift.

(3) $V_{PS} = 5\text{ V}$; Average DC value excluding ripple and load transients for V_{IN} and load current ranges as specified in I_{VOUT} . Inclusive DC line and load regulation, temperature drift, and long term drift.

7.8 Electrical Characteristics — Buck-Boost

Over operating free air temperature range $-40^{\circ}\text{C} \leq T_A \leq 125^{\circ}\text{C}$ and maximum junction temperature $T_J = 150^{\circ}\text{C}$ and recommended operating input supply range (unless otherwise noted)⁽¹⁾

POS	PARAMETER	TEST CONDITIONS	MIN	TYP	MAX	UNIT		
3.1a	$I_{\text{OUT}_5\text{V}}$	Max output current in normal operation for VOUT in 5-V setting TPS55165-Q1 with VOS_FB pin connected to GND	$6\text{ V} \leq V_{\text{IN}}; \text{DCR} \leq 40\text{ m}\Omega$		1	A		
3.1b			$3.8\text{ V} \leq V_{\text{IN}} \leq 6\text{ V}; \text{DCR} \leq 40\text{ m}\Omega$		800	mA		
3.1c			$2.3\text{ V} \leq V_{\text{IN}} < 3.8\text{ V}; \text{DCR} \leq 40\text{ m}\Omega$		400			
3.1d			$2\text{ V} \leq V_{\text{IN}} < 2.3\text{ V}; \text{DCR} \leq 40\text{ m}\Omega$		200			
3.1e	$I_{\text{OUT}_12\text{V}}$	Max output current in normal operation for VOUT in 12-V setting TPS55165-Q1 with VOS_FB pin connected to VREG	$14\text{ V} \leq V_{\text{IN}}; \text{DCR} \leq 40\text{ m}\Omega$		800	mA		
3.1f			$9.2\text{ V} \leq V_{\text{IN}} \leq 14\text{ V}; \text{DCR} \leq 40\text{ m}\Omega$		600			
3.1g			$5.6\text{ V} \leq V_{\text{IN}} < 9.2\text{ V}; \text{DCR} \leq 40\text{ m}\Omega$		300			
3.1h			$4\text{ V} \leq V_{\text{IN}} < 5.6\text{ V}; \text{DCR} \leq 40\text{ m}\Omega$		150			
3.2a	$I_{\text{OUT}_\text{adj}_\text{VoutH}}$	Max output current in normal operation for adjustable configuration, $8\text{V} < V_{\text{OUT}} \leq 9\text{V}$ TPS55160-Q1 and TPS55162-Q1, $8\text{V} < V_{\text{OUT}} \leq 9\text{V}$	$(V_{\text{OUT}} + 2\text{V}) \leq V_{\text{IN}}; \text{DCR} \leq 40\text{ m}\Omega$		800	mA		
3.2b			$0.76 * V_{\text{OUT}} \leq V_{\text{IN}} \leq (V_{\text{OUT}} + 2\text{V}); \text{DCR} \leq 40\text{ m}\Omega$		600			
3.2c			$0.46 * V_{\text{OUT}} \leq V_{\text{IN}} < 0.76 * V_{\text{OUT}}; \text{DCR} \leq 40\text{ m}\Omega$		300			
3.2d			$3.6\text{ V} \leq V_{\text{IN}} < 0.46 * V_{\text{OUT}}; \text{DCR} \leq 40\text{ m}\Omega$		150			
3.2e	$I_{\text{OUT}_\text{adj}_\text{VoutL}}$	Max output current in normal operation for adjustable configuration, $5.7\text{V} \leq V_{\text{OUT}} \leq 8\text{V}$ TPS55160-Q1 and TPS55162-Q1, $5.7\text{V} \leq V_{\text{OUT}} \leq 8\text{V}$	$(V_{\text{OUT}} + 1\text{V}) \leq V_{\text{IN}}; \text{DCR} \leq 40\text{ m}\Omega$		800	mA		
3.2f			$0.76 * V_{\text{OUT}} \leq V_{\text{IN}} < (V_{\text{OUT}} + 1\text{V}); \text{DCR} \leq 40\text{ m}\Omega$		600			
3.2g			$3.6\text{ V} \leq V_{\text{IN}} < 0.76 * V_{\text{OUT}}; \text{DCR} \leq 40\text{ m}\Omega$		300			
3.11	I_{OUT_PS}	Max output current in low-power mode		50				
3.3	$R_{\text{dson_BUCK_HS}}$	On-resistance buck-stage high-side (HS) FET		150	300	mΩ		
3.4	$R_{\text{dson_BUCK_LS}}$	On-resistance buck-stage low-side (LS) FET		150	300	mΩ		
3.5	$R_{\text{dson_BOOST_HS}}$	On-resistance boost-stage HS FET		150	300	mΩ		
3.6	$R_{\text{dson_BOOST_LS}}$	On-resistance boost-stage LS FET		150	300	mΩ		
3.7	$I_{\text{SW_limit}}$	Peak current limit for HS buck, LS buck, and LS boost	Device in normal operating mode		2	3.5	4.5	A
3.9	$I_{\text{CoilAvglimit}}$	Average coil current limit	Device in normal operating mode; $L = 4.7\text{ }\mu\text{H}$		2	2.8		A
3.20a	$V_{\text{TLDSR}_5\text{V}_100}$	Transient load step response for VOUT in 5-V setting	TPS55165-Q1: Measured at VOUT_SENSE pin; VOS_FB pin connected to GND; $V_{\text{IN}} = 12\text{ V}$, $I_{\text{OUT}} = 0.1\text{ A}$ to 0.5 A , $T_R = T_F = 1\text{ }\mu\text{s}$, $C_{\text{OUT}} = 47\text{ }\mu\text{F}$		5			
3.20b	$V_{\text{TLDSR}_5\text{V}_500}$	Transient load step response for VOUT in 5-V setting	TPS55165-Q1: Measured at VOUT_SENSE pin; VOS_FB pin connected to GND; $V_{\text{IN}} = 12\text{ V}$, $I_{\text{OUT}} = 0.5\text{ A}$ to 1 A , $T_R = T_F = 1\text{ }\mu\text{s}$, $C_{\text{OUT}} = 47\text{ }\mu\text{F}$		5			
3.21a	$V_{\text{RIPPLE}_5\text{V}}$	Output ripple for VOUT in 5-V setting	TPS55165-Q1: Measured at VOUT_SENSE pin; VOS_FB pin connected to GND; $V_{\text{IN}} = 12\text{V}$, $I_{\text{OUT}} = 1\text{ A}$, $\text{SS_EN} = \text{low}$		5.5			mVpp
3.21b	$V_{\text{RIPPLE}_12\text{V}}$	Output ripple for VOUT in 12-V setting	TPS55165-Q1: Measured at VOUT_SENSE pin; VOS_FB pin connected to VREG; $V_{\text{IN}} = 14\text{V}$, $I_{\text{OUT}} = 0.8\text{ A}$, $\text{SS_EN} = \text{low}$		5			mVpp

(1) The term V_{IN} refers to the voltage on all supply pins VINP and VINL (unless otherwise noted).

7.9 Electrical Characteristics — Undervoltage and Overvoltage Lockout

Over operating free air temperature range $-40^{\circ}\text{C} \leq T_A \leq 125^{\circ}\text{C}$ and maximum junction temperature $T_J = 150^{\circ}\text{C}$ and recommended operating input supply range (unless otherwise noted)⁽¹⁾

POS	PARAMETER		TEST CONDITIONS	MIN	TYP	MAX	UNIT
4.1a	UVLO	V_{IN} Undervoltage (UV) lockout threshold	V_{IN} voltage decreasing; Device turned-off when $V_{IN} < UVLO$	1.8		2	V
4.1b			Device is in normal operating mode				
4.1c	UVLO	V_{IN} Undervoltage (UV) lockout threshold	V_{IN} voltage decreasing; Device turned-off when $V_{IN} < UVLO$ Device is in normal operating mode	1.8		2	V
4.2	OVLO	V_{IN} Overvoltage (OV) lockout threshold	V_{IN} voltage increasing; Device stops switching when $V_{IN} > OVLO$, and recovers when $V_{IN} < OVLO$ and $IGN = 1$ Device is in normal operating mode	36		40	V
4.9	$V_{OUT_PROT_OV}$	V_{OUT} OV protection	Device is in normal operating mode	110%		125%	

(1) The term V_{IN} refers to the voltage on all supply pins VINP and VINL (unless otherwise noted).

7.10 Electrical Characteristics — IGN Wakeup

Over operating free air temperature range $-40^{\circ}\text{C} \leq T_A \leq 125^{\circ}\text{C}$ and maximum junction temperature $T_J = 150^{\circ}\text{C}$ and recommended operating input supply range (unless otherwise noted)⁽¹⁾

POS	PARAMETER		TEST CONDITIONS	MIN	TYP	MAX	UNIT
5.1a	IGN_{WAKE}	IGN wake-up threshold	V_{IGN} voltage increasing to wake-up device	2.5	3.1	3.7	V
5.1b	IGN_{PD}	IGN power-down threshold	V_{IGN} voltage decreasing to power-down device	1.5	2.1	2.7	V
5.2	IGN_{HYST}	IGN wake-up hysteresis		0.76	1	1.35	V
5.3a	$I_{IGN_{36V}}$	IGN pin forward input current at 36 V	$V_{IGN} = 36\text{ V}$	11	17	30	μA
5.3b	$I_{IGN_{12V}}$	IGN pin forward input current at 12 V	$V_{IGN} = 12\text{ V}$	2.3	3.7	7.1	μA
5.5	$I_{IGN_{rev}}$	IGN pin reverse current	$V_{IGN} = -7\text{ V}$		370	650	μA

(1) The term V_{IN} refers to the voltage on all supply pins VINP and VINL (unless otherwise noted).

7.11 Electrical Characteristics — Logic Pins PS, IGN_PWRL, SS_EN

Over operating free air temperature range $-40^{\circ}\text{C} \leq T_A \leq 125^{\circ}\text{C}$ and maximum junction temperature $T_J = 150^{\circ}\text{C}$ and recommended operating input supply range (unless otherwise noted)⁽¹⁾

POS	PARAMETER		TEST CONDITIONS	MIN	TYP	MAX	UNIT
6.1	$V_{LOGIC_IN_HIGH}$	Logic input low-to-high threshold for pins IGN_PWRL, PS, and SS_EN	Device in power-up condition	2			V
6.2	$V_{LOGIC_IN_LOW}$	Logic Input high-to-low threshold for pins IGN_PWRL, PS, and SS_EN	Device in power-up condition			0.74	V
6.3	$V_{LOGIC_IN_HYST}$	Logic input hysteresis for pins IGN_PWRL, PS, and SS_EN	Device in power-up condition	0.15		0.39	V
6.4	$R_{LOGIC_IN_PD}$	Pulldown resistance on PS pin to GND		35	70	111	k Ω
6.5	$I_{pull-up_SS_EN}$	Pullup current on SS_EN pin		85		266	μA

Over operating free air temperature range $-40^{\circ}\text{C} \leq T_A \leq 125^{\circ}\text{C}$ and maximum junction temperature $T_J = 150^{\circ}\text{C}$ and recommended operating input supply range (unless otherwise noted)⁽¹⁾

POS	PARAMETER		TEST CONDITIONS	MIN	TYP	MAX	UNIT
6.6	$I_{\text{pull-up_IGN_PWRL}}$	Pullup current on IGN_PWRL pin		1		8	μA

(1) The term V_{IN} refers to the voltage on all supply pins VINP and VINL (unless otherwise noted).

7.12 Electrical Characteristics – Overtemperature Protection

Over operating free air temperature range $-40^{\circ}\text{C} \leq T_A \leq 125^{\circ}\text{C}$ and maximum junction temperature $T_J = 150^{\circ}\text{C}$ and recommended operating input supply range (unless otherwise noted)⁽¹⁾

POS	PARAMETER		TEST CONDITIONS	MIN	TYP	MAX	UNIT
7.1	T_{PROT}	Overtemperature shutdown protection threshold		175		210	$^{\circ}\text{C}$
7.2	T_{HYS}	Overtemperature shutdown hysteresis			30		

(1) The term V_{IN} refers to the voltage on all supply pins VINP and VINL (unless otherwise noted).

7.13 Electrical Characteristics – Power Good

Over operating free air temperature range $-40^{\circ}\text{C} \leq T_A \leq 125^{\circ}\text{C}$ and maximum junction temperature $T_J = 150^{\circ}\text{C}$ and recommended operating input supply range (unless otherwise noted)⁽¹⁾

POS	PARAMETER		TEST CONDITIONS	MIN	TYP	MAX	UNIT
8.1	$\text{PG}_{\text{TH_UV}}$	PG threshold undervoltage	Deviation from nominal V_{OUT} to assert PG low, in normal mode	-10%		-5%	
			Deviation from nominal V_{OUT} to assert PG low, during low power mode to normal mode transition		-12%		
			Deviation from nominal V_{OUT} to assert PG low, in low power mode	-20%		-5%	
8.2	$V_{\text{PG_LOW}}$	PG output-low voltage	$\text{IPGL} \leq 1\text{mA}$			0.4	V

(1) The term V_{IN} refers to the voltage on all supply pins VINP and VINL (unless otherwise noted).

7.14 Switching Characteristics — Reference Voltage (VOS_FB Pin) and Output Voltage (VOUT Pin)

Over operating free air temperature range $-40^{\circ}\text{C} \leq T_A \leq 125^{\circ}\text{C}$ and maximum junction temperature $T_J = 150^{\circ}\text{C}$ and recommended operating input supply range (unless otherwise noted)⁽¹⁾

POS	PARAMETER		TEST CONDITIONS	MIN	TYP	MAX	UNIT
2.5	$t_{\text{start_VOUT}}$	VOUT startup time	$L = 4.7 \mu\text{H}$, $C_{\text{OUT}} = 22 \mu\text{F}$; V_{OUT} rising from 10% to 90% of final value		1.5		ms

(1) The term V_{IN} refers to the voltage on all supply pins VINP and VINL (unless otherwise noted).

7.15 Switching Characteristics — Buck-Boost

Over operating free air temperature range $-40^{\circ}\text{C} \leq T_A \leq 125^{\circ}\text{C}$ and maximum junction temperature $T_J = 150^{\circ}\text{C}$ and recommended operating input supply range (unless otherwise noted)⁽¹⁾

POS	PARAMETER		TEST CONDITIONS	MIN	TYP	MAX	UNIT
3.8	$t_{\text{blank_Iswlim}}$	Time until peak current limit is active	$V_{\text{IN}} = 14\text{ V}$	40		70	ns
3.11	f_{SW}	Switching frequency without Spread-Spectrum	$V_{\text{IN_max}} = 27\text{ V}$	1860	2000	2140	kHz
3.12	$f_{\text{SW_SS}}$	Switching frequency with Spread-Spectrum Enabled	$V_{\text{IN_max}} = 27\text{ V}$; SS_EN pin not connected to GND; Device in buck operation	1800	2100	2400	kHz
3.14	$t_{\text{on_Min_Buck}}$	Minimum on time in buck operation	Device in normal operation mode		55	65	ns
3.15	$t_{\text{on_Max_Boost}}$	Maximum on time in boost operation	Device in normal operation mode	350	400	450	ns
3.16	$t_{\text{on_Max_Bst_LP M}}$	Maximum boost on time in power save mode			4		μs

(1) The term V_{IN} refers to the voltage on all supply pins VINP and VINL (unless otherwise noted).

7.16 Switching Characteristics — Undervoltage and Overvoltage Lockout

Over operating free air temperature range $-40^{\circ}\text{C} \leq T_A \leq 125^{\circ}\text{C}$ and maximum junction temperature $T_J = 150^{\circ}\text{C}$ and recommended operating input supply range (unless otherwise noted)⁽¹⁾

POS	PARAMETER		TEST CONDITIONS	MIN	TYP	MAX	UNIT
4.3	$t_{\text{degl_VINUVOV}}$	V_{IN} UV and OV deglitch time		40	50	60	μs
4.8	$t_{\text{degl_VREGUVOV}}$	VREG UV and OV deglitch time			10		μs

(1) The term V_{IN} refers to the voltage on all supply pins VINP and VINL (unless otherwise noted).

7.17 Switching Characteristics — IGN Wakeup

Over operating free air temperature range $-40^{\circ}\text{C} \leq T_A \leq 125^{\circ}\text{C}$ and maximum junction temperature $T_J = 150^{\circ}\text{C}$ and recommended operating input supply range (unless otherwise noted)⁽¹⁾

POS	PARAMETER		TEST CONDITIONS	MIN	TYP	MAX	UNIT
5.6	IGN_deg	IGN deglitch filter time		7.5		22	ms
5.7	IGN _{startup_time}	Time from IGN high till VOUT crossing 95% of the end-value				25	ms

(1) The term V_{IN} refers to the voltage on all supply pins VINP and VINL (unless otherwise noted).

7.18 Switching Characteristics — Logic Pins PS, IGN_PWRL, SS_EN

Over operating free air temperature range $-40^{\circ}\text{C} \leq T_A \leq 125^{\circ}\text{C}$ and maximum junction temperature $T_J = 150^{\circ}\text{C}$ and recommended operating input supply range (unless otherwise noted)⁽¹⁾

POS	PARAMETER		TEST CONDITIONS	MIN	TYP	MAX	UNIT
6.7	$t_{\text{Delay_IGN_PWRL}}$	Input Delay time for IGN_PWRL pin	Delay time between the toggling of the IGN_PWRL pin and the state change of the signal inside the device	213	256	272	μs
6.8a	$t_{\text{Delay_PS_L2H}}$	Input Delay time for PS pin pulling high	Delay time between pulling the PS high and the device enters low-power mode	59		136	μs
6.8b	$t_{\text{Delay_PS_H2L}}$	Input Delay time for PS pin going low	Delay time between releasing the PS pin and the device enters normal mode from low-power mode	262		510	μs

(1) The term V_{IN} refers to the voltage on all supply pins VINP and VINL (unless otherwise noted).

7.19 Switching Characteristics – Power Good

Over operating free air temperature range $-40^{\circ}\text{C} \leq T_A \leq 125^{\circ}\text{C}$ and maximum junction temperature $T_J = 150^{\circ}\text{C}$ and recommended operating input supply range (unless otherwise noted)⁽¹⁾

POS	PARAMETER		TEST CONDITIONS	MIN	TYP	MAX	UNIT
8.3	PG _{Deglitch}	PG deglitch filter time		45	50	55	μs
8.4a	PG _{exttime}	PG extension time (rising edge only)	PG_DLY Shorted to VREG		40		ms
8.4b			100 kΩ between PG_DLY and GND		30		
8.4c			10 kΩ between PG_DLY and GND		4		ms
8.4d			PG_DLY grounded		0.7		ms

(1) The term V_{IN} refers to the voltage on all supply pins VINP and VINL (unless otherwise noted).

7.20 Typical Characteristics

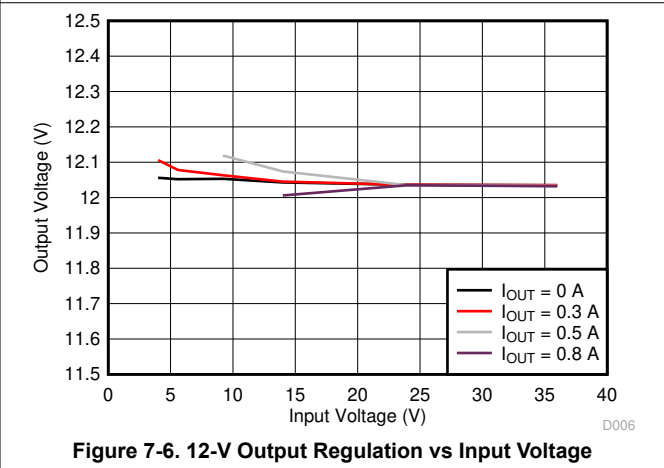
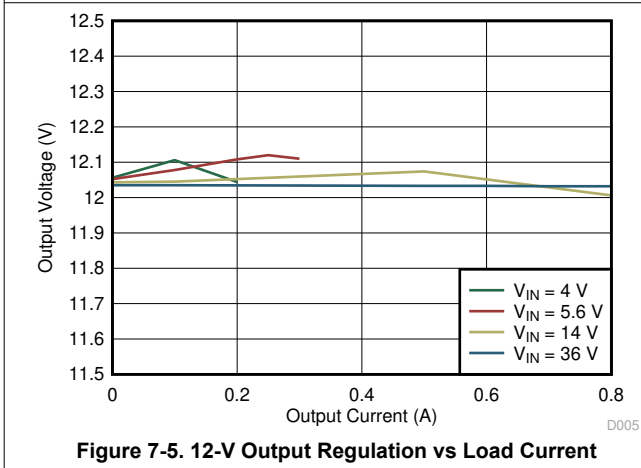
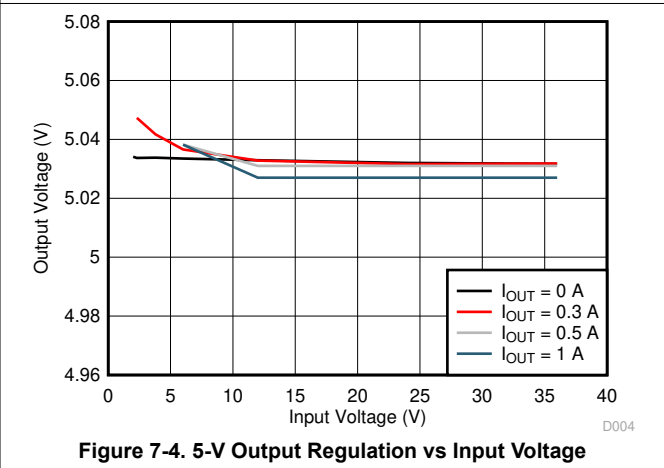
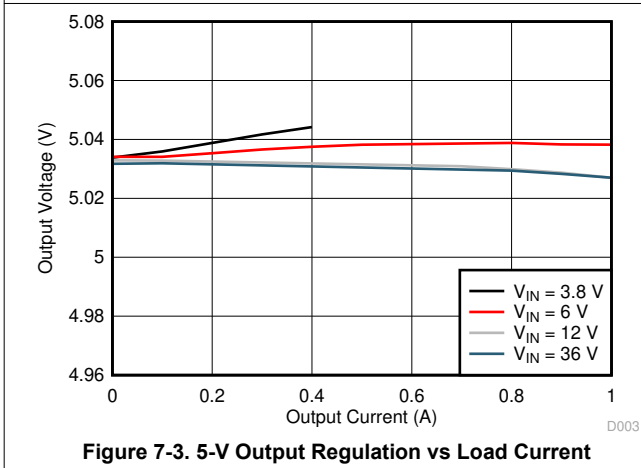
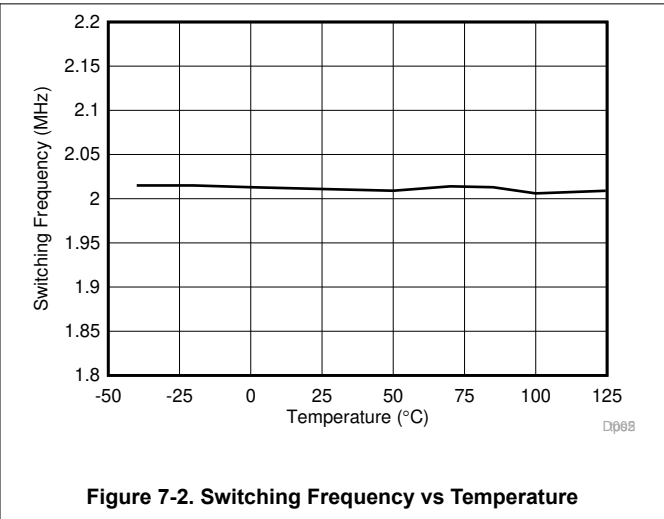
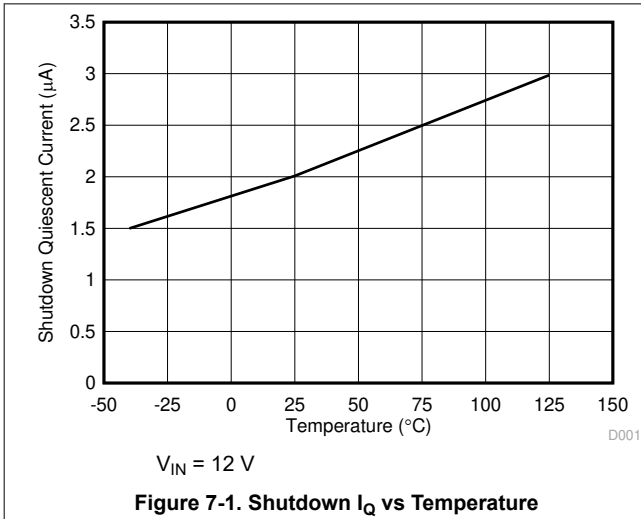

7.20 Typical Characteristics (continued)

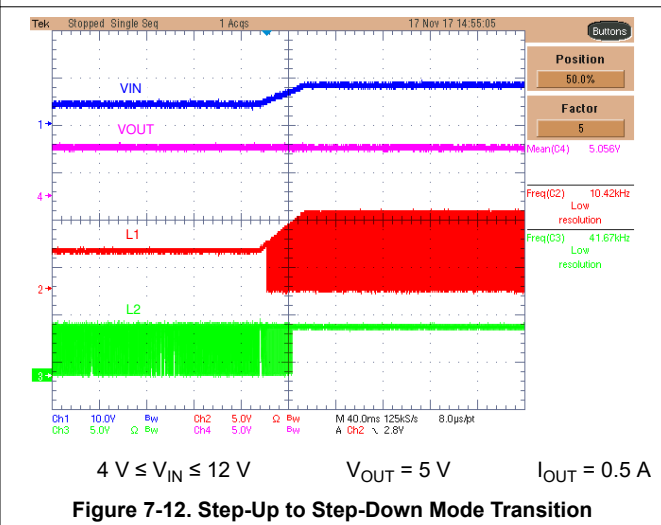
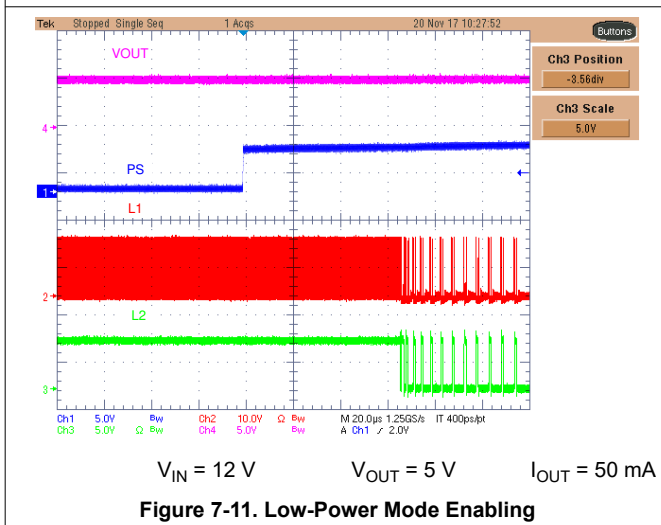
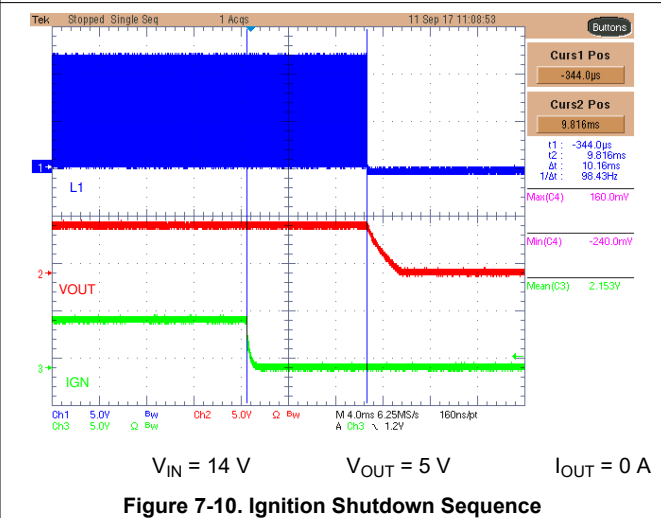
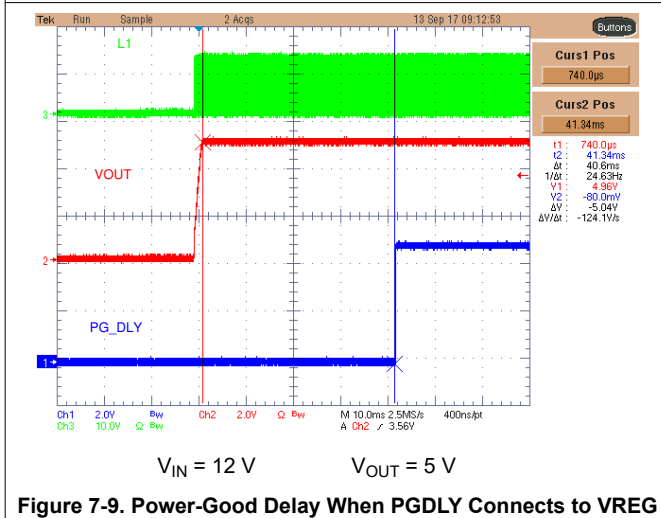
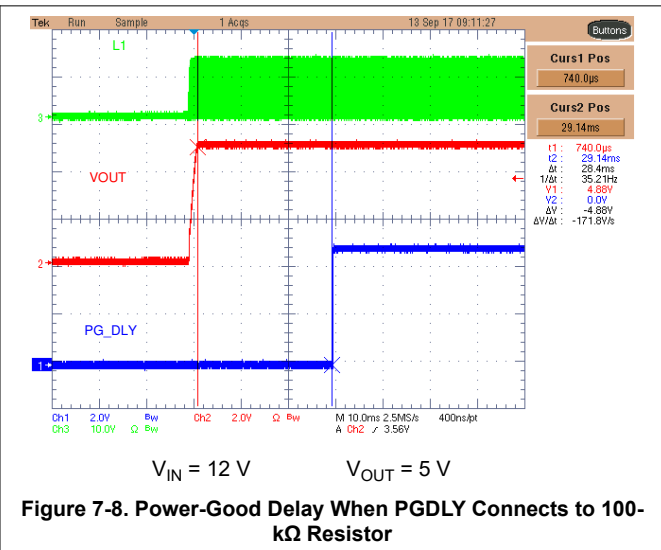
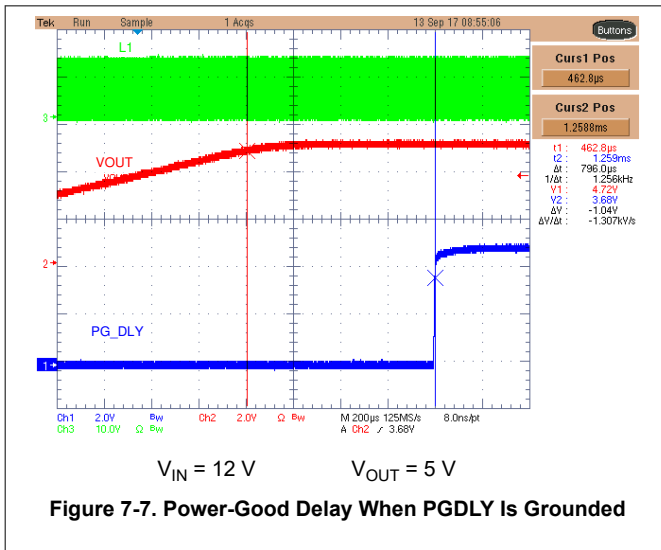

7.20 Typical Characteristics (continued)

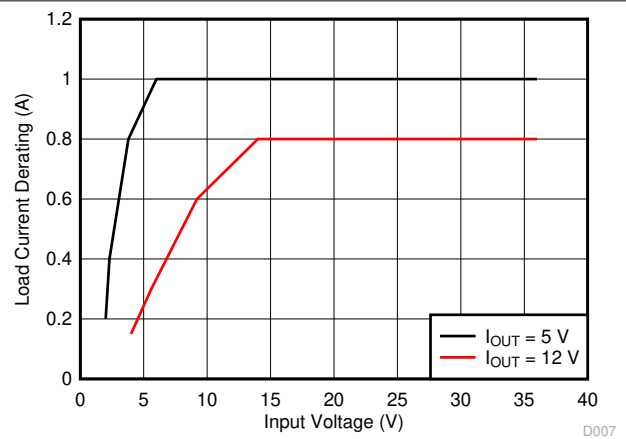
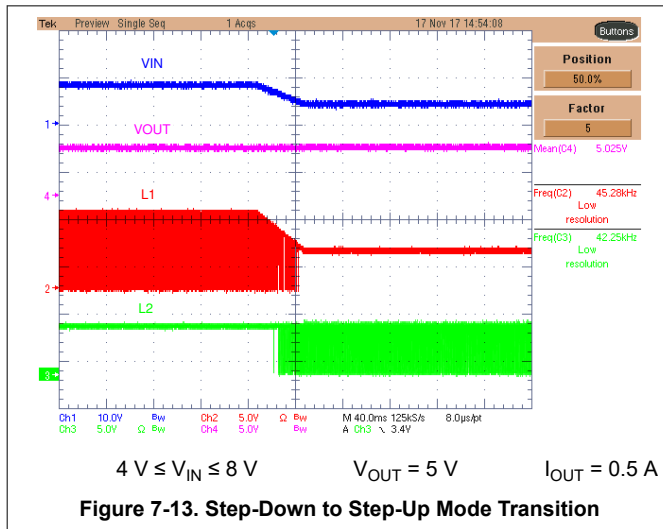

Figure 7-14. Load Current Derating vs Input Voltage

8 Detailed Description

8.1 Overview

The control circuit of the TPS5516x-Q1 buck-boost converter is based on an average current-mode topology. The control circuit also uses input and output voltage feedforward. Changes of input and output voltage are monitored and the duty cycle in the modulator is immediately adapted to achieve a fast response to those changes. The voltage error amplifier gets its feedback input from the VOS_FB pin. The feedback voltage is compared with the internal reference voltage to generate a stable and accurate output voltage.

The buck-boost converter uses four internal N-channel MOSFETs to maintain synchronous power conversion at all possible operating conditions. This feature enables the device to keep high efficiency over a wide input voltage and output power range. To avoid ground shift problems caused by the high currents in the switches, separate ground pins (GND and PGND) are used. The reference for all control functions are the GND pins. The power switches are connected to the PGND pins. Both grounds must be connected on the PCB at only one point which is ideally close to the GND pin. Because of the 4-switch topology, the load is always disconnected from the input during shutdown of the converter.

To drive the high-side switches of the buck and the boost power stages, the buck-boost converter requires external boot-strapping ceramic capacitors with low ESR. These bootstrap capacitors are charged by the VREG supply. The VREG supply requires a low-ESR ceramic capacitor for loop stabilization, and must not be loaded by the external application. The VREG supply is also used to drive the low-side switches of the buck and boost power stages. At device start-up, the VREG pin is supplied by the input voltage. When the buck-boost output voltage is greater than its power-good threshold (the PG pin is high), the VREG pin is supplied by the output voltage to reduce power dissipation.

The device can be enabled with the IGN pin, and, when enabled, the device has a power-latch function which can be selected with the IGN_PWRL pin. This function allows an external MCU to keep TPS5516x-Q1 device on even after the IGN pin goes low.

For the TPS55160-Q1 and TPS55165-Q1 devices, the operation mode of the buck-boost converter can be selected through the PS pin. When the PS pin is low, the buck-boost operates in normal mode with a constant fixed switching frequency. When the PS pin is high, the buck-boost operates in low-power mode with pulse-frequency modulation.

The TPS55160-Q1 and TPS55165-Q1 devices also have a frequency spread-spectrum option that can be enabled or disabled through the SS_EN pin.

The output voltage of the TPS55165-Q1 device is selected as a fixed 5 V or fixed 12 V through the VOS_FB pin. The TPS55160-Q1 and TPS55162-Q1 devices have an adjustable output voltage from 5.7 V to 9 V through an external feedback network.

8.2 Functional Block Diagram

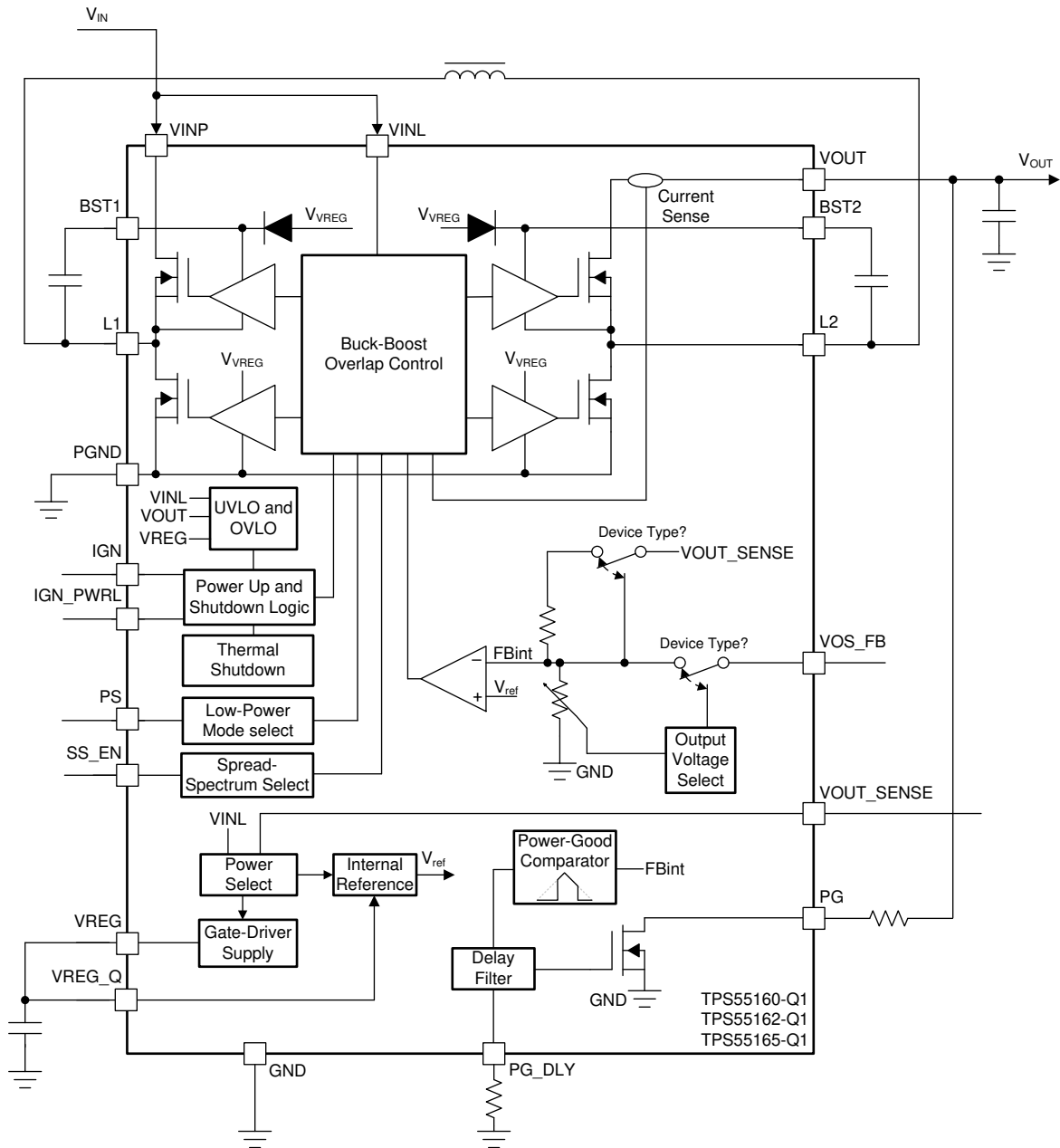

8.3 Feature Description

8.3.1 Spread-Spectrum Feature

The TPS55160-Q1 and TPS55165-Q1 devices have a spread-spectrum feature to modulate the switching frequency through a pseudo-random algorithm.

This spread-spectrum feature is enabled and disabled through the SS_EN pin. When the SS_EN pin is unconnected, the spread-spectrum feature is enabled. The SS_EN pin is internally pulled up with a pullup current between 100 μ A and 200 μ A. When the SS_EN pin is connected to ground, the spread-spectrum feature is disabled.

This feature can only be enabled when the device is in normal mode with step-down operation. This feature cannot be enabled in low-power mode.

8.3.2 Overcurrent Protection

The buck-boost regulator has two ways of protecting against overcurrent conditions. When the buck-boost is in regulation (essentially the output voltage is at the target voltage), the average current limit provides the protection against overcurrent conditions. When the average current limit is activated (essentially the maximum inductor average current is reached), the output voltage gradually decreases, but the control loop tries to maintain the target output voltage. So when the overcurrent condition clears before the buck-boost control circuit gets too far out of regulation, the output voltage gradually reaches its target voltage level again.

The buck-boost regulator limits the peak-overcurrent in the power MOSFETs. When such a peak-overcurrent event occurs, the device goes into the PRE_RAMP state and a 12-ms time-out is started. The device restarts and goes from the PRE_RAMP state to the RAMP state after this 12-ms time-out expires and the IGN pin is high.

When the device operates in low-power mode, both the average current limit and the peak-current limit protection functions are disabled.

8.3.3 Overtemperature Protection

The internal power MOSFETs are protected against excess power dissipation with junction overtemperature protection. In case of a detected overtemperature condition, the TPS55165-Q1 device goes to the PRE_RAMP state (the buck-boost regulator is switched off and the VREG supply is enabled) and a 12-ms time-out is started when the overtemperature condition is cleared. The device restarts in the PRE_RAMP state after this 12-ms time-out expires, the overtemperature condition disappeared, and the IGN pin is high.

When the device operates in low-power mode, this overtemperature protection function is disabled.

8.3.4 Undervoltage Lockout and Minimum Start-Up Voltage

The TPS55165-Q1 device has an undervoltage lockout (UVLO) function. When the device operates in normal mode (the PS pin is low), this UVLO function puts the device in the OFF state when the input voltage is less than the UVLO threshold. The device restarts when the IGN pin is high and the input voltage is greater than or equal to the minimum input voltage for start-up, which must be maintained until the output voltage is greater than the PG undervoltage threshold.

When the device operates in low-power mode, this UVLO function is disabled.

8.3.5 Overvoltage Lockout

The TPS55165-Q1 device has an overvoltage lockout (OVLO) function. When the input voltage is greater than the OVLO threshold while the device operates in normal mode (the PS pin is low), this OVLO function puts the device in the PRE_RAMP state (the buck-boost regulator is switched off and the VREG supply is enabled), and a 12-ms time-out starts. The device restarts in the PRE_RAMP state after this 12-ms time-out expires, the input voltage is less than the OVLO threshold, and the IGN pin is high.

When the device operates in low-power mode, this OVLO function is disabled.

8.3.6 VOUT Overvoltage Protection

When the device operates in normal mode (the PS pin is low) and the output voltage is greater than or equal to the VOUT overvoltage protection, the device goes to the PRE_RAMP state (the buck-boost regulator is switched-off and the VREG supply is enabled) and a 12-ms time-out starts when the output voltage is less than the VOUT overvoltage protection. The device restarts in the PRE_RAMP state after this 12-ms time-out expires, the output voltage is less than the VOUT overvoltage protection, and the IGN pin is high.

When the device operates in low-power mode, this VOUT overvoltage protection function is disabled.

8.3.7 Power-Good Pin

The power-good (PG) pin is a low-side FET open-drain output which is released as soon as the output voltage is greater than the PG undervoltage threshold (essentially the output voltage is rising) and the extension time ($PG_{exttime}$) is expired. The intended usage of this pin is to release the reset of an external MCU. Therefore, the logic-input signals (IGN_PWRL and PS) are considered to be valid only when the PG pin reaches the high level.

When the output voltage is less than the PG undervoltage threshold (essentially the output voltage is falling) for a time longer than the PG deglitch filter time, the PG pin is pulled low. When the PG pin is low, the level of the PS and IGN_PWRL pins is interpreted as low, regardless of the actual level. The device goes to the OFF state if the IGN pin is low under this condition. For more information on the behavior of the PG pin for rising and falling output voltage, see [Figure 8-2](#) through [Figure 8-6](#).

The PG pin is operational in low-power mode. The PG extension time can be configured by connecting the PG_DLY pin to the VREG pin, the GND pin, or through an external resistor with a value from 10 k Ω to 100 k Ω to the GND pin. The extension time is as follows for the listed configurations:

- When the PG_DLY pin is shorted to the VREG pin, the typical PG extension time is 40 ms.
- When the PG_DLY pin is connected to the GND pin, the typical PG extension time is 0.6 ms.
- When the external resistor between the PG_DLY and GND pins has a value of 10 k Ω , the typical PG extension time is 3 ms.
- When the external resistor between pin the PG_DLY and GND pins has a value of 100 k Ω , the typical PG extension time is 30 ms.

8.4 Device Functional Modes

8.4.1 State Diagram

[Figure 8-1](#) shows the state diagram.

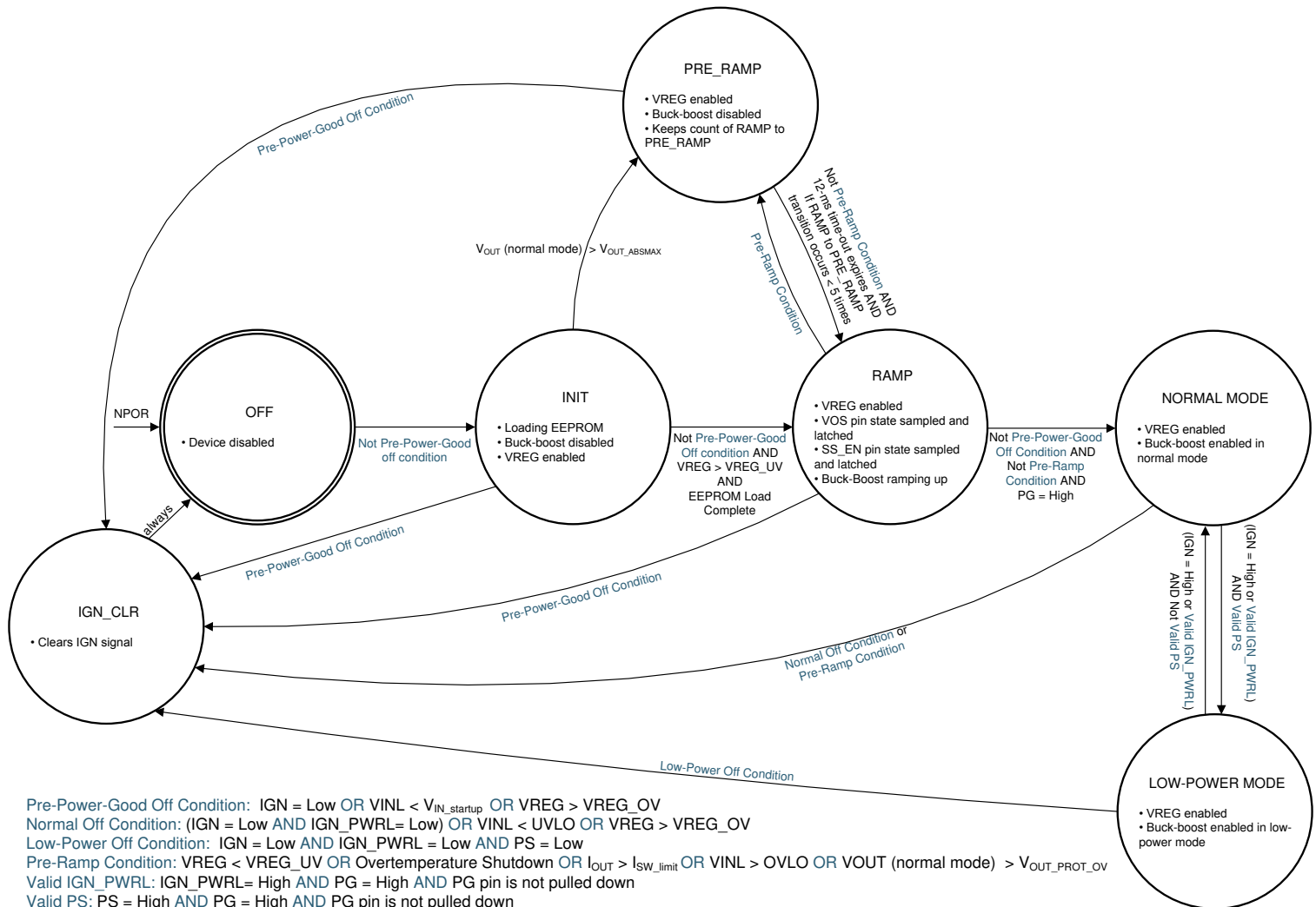

- The 12-ms time-out from the PRE_RAMP state to the RAMP state starts only when all conditions for going to the RAMP state are satisfied. As soon as one of these conditions is violated, the 12-ms time-out is reset.
- The oscillator is turned off in low-power mode. The oscillator is turned back on upon detecting a negative edge on the PS pin, or a negative edge on the PG pin which requires the device to go out of low-power mode and enter normal mode again.

Figure 8-1. State Diagram

8.4.2 Modes of Operation

The operational mode of the buck-boost converter is selected through the PS pin. When the PS pin is low, the buck-boost operates in normal mode with a constant fixed switching frequency. When the PS pin is high, the buck-boost operates in low-power mode with pulse-frequency modulation.

8.4.2.1 Normal Mode

To regulate the output voltage at all possible input voltage conditions, the buck-boost converter automatically switches from step-down operation to boost operation and back as required by the configuration. The regulator always uses one active switch, one rectifying switch, one always-on switch, and one always-off switch. Therefore, the regulator operates as a step-down converter (buck) when the input voltage is higher than the output voltage, and as a boost converter when the input voltage is lower than the output voltage. In normal mode, no mode of operation is available in which all four switches are permanently switching. Controlling the switches in this way allows the converter to maintain high efficiency at the most important point of operation; when the input voltage is close to the output voltage. The RMS current through the switches and the inductor

is kept at a minimum to minimize switching and conduction losses. For the remaining two switches, one is kept permanently on and the other is kept permanently off which causes no switching losses.

In normal mode, the converter operates in full continuous mode at a fixed switching frequency of 2 MHz (typical) for the entire load-current range, even with no load at the output. No pulse-skipping should occur for supply voltages from 2 V to 27 V.

8.4.2.2 Low-Power Mode

When the buck-boost converter is in low-power mode, the output voltage is monitored with a comparator with its threshold at the regulation target voltage. When the buck-boost regulator goes to low-power mode, the converter temporarily stops operating and the output voltage drops. The slope of the output voltage depends on the load and output capacitance. As the output voltage decreases to less than the regulation target voltage, the device ramps up the output voltage again by giving one or several pulses until the output voltage exceeds the regulation target voltage. In low-power mode, the buck-boost operates in 4-switch mode, which allows regulation at the target output voltage regardless of whether the input voltage is greater than or less than the target output voltage value.

After the device enters low-power mode, the internal oscillator is turned off. As a result of the oscillator being turned off, all signal deglitching functions are disabled while the device is in low-power mode. These functions include the V_{IN} and VREG OV and UV signal deglitch functions, and the IGN input signal deglitch function.

8.4.3 Power-Up and Power-Down Sequences

Figure 8-2 shows the power-up and power-down sequence without the usage of the IGN_PWRL pin.

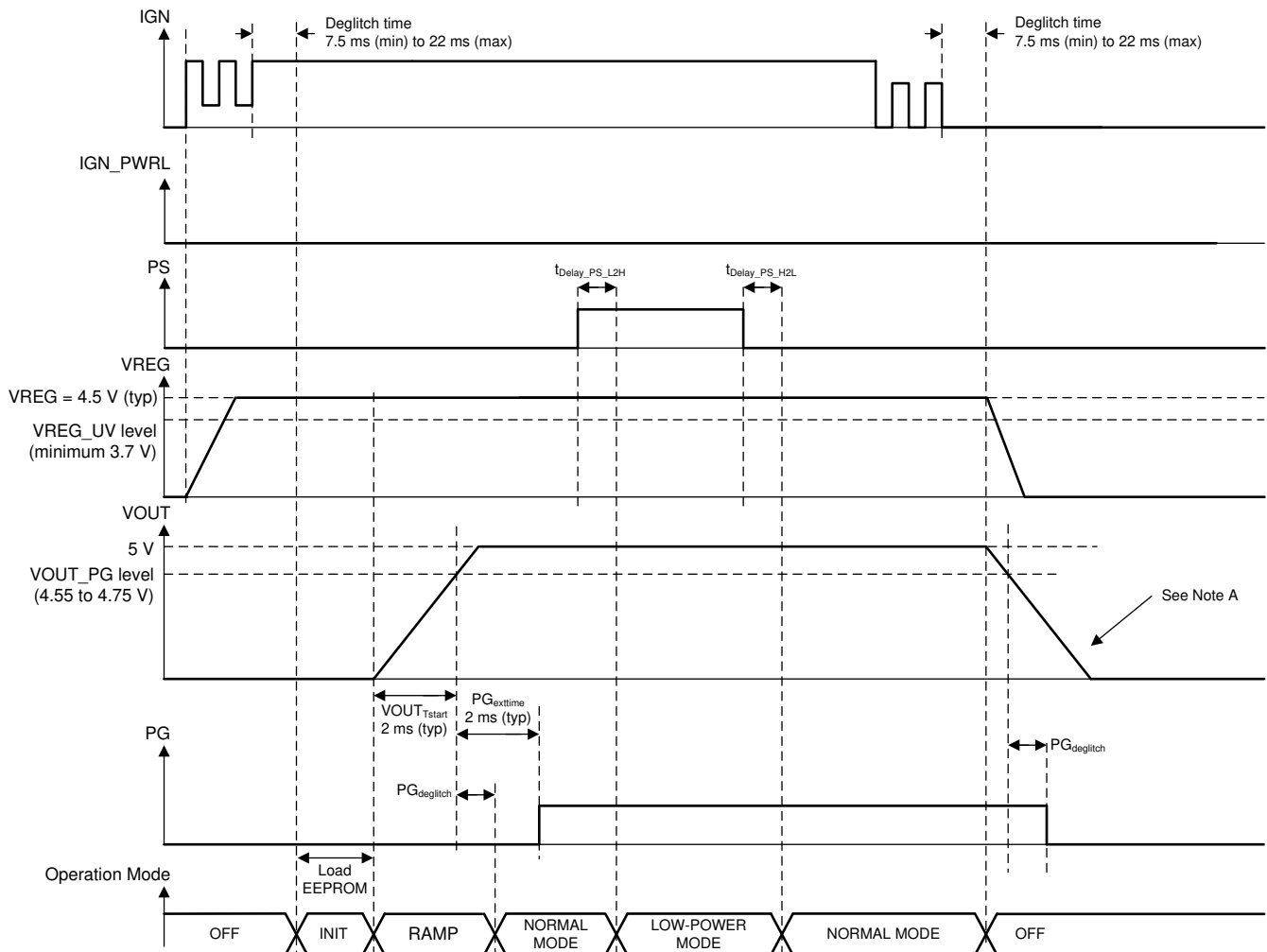

A. The actual ramp-down time of the output voltage depends on external load conditions.

Figure 8-2. Power-Up and Power-Down Sequence With Normal Mode and Low-Power Mode, Without Usage of IGN_PWRL

Figure 8-3 shows the power-up and power-down sequence with usage of the IGN_PWRL pin.

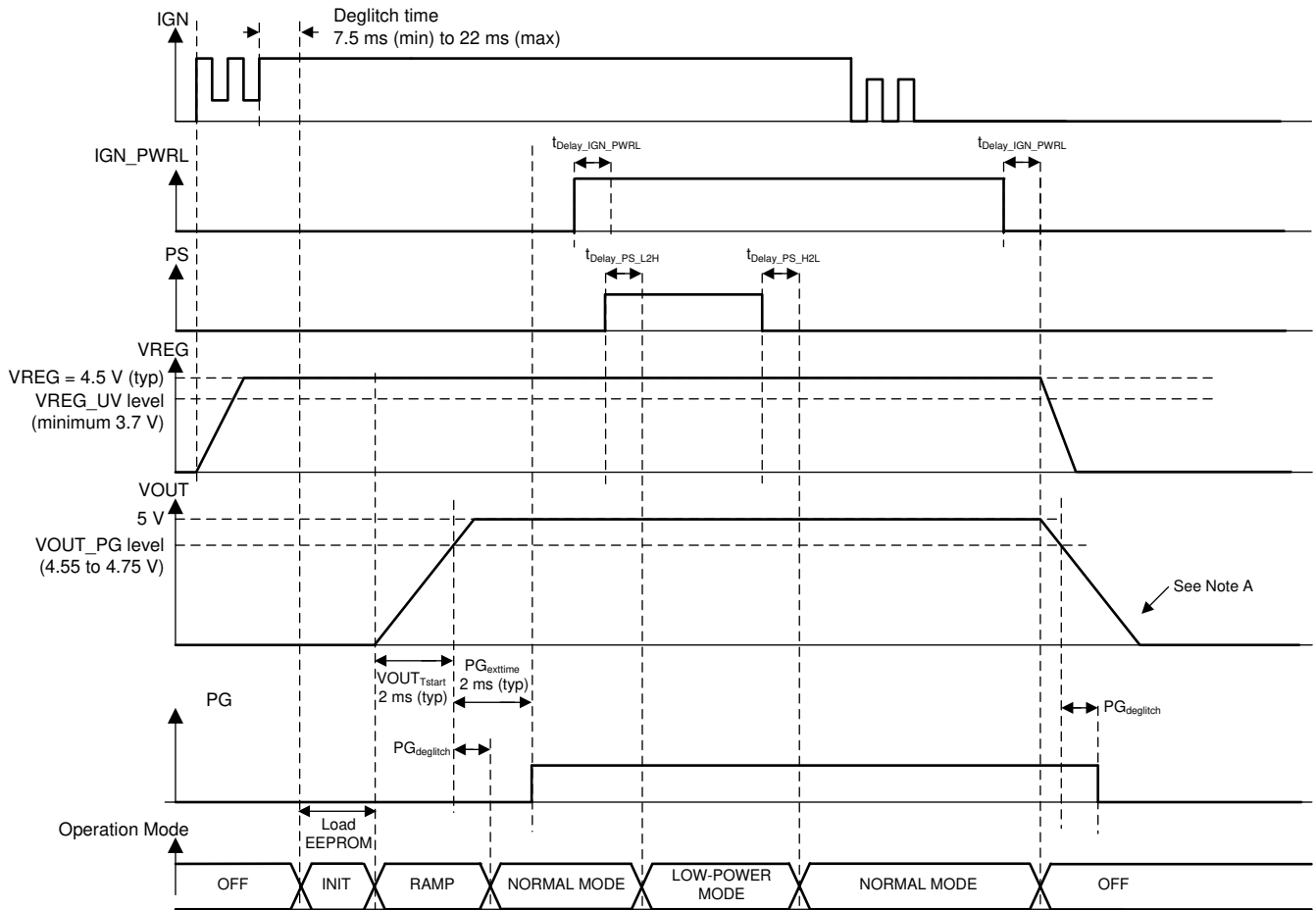

A. The actual ramp-down time of the output voltage depends on external load conditions.

Figure 8-3. Power-Up and Power-Down Sequence With Normal Mode and Low-Power Mode, With Usage of IGN_PWRL

Figure 8-4 shows a power-up and power-down sequence in low-Power mode with the IGN pin low. Figure 8-4 shows that after the device is powered on in the OFF state, the device is in low-power mode when the PS pin is high regardless of what was applied on the IGN and IGN_PWRL input pins.

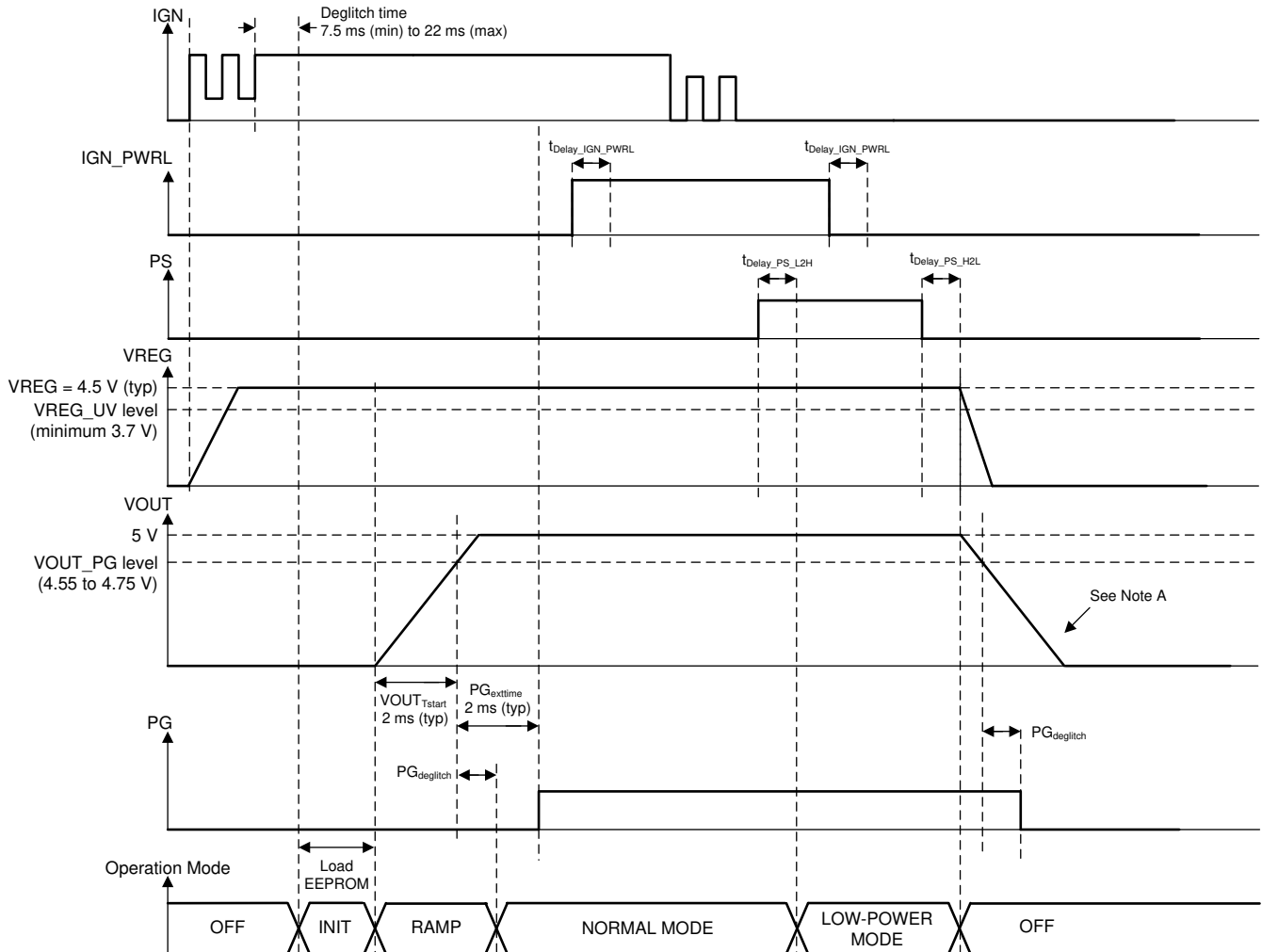

A. The actual ramp-down time of the output voltage depends on external load conditions.

Figure 8-4. Power-Up and Power-Down Sequence With Low-Power Mode When IGN and IGN_PWRL are Low (Essentially When the ECU is in Sleep or Standby Mode)

Figure 8-5 shows that when the device starts in the OFF state, the buck-boost converter always enters normal mode first, even when the PS pin was previously set high. The device can only enter low-power mode when the PG output pin is set high. Figure 8-5 also shows that the device does not start-up as long as the IGN pin is low.

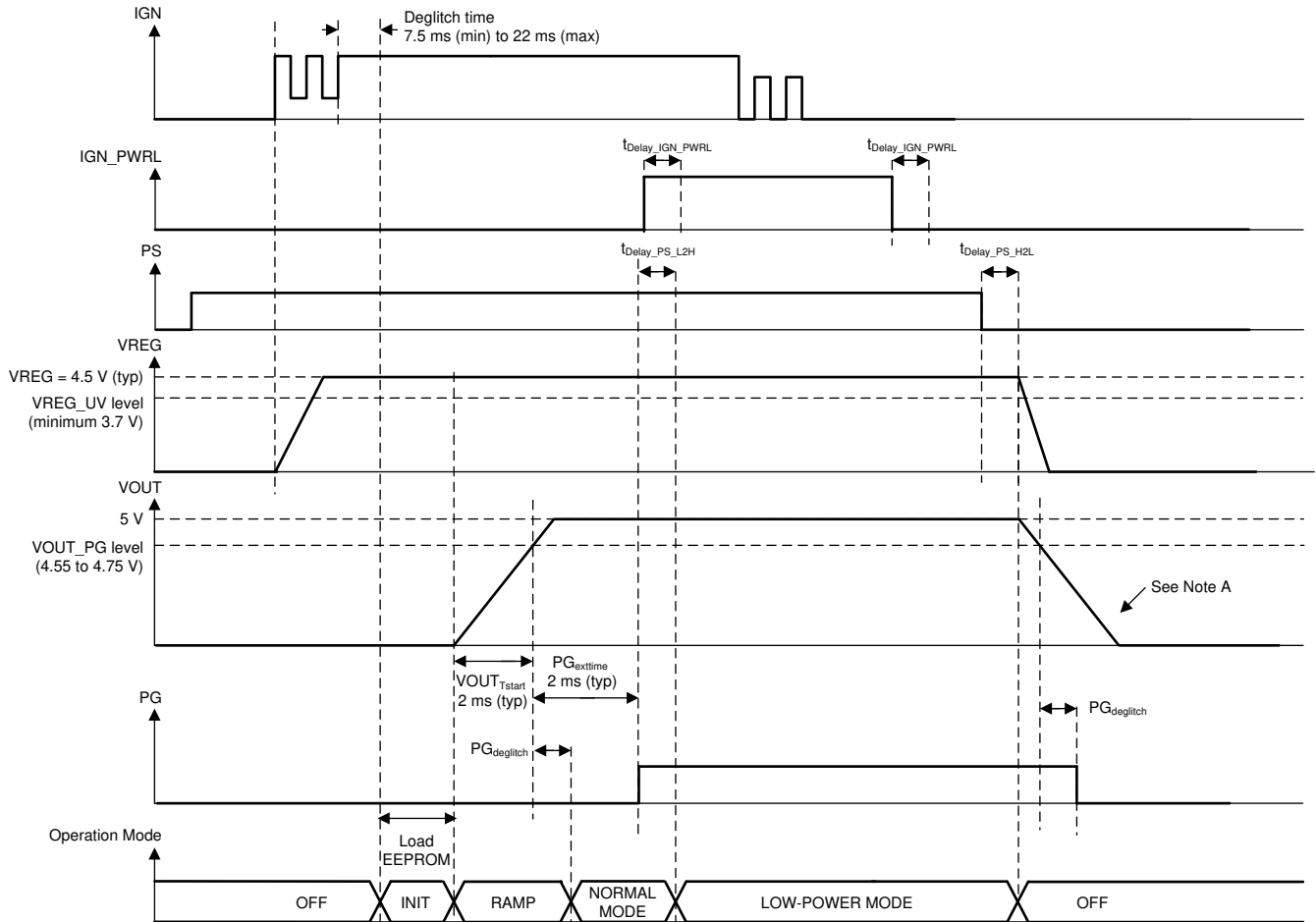

- A. The actual ramp-down time of the output voltage depends on external load conditions. The buck-boost converter always enters normal mode first after ramp up before it can enter low-power mode.

Figure 8-5. Power-Up Behavior With PS Pin Previously Set High

Figure 8-6 shows that the device only can start-up in the OFF state when the IGN pin is high. Setting the IGN_PWRL pin before the IGN pin is high does not start-up the device. Figure 8-6 also shows that the IGN_PWRL signal is only valid after the PG pin is high and the $PG_{Deglitch}$ time has elapsed.

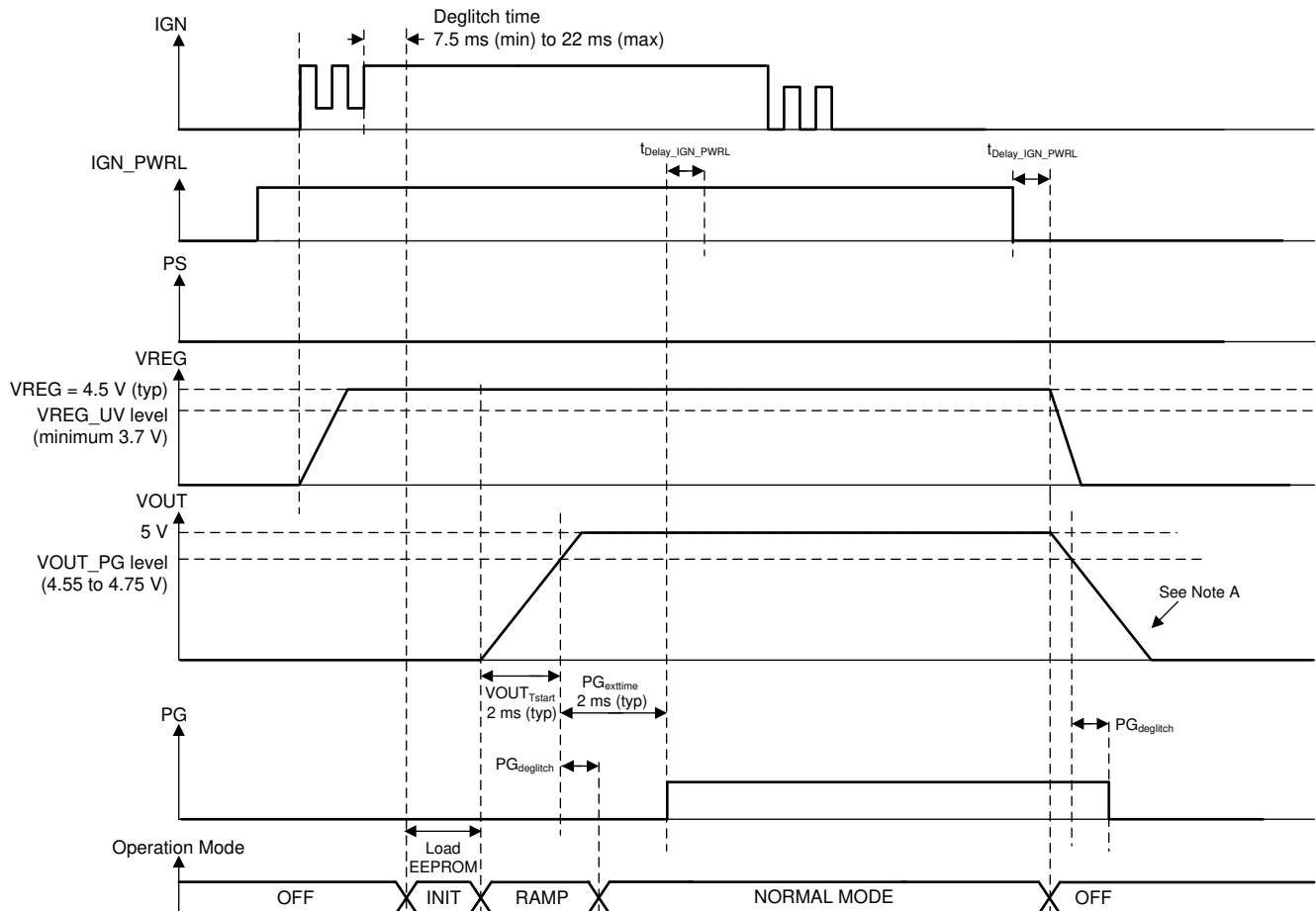

- A. The actual ramp-down time of the output voltage depends on external load conditions. The device does not start-up until the IGN pin is high. The IGN power-latch is only set after the PG pin is high.

Figure 8-6. Power-Up Behavior With IGN_PWRL Set High Prior to High IGN

8.4.4 Soft-Start Feature

On power up, the device has a soft-start feature which ramps the output of the regulator at a steady slew rate. The soft-start ramp time is 0.5 ms by default. When the device pulls the PG pin low because of a V_{OUT} undervoltage condition while the device is in normal mode, the device stays in normal mode and tries to get to the V_{OUT} level again without soft-start slew-ramp control.

8.4.5 Pulldown Resistor on VOUT

When the buck-boost regulator is disabled (in the OFF state, INIT state, and PRE_RAMP state), an internal active pulldown circuit (specified as $R_{pdV_{OUT}}$ in [Section 7.7](#)) pulls down the VOUT pin.

8.4.6 Output Voltage Selection

The configuration of the output voltage is selectable through the VOS_FB pin.

The fixed output voltage of the TPS55165-Q1 device is 5 V when the VOS_FB pin is connected to ground and is 12 V when the VOS_FB pin is connected to the VREG pin. For the TPS55165-Q1 device in the 5-V configuration (VOS_FB pin connected to ground), the UVLO threshold is set to less than 2 V. When the TPS55165-Q1 device is in the 12-V configuration (VOS_FB pin connected to the VREG pin), the UVLO threshold is set to less than 3.6 V. For the TPS55162-Q1 device, the UVLO threshold is also set to less than 3.6 V.

For the adjustable output voltage of the TPS55160-Q1 and TPS55162-Q1 devices, connect the VOS_FB pin to the external feedback network. The total resistance of this external feedback network must be less than 1 M Ω (essentially, this value must be similar to or less than the implemented total resistance of the implemented internal feedback network for the 12 V setting).

9 Application and Implementation

Note

Information in the following applications sections is not part of the TI component specification, and TI does not warrant its accuracy or completeness. TI's customers are responsible for determining suitability of components for their purposes, as well as validating and testing their design implementation to confirm system functionality.

9.1 Application Information

The TPS5516x-Q1 family of devices is a high-voltage synchronous buck-boost DC-DC converter with all four power MOSFETs integrated. Each device in the device family can produce a well-regulated output voltage from a widely-varying input voltage source such as an automotive car battery. If the input voltage is higher than the output voltage, the TPS5516x-Q1 device operates in step-down mode. If the input voltage is lower than the output, the device operates in step-up mode. If the input voltage is equal or close to the output voltage, the device operates between the step-down and step-up mode. The buck-boost overlap control ensures automatic and smooth transition between step-down and step-up (this is okay. Step-up and step-down modes were mentioned in the first page of the spec) modes with optimal efficiency. The output voltage of the TPS55165-Q1 device can be set to a fixed level of 5 V or 12 V. The output voltage of the TPS55160-Q1 and TPS55162-Q1 devices is programmable from 5.7 V to 9 V.

9.1.1 Application Circuits for Output Voltage Configurations

Figure 9-1 and Figure 9-2 show the application diagrams for the adjustable output configuration.

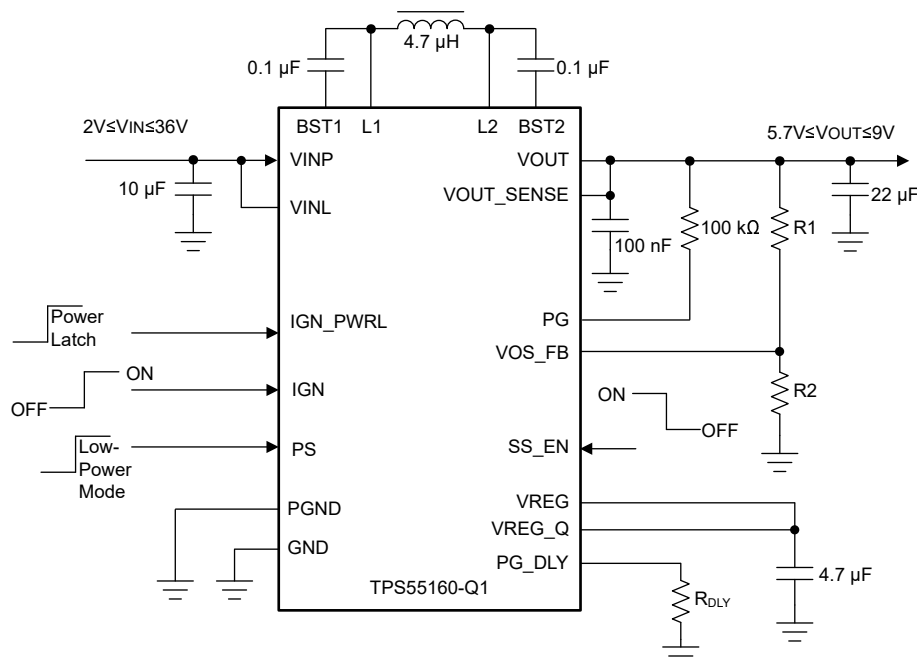

Figure 9-1. TPS55160-Q1 Application Diagram for Adjustable Output Voltage

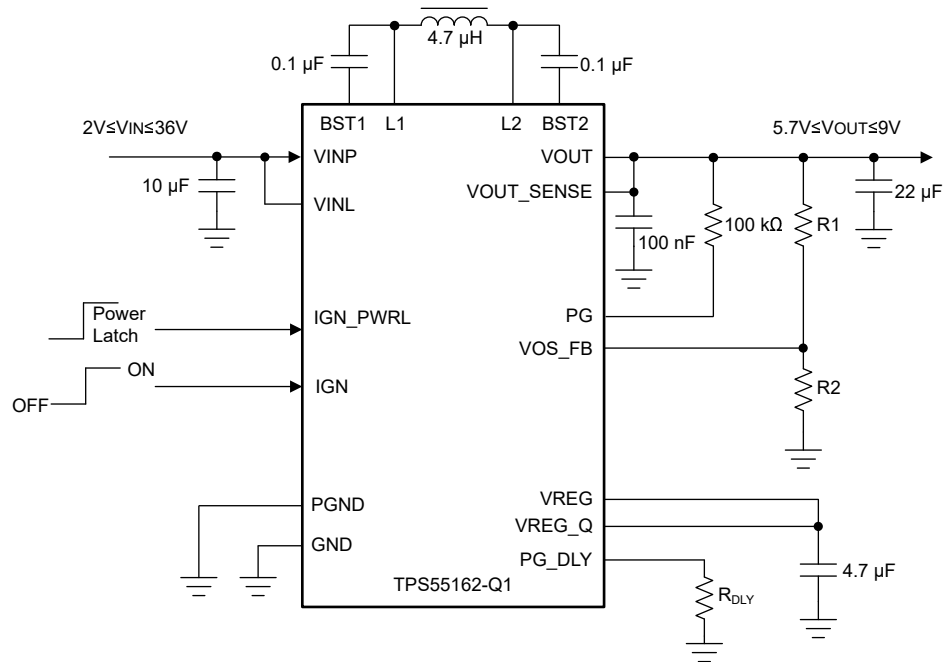

Figure 9-2. TPS55162-Q1 Application Diagram for Adjustable Output Voltage

Use [Equation 1](#) to calculate the output voltage.

$$V_{OUT} = \frac{R1 + R2}{R2} \times V_{FB} \quad (1)$$

where

- V_{FB} is 0.8 V (see [Section 7.7](#)).

Figure 9-3 shows the TPS55165-Q1 device in the 5-V configuration.

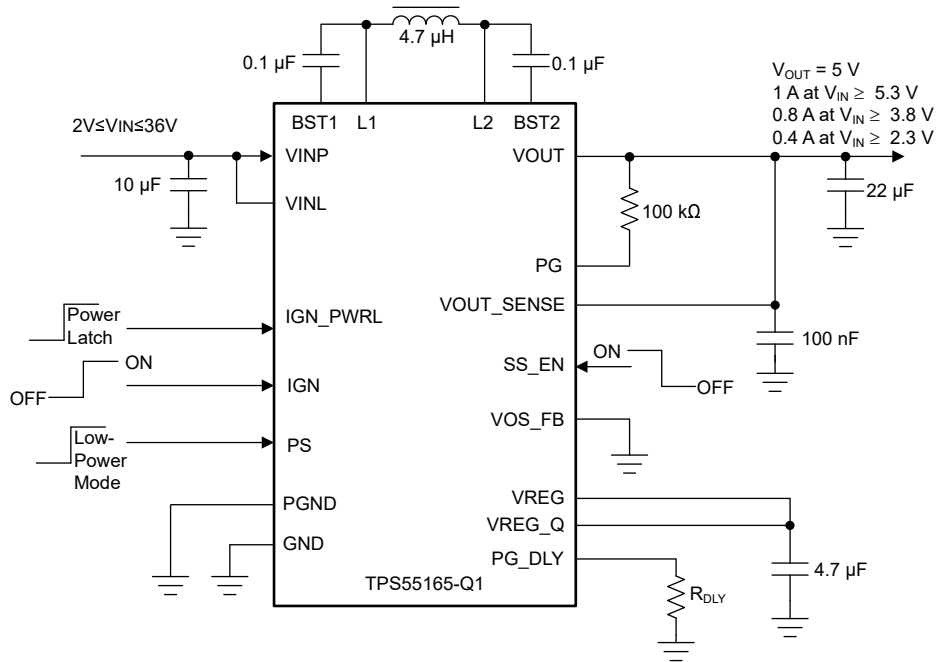

Figure 9-3. TPS55165-Q1 Application Diagram for 5-V Voltage

Figure 9-4 shows the TPS55165-Q1 device in the 12-V configuration.

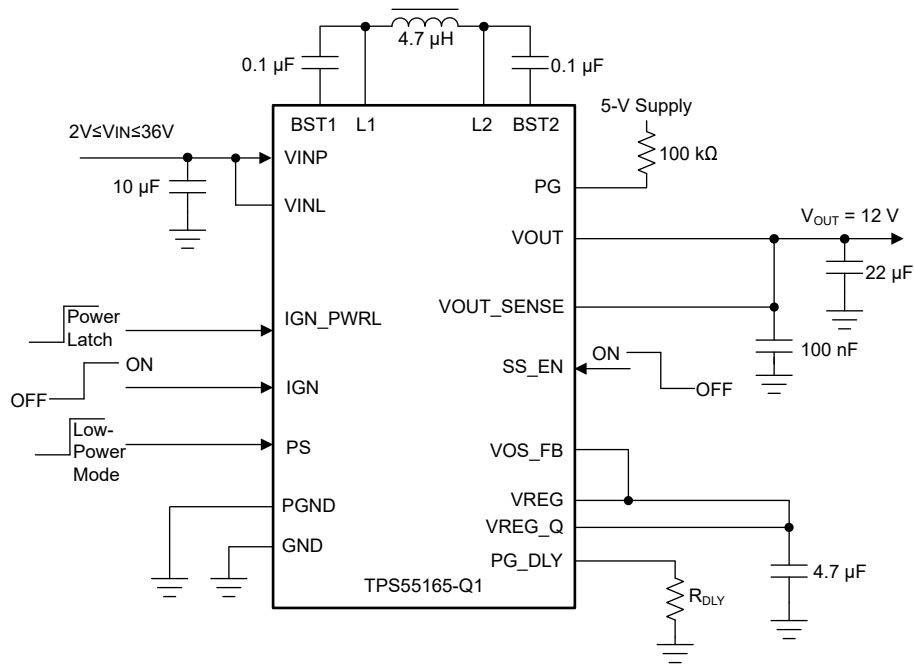

Figure 9-4. TPS55165-Q1 Application Diagram for 12-V Voltage

CAUTION

For TPS55165-Q1 in 12-V configuration (VOS_FB is shorted to VREG), the PG pin must be tied to an external 5-V supply through a pullup resistor. Tying the PG pin to a supply greater than 5.5 V could damage the device in the unlikely event of a shortage between the PG pin and the adjacent VOS_FB pin, which is tied to the VREG pin in the 12-V output configuration. The absolute-maximum voltage rating of the VREG pin is 5.5 V.

9.2 Typical Application

The TPS5516x-Q1 family of devices requires a minimum number of external components to implement a buck-boost converter. Figure 9-5 shows the typical schematic for the TPS55165-Q1 device in the 5-V configuration.

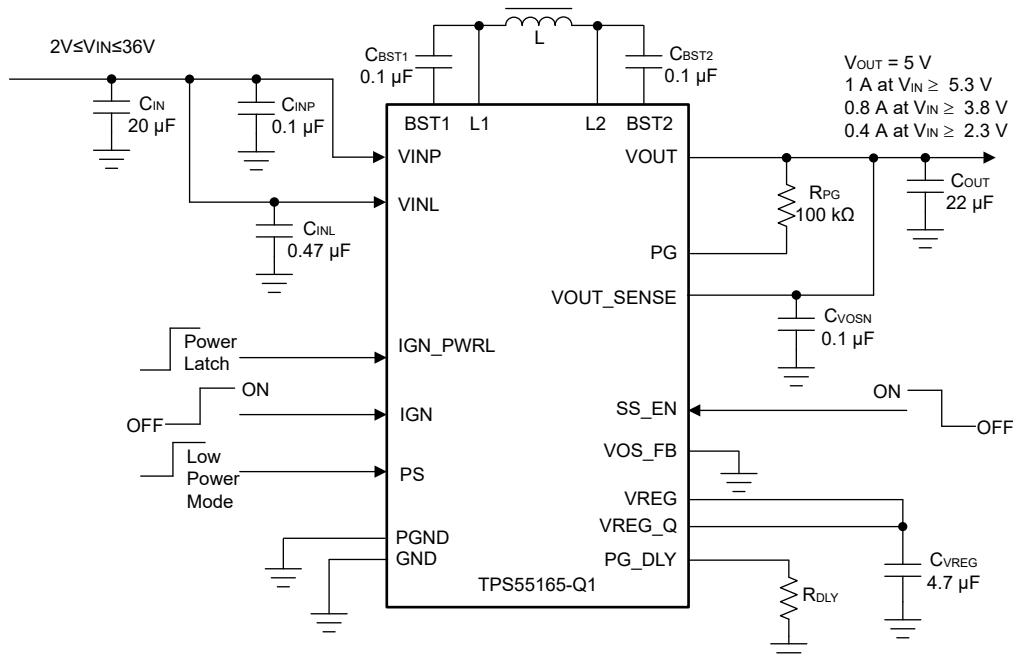

Figure 9-5. TPS55165-Q1 Buck-Boost Converter for Fixed 5-V Output

9.2.1 Design Requirements

Table 9-1 lists the design requirements for Figure 9-5.

Table 9-1. Design Requirements

PARAMETER	VALUE	
V_{IN_MIN}	The least input voltage after start-up. The I_{OUT_MAX} load current deratings listed in this table apply for $V_{IN} < 5.3$ V.	2 V
$V_{IN_startup}$	The minimum input voltage required for start-up	> 5.3 V
V_{IN_MAX}	The greatest input voltage after start-up	36 V
V_{OUT}	The output voltage	5 V
I_{OUT_MAX}	The maximum output current at $V_{IN} \geq 5.3$ V	1 A
	The maximum output current at 3.8 V $\leq V_{IN} < 5.3$ V	0.8 A
	The maximum output current at 2.3 V $\leq V_{IN} < 3.8$ V	0.4 A

9.2.2 Detailed Design Procedure

9.2.2.1 Power-Circuit Selections: C_{IN} , L , C_{OUT}

The TPS5516x-Q1 family of devices integrates not only the power switches but also the loop compensation network as well as many other control circuits which reduces the number of required external components. For the internal loop compensation to be effective, the selection of the external power circuits (power inductor and capacitor) must be confined. TI strongly recommends users selecting the component values as follows: 3.3- μ H to 6.2- μ H power inductor, 18- μ F to 47- μ F output capacitor, and 8.2- μ F or greater input capacitor. Because the TPS5516x-Q1 device switches at about 2 MHz, a shielded inductor and X5R-type or X7R-type ceramic capacitors should be used for the power circuit.

Considering the component tolerance, the following power component values were selected for this design example:

- $C_{IN} = 20 \mu\text{F}$
- $C_{OUT} = 22 \mu\text{F}$
- $L = 4.7 \mu\text{H}$

For the input capacitor (C_{IN}), the voltage rating should be greater than the maximum input voltage (V_{IN_MAX}). Therefore, two, 10- μF X7R capacitors rated for 50 V were selected for this design example. Adding a small, high-frequency decoupling ceramic capacitor (C_{VINP} with a value of 100 nF typical) in parallel with the input capacitor is recommended to better filter out the switching noises at the VINP pin. Adding another decoupling ceramic capacitor (C_{VINL} with a value of 470 nF typical) is also recommended for the VINL pin.

The output capacitor (C_{OUT}), receives a voltage of 5 V. Considering some voltage-rating margin, two 10- μF X7R capacitors rated for 10 V or greater and one, 2.2- μF X7R-type capacitor rated for 10 V or greater in parallel were selected for the output capacitor. Adding a small, high-frequency decoupling ceramic capacitor (C_{VOSN} with a value of 100 nF typical) in parallel with the output capacitor is recommended to better filter out the switching noises at the VOUT_SENSE pin.

The power inductor (L) should be a shielded type, and it should not saturate during operation. The inductor should also be able to support the power dissipation under the maximum load. Use the calculations in the following sections to find the required current capabilities for the inductor.

9.2.2.1.1 Inductor Current in Step-Down Mode

Use [Equation 2](#) to calculate inductor peak-ripple current in the step-down, or buck, mode (I_{pk_buck}).

$$I_{pk_buck} = \frac{1}{2} \times \frac{V_{OUT}}{L} \times \frac{1 - D_{buck}}{f_s} \quad (2)$$

where

- V_{OUT} is the output voltage.
- L is the value of the inductor.
- D_{buck} is the duty cycle (refer to [Equation 3](#)).
- f_s is the switching frequency.

$$D_{buck} = \frac{V_{OUT}}{V_{IN}} \quad (3)$$

The maximum peak-ripple current of the inductor (I_{pk}) occurs when the duty cycle is at the minimum value, specifically when the input voltage (V_{IN}) is at the maximum value which yields the value shown in [Equation 4](#).

$$D_{buck} = \frac{5 \text{ V}}{36 \text{ V}} = 0.139 \quad (4)$$

Substitute the values for f_s , L , and D_{buck} , in [Equation 2](#) to find the peak-ripple current as shown in [Equation 5](#).

$$I_{pk_buck} = \frac{1}{2} \times \frac{5 \text{ V}}{4.7 \mu\text{H}} \times \frac{1 - 0.139}{2 \text{ MHz}} = 0.229 \text{ A} \quad (5)$$

The power dissipations can be determined by the RMS current of the inductor. Use [Equation 6](#) to calculate the RMS current of the inductor in buck mode (I_{rms_buck}).

$$I_{rms_buck} = \sqrt{I_{OUT}^2 + \frac{1}{3} \times I_{pk_buck}^2} = \sqrt{1 \text{ A}^2 + \frac{1}{3} \times 0.458 \text{ A}^2} = 1.1 \text{ A} \quad (6)$$

Use [Equation 7](#) to calculate the approximate power dissipation of the inductor in buck-mode ($P_{loss_L_buck}$).

$$P_{loss_L_buck} = I_{rms_buck}^2 \times R_{dc} \quad (7)$$

9.2.2.1.2 Inductor Current in Step-Up Mode

Use [Equation 8](#) to calculate the inductor peak-ripple current in the step-up, or boost, mode (I_{pk_boost}).

$$I_{pk_boost} = \frac{1}{2} \times \frac{V_{IN}}{L} \times \frac{D_{boost}}{f_{sw}} \quad (8)$$

where

- D_{boost} is the duty cycle in boost mode (refer to [Equation 9](#)).

$$D_{boost} = \frac{V_{OUT} - V_{IN}}{V_{VOUT}} \quad (9)$$

In general, the maximum peak-ripple current occurs at 50% duty cycle. In this example, because of the power derating versus the input voltage, a few calculations can find that the maximum RMS current occurs when the input voltage is approximately 3.8 V, of which the load current is 0.8 A, according to [Table 9-1](#). [Equation 10](#) and [Equation 11](#) show the peak-ripple current under this condition.

$$D_{boost} = \frac{5\text{ V} - 3.8\text{ V}}{5\text{ V}} = 0.240 \quad (10)$$

$$I_{pk_boost} = \frac{1}{2} \times \frac{3.8\text{ V}}{4.7\text{ }\mu\text{H}} \times \frac{0.240}{2\text{ MHz}} = 0.049\text{ A} \quad (11)$$

The power dissipations can be determined by the RMS current of the inductor. Use [Equation 12](#) to calculate the RMS current of the inductor in buck mode (I_{rms_boost}).

$$I_{rms_boost} = \sqrt{\left(\frac{I_{OUT}}{1 - D_{boost}}\right)^2 + \frac{1}{3} \times I_{pk_boost}^2} = \sqrt{\left(\frac{0.8\text{ A}}{1 - 0.24}\right)^2 + \frac{1}{3} \times 0.049\text{ A}^2} = 1.053\text{ A} \quad (12)$$

Use [Equation 13](#) to calculate the approximate power dissipation of the inductor in boost-mode ($P_{loss_L_boost}$).

$$P_{loss_L_boost} = I_{rms_boost}^2 \times R_{dc} \quad (13)$$

9.2.2.1.3 Inductor Current in Buck-Boost Overlap Mode

When input voltage is very close to the output voltage, the device operates in buck-boost overlap mode, and the L1 and L2 pins are switched alternatively in consecutive cycles. The small voltage difference between the input and output voltage leads to a small amount of ripple current through the inductor. Therefore, the total inductor current is essentially the load current with small ripples superimposed onto it, and the RMS current is approximately the same as the load current, which is 1 A.

$$P_{loss_L_buckboost} = I_o^2 \times R_{dc} \quad (14)$$

9.2.2.1.4 Inductor Peak Current

Because the TPS5516x-Q1 device has internal peak current limit (I_{SW_limit}) of 4.5 A (maximum), this current should be considered when selecting the power inductor. Select the inductor of the saturation current (I_{SAT}) with a minimum value of 4.5 A so that the inductor never gets saturated. TI recommends using a shielded inductor.

For this design example, select an AEC-Q200 Grade 0, shielded inductor with the following characteristics:

- Is a surface-mount device (SMD)
- Has an inductance of 4.7 μH
- Supports a saturation current (I_{SAT}) of 4.8 A
- Is rated for an RMS current (I_{rms}) of 1.5 A or larger

- Is rated for a DC load (R_{dc}) of 0.04 Ω or smaller

9.2.2.2 Control-Circuit Selections

9.2.2.2.1 Bootstrap Capacitors

The bootstrap capacitors (C_{BST1} and C_{BST2}) supply the internal high-side MOSFET driver. TI recommends using a 0.1- μ F, X7R-type ceramic capacitor rated for 15 V or larger for the bootstrap capacitors.

9.2.2.2.2 VOUT-Sense Bypass Capacitor

To improve noise immunity, connect a 0.1- μ F, X7R-type ceramic capacitor rated for 25 V or greater to the VOUT pin.

9.2.2.2.3 VREG Bypass Capacitor

The VREG supplies the internal control circuit as well as the drivers for the integrated low-side driver. To improve noise immunity and stabilize the internal VREG regulator, TI recommends connecting a 4.7- μ F, X7R-type ceramic capacitor rated for 25 V or greater between the VREG and GND pins.

9.2.2.2.4 PG Pullup Resistor and Delay Time

The power-good indicator pin (PG) is an open-drain output pin. The PG pin requires an external pullup resistor to flag the power-good status. For this design example, select a 100-k Ω resistor to pull up the PG pin from the output rail.

The PG_DLY pin sets the delay time for the PG status to flip. Follow the instructions listed in the [Section 8.3.7](#) to program the delay.

9.2.3 Application Curves

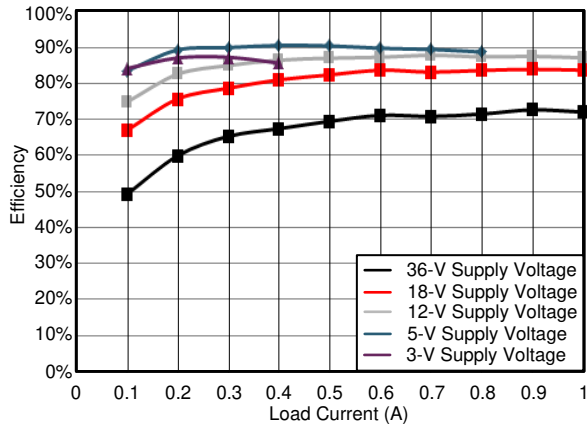

Figure 9-6. Efficiency vs Load

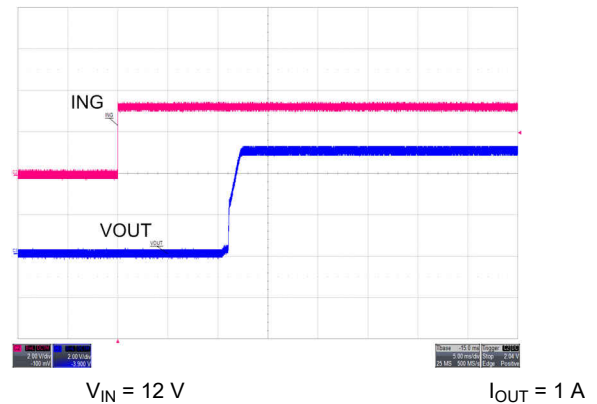

Figure 9-7. Start-Up Procedure

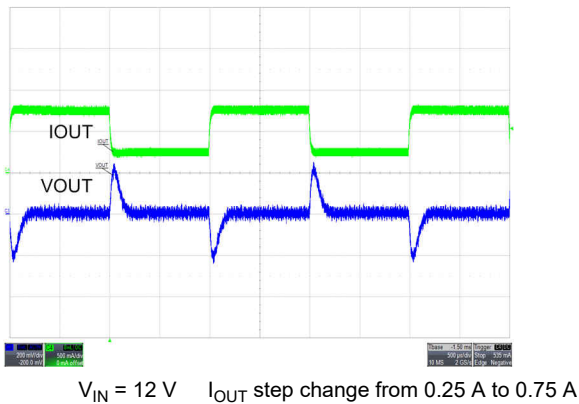

Figure 9-8. Step Load Response

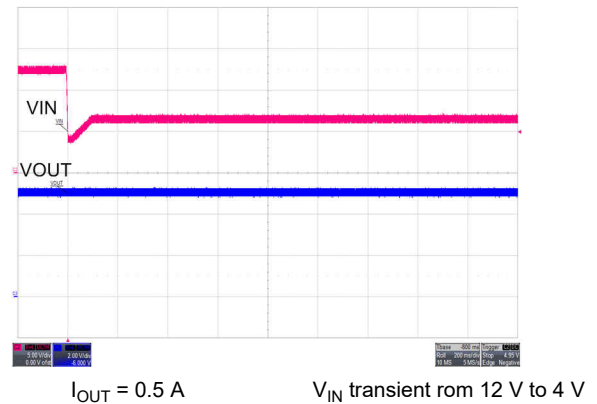

Figure 9-9. Battery-Voltage Cranking Response

10 Power Supply Recommendations

The TPS5516x-Q1 family of devices is a power-management device. The power supply for the device is any DC-voltage source within the specified input range. The supply should also be capable of supplying sufficient current based on the maximum inductor current in boost-mode operation. When connecting to the power supply and load, try to use short and solid wires. Twisting the pair of wires for the input and output helps minimize the line impedance and avoid adversary interference with the circuit operation.

11 Layout

11.1 Layout Guidelines

The layout of the printed-circuit board (PCB) is critical to achieve low EMI and stable power-supply operation as well as optimal efficiency. Make the high frequency current loops as small as possible, and follow these guidelines of good layout practices;

- The TPS5516x-Q1 family of devices is a high-frequency switching converter. Because the four switch MOSFETs are integrated, the device should be located at the center of the DC-DC power stage. Separate the power ground and analog ground such that the control circuit can be connected to the relatively quieter analog ground without being contaminated by the noisy power ground. Use the PGND pin, GND pin, and the device PowerPAD as the single-point connection between the analog and power grounds.
- Identify the high-frequency switched AC-current loops. In step-down mode, the AC current loop is along the path of the input capacitor (C_{IN}), L1 pin, internal buck-switch leg, and PGND pin, and closes at the input capacitor. In step-up mode, the AC current loop is along the path of the output capacitor (C_{OUT}), L2 pin, internal boost-switch leg, and PGND pin, and closes at the output capacitor. These two AC-current loops are both involved in buck-boost overlap mode.
- Optimize component placement and orientation before routing any traces. Place the input and output filter capacitors, the device, and the power inductor close together such that the AC-current loops are short, direct, and the spatial areas enclosed by the loops are minimized. Make the power flow in a straight path rather than a zigzag path on the board.
- Place the high frequency decoupling ceramic capacitors for the input and output as close as possible to the device with the main input and output ceramic capacitors placed next to the high-frequency capacitors. This placement helps confine the high switching noises within a very small area around the device.
- Place the VREG decoupling capacitor close to the VREG pin because it serves as the supply to the internal low-side MOSFETs drivers. Because the VREG pin receives power from the output rail, the ground lead of the VREG decoupling capacitor should connect directly to the C_{OUT} ground to improve device noise immunity.

Note

The VREG_Q pin must always connect to the VREG pin. Both pins should have a Kelvin connection to the decoupling capacitor.

- Place the bootstrap capacitors (C_{BST1} and C_{BST2}) close to the device with short and direct traces to connect to the corresponding device pins because these capacitors serve as the supplies to the internal high-side MOSFETs drivers
- Place the VOUT_SENSE decoupling capacitor (C_{VOSN}) close to the device. Give the placement of this capacitor priority over the main output capacitors.
- For TPS55160-Q1 or TPS55162-Q1, place the sense-resistor divider for the output voltage close to the device.
- Use eight to nine via holes with a 0.3 mm diameter in the device PowerPAD to help dissipate heat through the layers of the ground plane. Additional vias holes around the device PowerPAD can further enhance heat dissipation.
- Use at least ten via holes with a 0.3 mm diameter around the input and output capacitors that are connected to ground-plane layers to minimize the PCB impedance for power current flows.

11.2 Layout Example

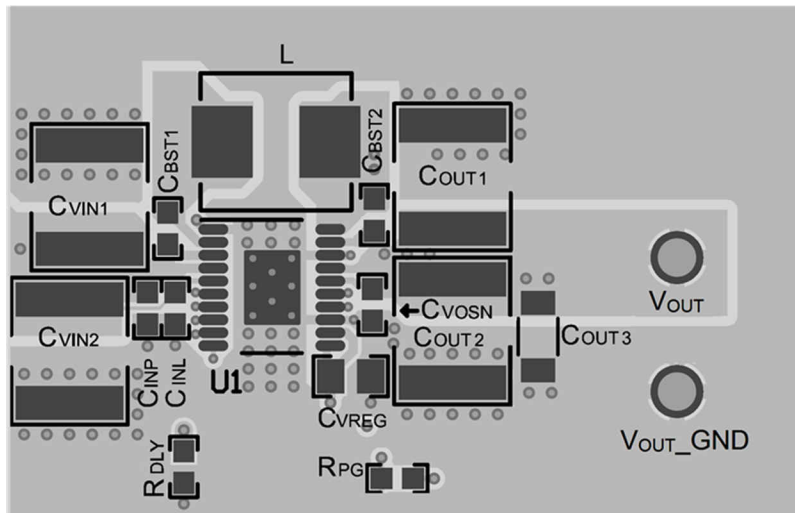

Figure 11-1. Example Circuit Layout

12 Device and Documentation Support

12.1 Device Support

12.1.1 Development Support

For development support, refer to:

[TPS55160-Q1 PSpice Transient Model](#)

12.2 Documentation Support

12.2.1 Related Documentation

For related documentation see the following:

Texas Instruments, [TPS5516xQ1-EVM Evaluation Module for 1-A Single- Inductor Buck-Boost-Converter user's guide](#)

12.3 Receiving Notification of Documentation Updates

To receive notification of documentation updates, navigate to the device product folder on [ti.com](#). Click on *Subscribe to updates* to register and receive a weekly digest of any product information that has changed. For change details, review the revision history included in any revised document.

12.4 Support Resources

[TI E2E™ support forums](#) are an engineer's go-to source for fast, verified answers and design help — straight from the experts. Search existing answers or ask your own question to get the quick design help you need.

Linked content is provided "AS IS" by the respective contributors. They do not constitute TI specifications and do not necessarily reflect TI's views; see TI's [Terms of Use](#).

12.5 Trademarks

PowerPAD™ is a trademark of Texas Instruments.

TI E2E™ is a trademark of Texas Instruments.

All trademarks are the property of their respective owners.

12.6 Electrostatic Discharge Caution



This integrated circuit can be damaged by ESD. Texas Instruments recommends that all integrated circuits be handled with appropriate precautions. Failure to observe proper handling and installation procedures can cause damage.

ESD damage can range from subtle performance degradation to complete device failure. Precision integrated circuits may be more susceptible to damage because very small parametric changes could cause the device not to meet its published specifications.

12.7 Glossary

[TI Glossary](#) This glossary lists and explains terms, acronyms, and definitions.

13 Mechanical, Packaging, and Orderable Information

The following pages include mechanical, packaging, and orderable information. This information is the most current data available for the designated devices. This data is subject to change without notice and revision of this document. For browser-based versions of this data sheet, refer to the left-hand navigation.

PACKAGING INFORMATION

Orderable part number	Status (1)	Material type (2)	Package Pins	Package qty Carrier	RoHS (3)	Lead finish/ Ball material (4)	MSL rating/ Peak reflow (5)	Op temp (°C)	Part marking (6)
TPS55160QPWPRQ1	Active	Production	HTSSOP (PWP) 20	2000 LARGE T&R	Yes	NIPDAU	Level-3-260C-168 HR	-40 to 125	TPS55160
TPS55160QPWPRQ1.A	Active	Production	HTSSOP (PWP) 20	2000 LARGE T&R	Yes	NIPDAU	Level-3-260C-168 HR	-40 to 125	TPS55160
TPS55160QPWPTQ1	Active	Production	HTSSOP (PWP) 20	250 SMALL T&R	Yes	NIPDAU	Level-3-260C-168 HR	-40 to 125	TPS55160
TPS55160QPWPTQ1.A	Active	Production	HTSSOP (PWP) 20	250 SMALL T&R	Yes	NIPDAU	Level-3-260C-168 HR	-40 to 125	TPS55160
TPS55162QPWPRQ1	Active	Production	HTSSOP (PWP) 20	2000 LARGE T&R	Yes	NIPDAU	Level-3-260C-168 HR	-40 to 125	TPS55162
TPS55162QPWPRQ1.A	Active	Production	HTSSOP (PWP) 20	2000 LARGE T&R	Yes	NIPDAU	Level-3-260C-168 HR	-40 to 125	TPS55162
TPS55162QPWPTQ1	Active	Production	HTSSOP (PWP) 20	250 SMALL T&R	Yes	NIPDAU	Level-3-260C-168 HR	-40 to 125	TPS55162
TPS55162QPWPTQ1.A	Active	Production	HTSSOP (PWP) 20	250 SMALL T&R	Yes	NIPDAU	Level-3-260C-168 HR	-40 to 125	TPS55162
TPS55165QPWPRQ1	Active	Production	HTSSOP (PWP) 20	2000 LARGE T&R	Yes	NIPDAU	Level-3-260C-168 HR	-40 to 125	TPS55165
TPS55165QPWPRQ1.A	Active	Production	HTSSOP (PWP) 20	2000 LARGE T&R	Yes	NIPDAU	Level-3-260C-168 HR	-40 to 125	TPS55165
TPS55165QPWPTQ1	Active	Production	HTSSOP (PWP) 20	250 SMALL T&R	Yes	NIPDAU	Level-3-260C-168 HR	-40 to 125	TPS55165
TPS55165QPWPTQ1.A	Active	Production	HTSSOP (PWP) 20	250 SMALL T&R	Yes	NIPDAU	Level-3-260C-168 HR	-40 to 125	TPS55165

(1) **Status:** For more details on status, see our [product life cycle](#).

(2) **Material type:** When designated, preproduction parts are prototypes/experimental devices, and are not yet approved or released for full production. Testing and final process, including without limitation quality assurance, reliability performance testing, and/or process qualification, may not yet be complete, and this item is subject to further changes or possible discontinuation. If available for ordering, purchases will be subject to an additional waiver at checkout, and are intended for early internal evaluation purposes only. These items are sold without warranties of any kind.

(3) **RoHS values:** Yes, No, RoHS Exempt. See the [TI RoHS Statement](#) for additional information and value definition.

(4) **Lead finish/Ball material:** Parts may have multiple material finish options. Finish options are separated by a vertical ruled line. Lead finish/Ball material values may wrap to two lines if the finish value exceeds the maximum column width.

(5) **MSL rating/Peak reflow:** The moisture sensitivity level ratings and peak solder (reflow) temperatures. In the event that a part has multiple moisture sensitivity ratings, only the lowest level per JEDEC standards is shown. Refer to the shipping label for the actual reflow temperature that will be used to mount the part to the printed circuit board.

(6) **Part marking:** There may be an additional marking, which relates to the logo, the lot trace code information, or the environmental category of the part.

Multiple part markings will be inside parentheses. Only one part marking contained in parentheses and separated by a "-" will appear on a part. If a line is indented then it is a continuation of the previous line and the two combined represent the entire part marking for that device.

Important Information and Disclaimer: The information provided on this page represents TI's knowledge and belief as of the date that it is provided. TI bases its knowledge and belief on information provided by third parties, and makes no representation or warranty as to the accuracy of such information. Efforts are underway to better integrate information from third parties. TI has taken and continues to take reasonable steps to provide representative and accurate information but may not have conducted destructive testing or chemical analysis on incoming materials and chemicals. TI and TI suppliers consider certain information to be proprietary, and thus CAS numbers and other limited information may not be available for release.

In no event shall TI's liability arising out of such information exceed the total purchase price of the TI part(s) at issue in this document sold by TI to Customer on an annual basis.

TAPE AND REEL INFORMATION

QUADRANT ASSIGNMENTS FOR PIN 1 ORIENTATION IN TAPE

*All dimensions are nominal

Device	Package Type	Package Drawing	Pins	SPQ	Reel Diameter (mm)	Reel Width W1 (mm)	A0 (mm)	B0 (mm)	K0 (mm)	P1 (mm)	W (mm)	Pin1 Quadrant
TPS55160QPWPRQ1	HTSSOP	PWP	20	2000	330.0	16.4	6.95	7.1	1.6	8.0	16.0	Q1
TPS55162QPWPRQ1	HTSSOP	PWP	20	2000	330.0	16.4	6.95	7.1	1.6	8.0	16.0	Q1
TPS55165QPWPRQ1	HTSSOP	PWP	20	2000	330.0	16.4	6.95	7.1	1.6	8.0	16.0	Q1

TAPE AND REEL BOX DIMENSIONS

*All dimensions are nominal

Device	Package Type	Package Drawing	Pins	SPQ	Length (mm)	Width (mm)	Height (mm)
TPS55160QPWPRQ1	HTSSOP	PWP	20	2000	350.0	350.0	43.0
TPS55162QPWPRQ1	HTSSOP	PWP	20	2000	350.0	350.0	43.0
TPS55165QPWPRQ1	HTSSOP	PWP	20	2000	350.0	350.0	43.0

GENERIC PACKAGE VIEW

PWP 20

HTSSOP - 1.2 mm max height

6.5 x 4.4, 0.65 mm pitch

SMALL OUTLINE PACKAGE

This image is a representation of the package family, actual package may vary.
Refer to the product data sheet for package details.

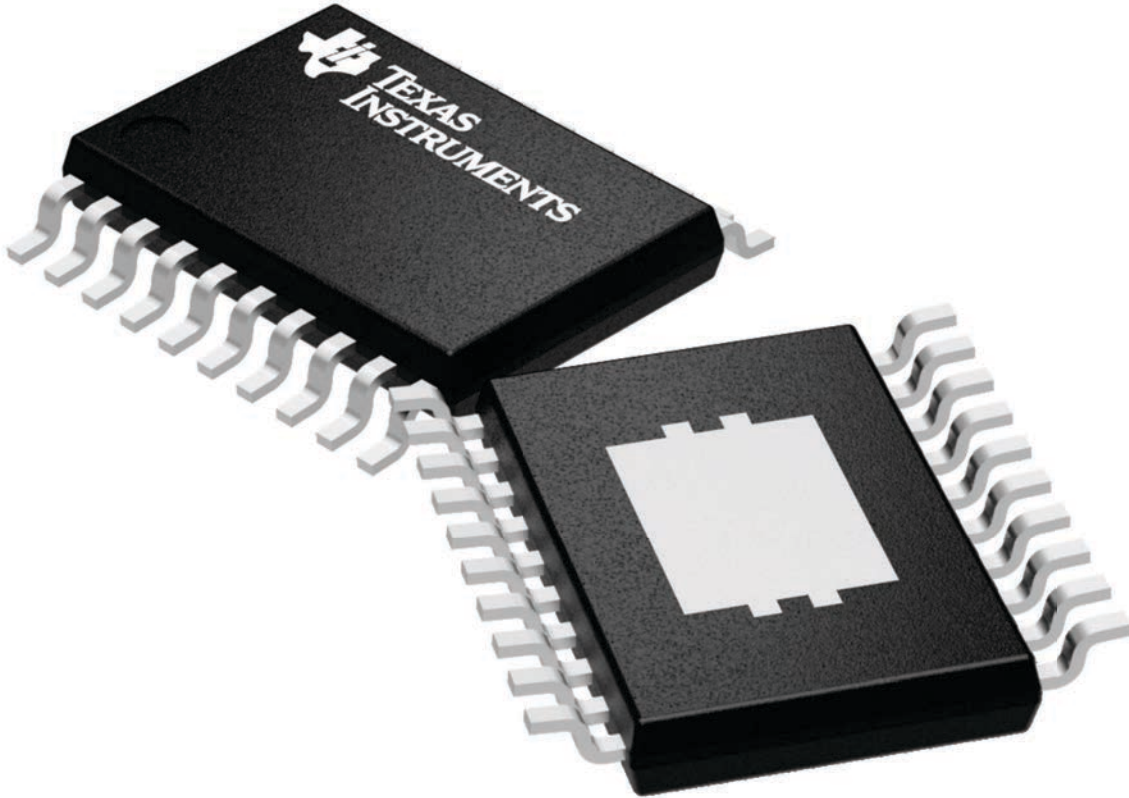

4224669/A

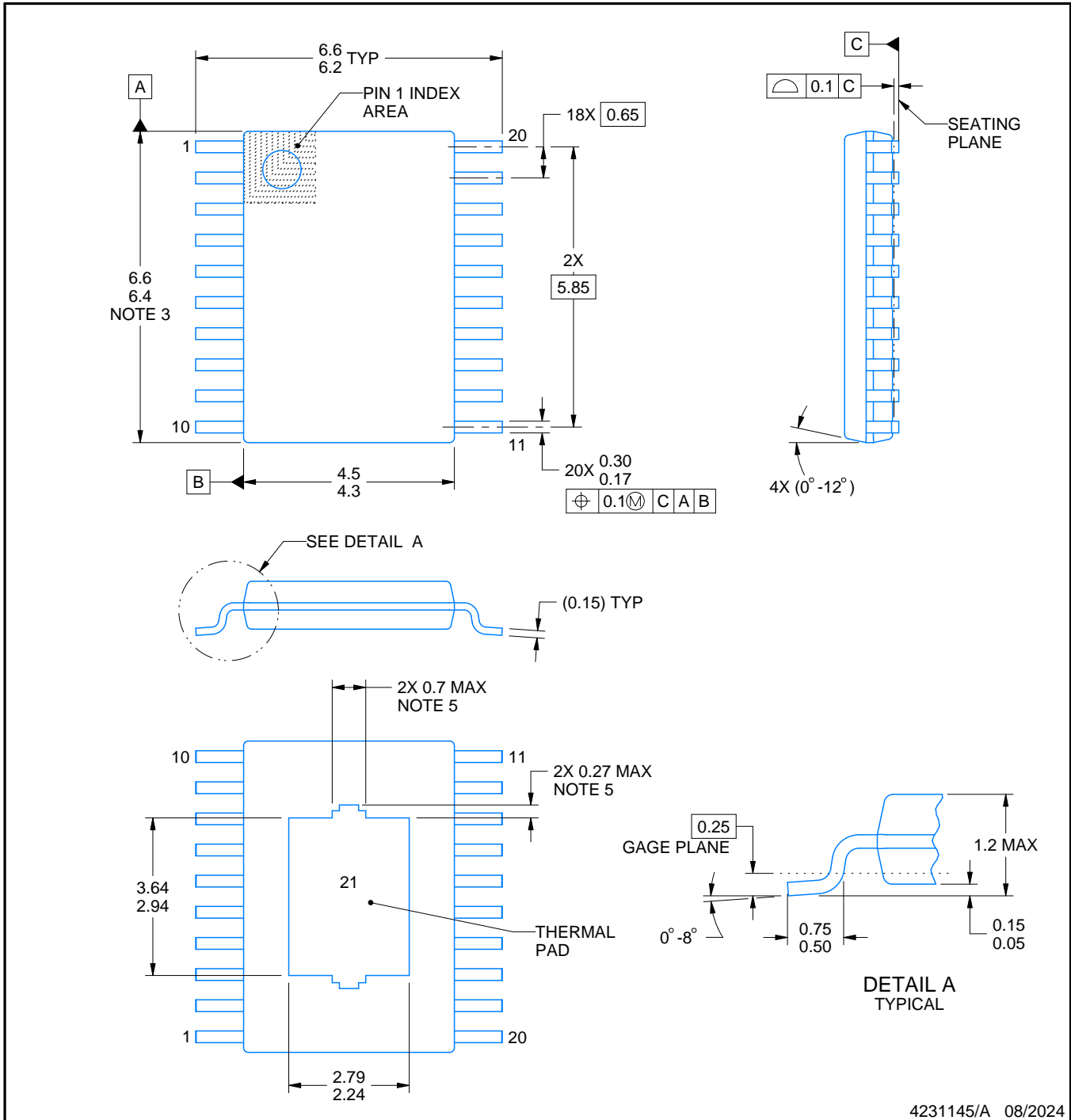
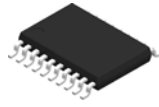

4231145/A 08/2024

PowerPAD is a trademark of Texas Instruments.

NOTES:

1. All linear dimensions are in millimeters. Any dimensions in parenthesis are for reference only. Dimensioning and tolerancing per ASME Y14.5M.
2. This drawing is subject to change without notice.
3. This dimension does not include mold flash, protrusions, or gate burrs. Mold flash, protrusions, or gate burrs shall not exceed 0.15 mm per side.
4. Reference JEDEC registration MO-153.
5. Features may differ or may not be present.

EXAMPLE BOARD LAYOUT

PWP0020W

PowerPAD™ TSSOP - 1.2 mm max height

SMALL OUTLINE PACKAGE

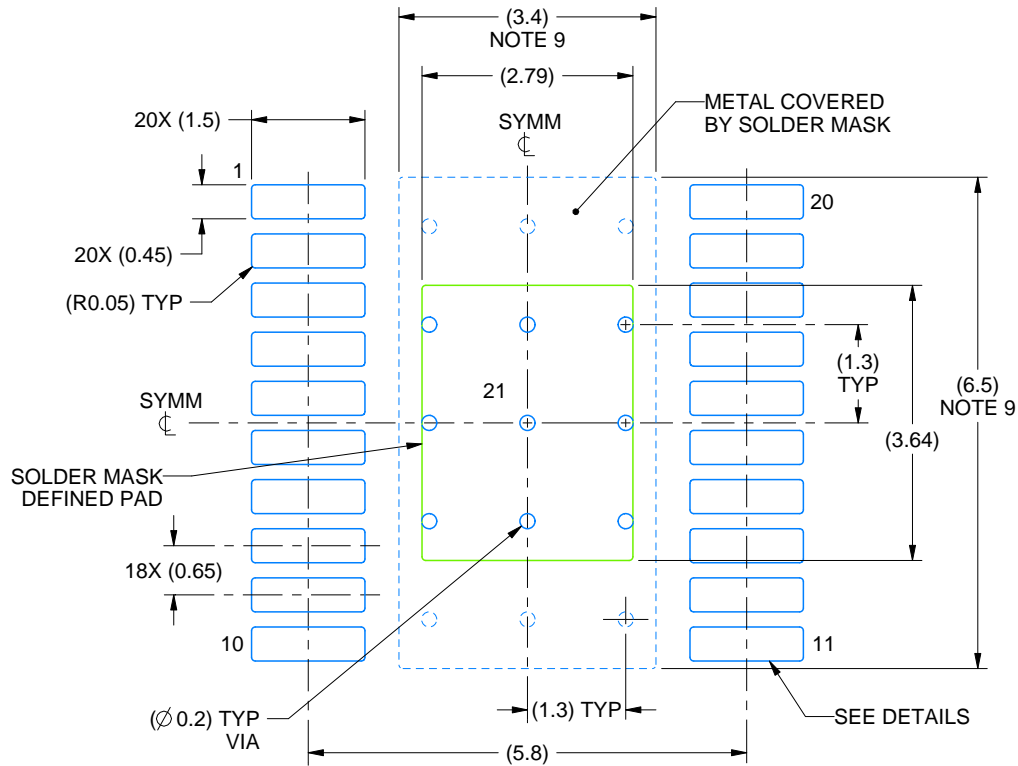

LAND PATTERN EXAMPLE
EXPOSED METAL SHOWN
SCALE: 10X

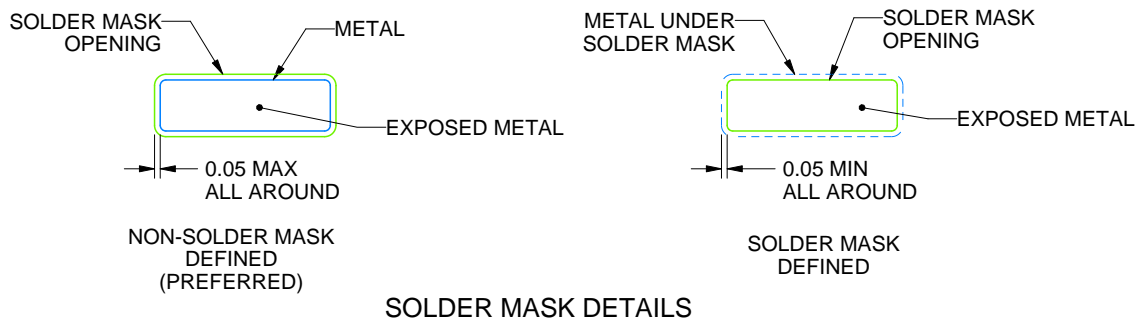

SOLDER MASK DETAILS

4231145/A 08/2024

NOTES: (continued)

6. Publication IPC-7351 may have alternate designs.
7. Solder mask tolerances between and around signal pads can vary based on board fabrication site.
8. This package is designed to be soldered to a thermal pad on the board. For more information, see Texas Instruments literature numbers SLMA002 (www.ti.com/lit/slma002) and SLMA004 (www.ti.com/lit/slma004).
9. Size of metal pad may vary due to creepage requirement.
10. Vias are optional depending on application, refer to device data sheet. It is recommended that vias under paste be filled, plugged or tented.

EXAMPLE STENCIL DESIGN

PWP0020W

PowerPAD™ TSSOP - 1.2 mm max height

SMALL OUTLINE PACKAGE

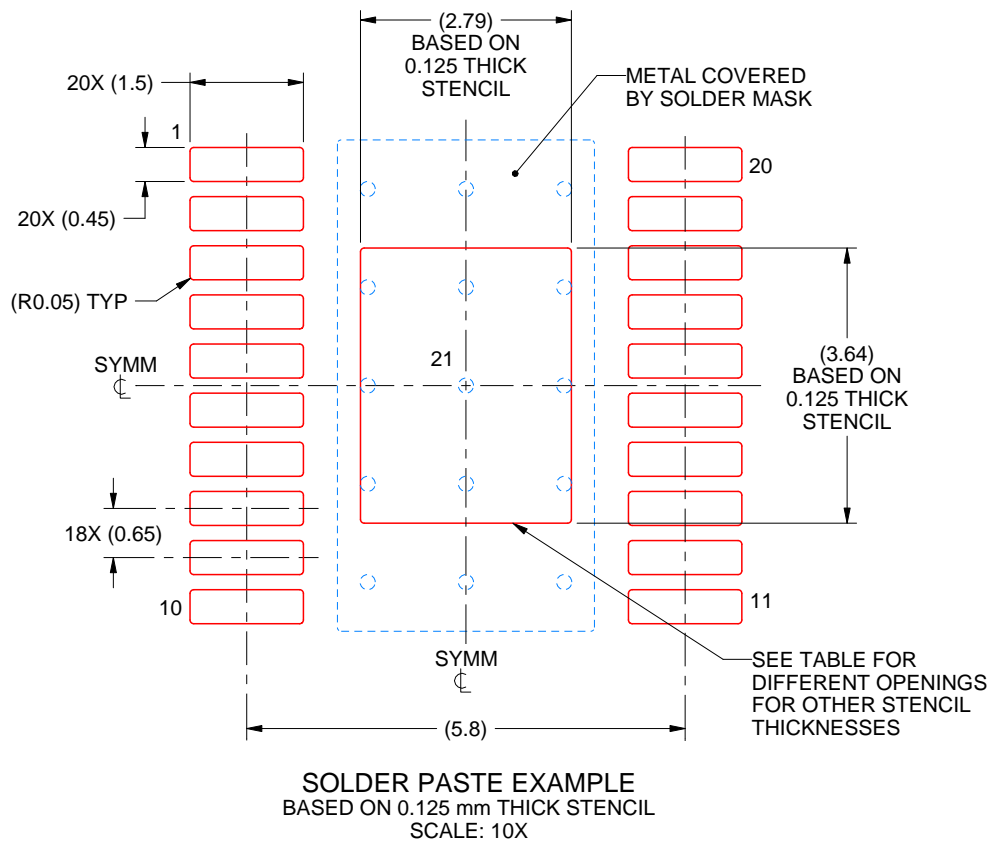

STENCIL THICKNESS	SOLDER STENCIL OPENING
0.1	3.12 X 4.07
0.125	2.79 X 3.64 (SHOWN)
0.15	2.55 X 3.32
0.175	2.36 X 3.08

4231145/A 08/2024

NOTES: (continued)

11. Laser cutting apertures with trapezoidal walls and rounded corners may offer better paste release. IPC-7525 may have alternate design recommendations.
12. Board assembly site may have different recommendations for stencil design.

IMPORTANT NOTICE AND DISCLAIMER

TI PROVIDES TECHNICAL AND RELIABILITY DATA (INCLUDING DATASHEETS), DESIGN RESOURCES (INCLUDING REFERENCE DESIGNS), APPLICATION OR OTHER DESIGN ADVICE, WEB TOOLS, SAFETY INFORMATION, AND OTHER RESOURCES "AS IS" AND WITH ALL FAULTS, AND DISCLAIMS ALL WARRANTIES, EXPRESS AND IMPLIED, INCLUDING WITHOUT LIMITATION ANY IMPLIED WARRANTIES OF MERCHANTABILITY, FITNESS FOR A PARTICULAR PURPOSE OR NON-INFRINGEMENT OF THIRD PARTY INTELLECTUAL PROPERTY RIGHTS.

These resources are intended for skilled developers designing with TI products. You are solely responsible for (1) selecting the appropriate TI products for your application, (2) designing, validating and testing your application, and (3) ensuring your application meets applicable standards, and any other safety, security, regulatory or other requirements.

These resources are subject to change without notice. TI grants you permission to use these resources only for development of an application that uses the TI products described in the resource. Other reproduction and display of these resources is prohibited. No license is granted to any other TI intellectual property right or to any third party intellectual property right. TI disclaims responsibility for, and you fully indemnify TI and its representatives against any claims, damages, costs, losses, and liabilities arising out of your use of these resources.

TI's products are provided subject to [TI's Terms of Sale](#), [TI's General Quality Guidelines](#), or other applicable terms available either on [ti.com](#) or provided in conjunction with such TI products. TI's provision of these resources does not expand or otherwise alter TI's applicable warranties or warranty disclaimers for TI products. Unless TI explicitly designates a product as custom or customer-specified, TI products are standard, catalog, general purpose devices.

TI objects to and rejects any additional or different terms you may propose.

Copyright © 2025, Texas Instruments Incorporated

Last updated 10/2025