

SN74LVCC3245A-EP OCTAL BUS TRANSCEIVER WITH ADJUSTABLE OUTPUT VOLTAGE AND 3-STATE OUTPUTS

SCAS773A – JUNE 2004 – REVISED MARCH 2005

- **Controlled Baseline**
 - One Assembly/Test Site, One Fabrication Site
- **Enhanced Diminishing Manufacturing Sources (DMS) Support**
- **Enhanced Product-Change Notification**
- **Qualification Pedigree†**
- **Bidirectional Voltage Translator**
- **2.3 V to 3.6 V on A Port and 3 V to 5.5 V on B Port**
- **Control Inputs V_{IH}/V_{IL} Levels Are Referenced to V_{CCA} Voltage**
- **Latch-Up Performance Exceeds 250 mA Per JESD 17**
- **ESD Protection Exceeds JESD 22**
 - 2000-V Human-Body Model (A114-A)
 - 200-V Machine Model (A115-A)
 - 1000-V Charged-Device Model (C101)

† Component qualification in accordance with JEDEC and industry standards to ensure reliable operation over an extended temperature range. This includes, but is not limited to, Highly Accelerated Stress Test (HAST) or biased 85/85, temperature cycle, autoclave or unbiased HAST, electromigration, bond intermetallic life, and mold compound life. Such qualification testing should not be viewed as justifying use of this component beyond specified performance and environmental limits.

DB, DW, OR PW PACKAGE
(TOP VIEW)

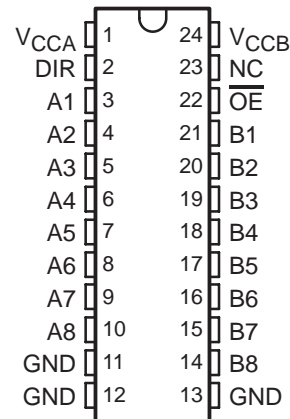

NC – No internal connection

description/ordering information

This 8-bit (octal) noninverting bus transceiver contains two separate supply rails. The B port is designed to track V_{CCB} , which accepts voltages from 3 V to 5.5 V, and the A port is designed to track V_{CCA} , which operates at 2.3 V to 3.6 V. This allows for translation from a 3.3-V to a 5-V system environment and vice versa, from a 2.5-V to a 3.3-V system environment and vice versa.

The SN74LVCC3245A is designed for asynchronous communication between data buses. The device transmits data from the A bus to the B bus or from the B bus to the A bus, depending on the logic level at the direction-control (DIR) input. The output-enable (\overline{OE}) input can be used to disable the device so the buses are isolated. The control circuitry (DIR, \overline{OE}) is powered by V_{CCA} .

ORDERING INFORMATION

T _A	PACKAGE†		ORDERABLE PART NUMBER	TOP-SIDE MARKING
–40°C to 85°C	SOIC – DW	Reel of 2000	CLVCC3245AIDWREP	LVCC3245A
	SSOP – DB	Reel of 2000	CLVCC3245AIDBREP	LH245AEP
	TSSOP – PW	Reel of 2000	CLVCC3245AIPWREP	LH245AEP

† Package drawings, standard packing quantities, thermal data, symbolization, and PCB design guidelines are available at www.ti.com/sc/package.



Please be aware that an important notice concerning availability, standard warranty, and use in critical applications of Texas Instruments semiconductor products and disclaimers thereto appears at the end of this data sheet.

PRODUCTION DATA information is current as of publication date. Products conform to specifications per the terms of Texas Instruments standard warranty. Production processing does not necessarily include testing of all parameters.

**TEXAS
INSTRUMENTS**

POST OFFICE BOX 655303 • DALLAS, TEXAS 75265

Copyright © 2005, Texas Instruments Incorporated

SN74LVCC3245A-EP

OCTAL BUS TRANSCEIVER WITH ADJUSTABLE OUTPUT VOLTAGE AND 3-STATE OUTPUTS

SCAS773A – JUNE 2004 – REVISED MARCH 2005

FUNCTION TABLE
(each transceiver)

INPUTS		OPERATION
\overline{OE}	DIR	
L	L	B data to A bus
L	H	A data to B bus
H	X	Isolation

logic diagram (positive logic)

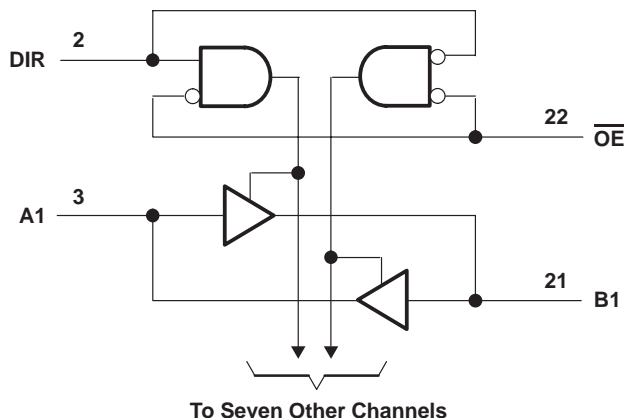

absolute maximum ratings over operating free-air temperature range (unless otherwise noted)†

Supply voltage range, V_{CCA} and V_{CCB}	-0.5 V to 6 V
Input voltage range, V_I : All A ports (see Note 1)	-0.5 V to $V_{CCA} + 0.5$ V
All B ports (see Note 2)	-0.5 V to $V_{CCB} + 0.5$ V
Except I/O ports (see Note 1)	-0.5 V to $V_{CCA} + 0.5$ V
Output voltage range, V_O (see Note 2): All A ports	-0.5 V to $V_{CCA} + 0.5$ V
All B ports	-0.5 V to $V_{CCB} + 0.5$ V
Input clamp current, I_{IK} ($V_I < 0$)	-50 mA
Output clamp current, I_{OK} ($V_O < 0$)	-50 mA
Continuous output current, I_O	± 50 mA
Continuous current through V_{CCA} , V_{CCB} , or GND	± 100 mA
Package thermal impedance, θ_{JA} (see Note 3): DB package	63°C/W
DW package	46°C/W
PW package	88°C/W
Storage temperature range, T_{stg}	-65°C to 150°C

† Stresses beyond those listed under “absolute maximum ratings” may cause permanent damage to the device. These are stress ratings only, and functional operation of the device at these or any other conditions beyond those indicated under “recommended operating conditions” is not implied. Exposure to absolute-maximum-rated conditions for extended periods may affect device reliability.

- NOTES: 1. This value is limited to 4.6 V maximum.
 2. This value is limited to 6 V maximum.
 3. The package thermal impedance is calculated in accordance with JESD 51-7.

SN74LVCC3245A-EP OCTAL BUS TRANSCEIVER WITH ADJUSTABLE OUTPUT VOLTAGE AND 3-STATE OUTPUTS

SCAS773A – JUNE 2004 – REVISED MARCH 2005

recommended operating conditions (see Note 4)

		V _{CCA}	V _{CCB}	MIN	NOM	MAX	UNIT
V _{CCA}	Supply voltage			2.3	3.3	3.6	V
V _{CCB}	Supply voltage			3	5	5.5	V
V _{IHA}	High-level input voltage	2.3 V	3 V	1.7			V
		2.7 V	3 V	2			
		3 V	3.6 V	2			
		3.6 V	5.5 V	2			
V _{IHB}	High-level input voltage	2.3 V	3 V	2			V
		2.7 V	3 V	2			
		3 V	3.6 V	2			
		3.6 V	5.5 V	3.85			
V _{ILA}	Low-level input voltage	2.3 V	3 V			0.7	V
		2.7 V	3 V			0.8	
		3 V	3.6 V			0.8	
		3.6 V	5.5 V			0.8	
V _{ILB}	Low-level input voltage	2.3 V	3 V			0.8	V
		2.7 V	3 V			0.8	
		3 V	3.6 V			0.8	
		3.6 V	5.5 V			1.65	
V _{IH}	High-level input voltage (control pins) (Referenced to V _{CCA})	2.3 V	3 V	1.7			V
		2.7 V	3 V	2			
		3 V	3.6 V	2			
		3.6 V	5.5 V	2			
V _{IL}	Low-level input voltage (control pins) (Referenced to V _{CCA})	2.3 V	3 V			0.7	V
		2.7 V	3 V			0.8	
		3 V	3.6 V			0.8	
		3.6 V	5.5 V			0.8	
V _{IA}	Input voltage			0		V _{CCA}	V
V _{IB}	Input voltage			0		V _{CCB}	V
V _{OA}	Output voltage			0		V _{CCA}	V
V _{OB}	Output voltage			0		V _{CCB}	V

NOTE 4: All unused inputs of the device must be held at the associated V_{CC} or GND to ensure proper device operation. Refer to the TI application report, *Implications of Slow or Floating CMOS Inputs*, literature number SCBA004.



SN74LVCC3245A-EP
OCTAL BUS TRANSCEIVER WITH ADJUSTABLE OUTPUT VOLTAGE
AND 3-STATE OUTPUTS

SCAS773A – JUNE 2004 – REVISED MARCH 2005

recommended operating conditions (see Note 4) (continued)

	V _{CCA}	V _{CCB}	MIN	NOM	MAX	UNIT
I _{OHA} High-level output current	2.3 V	3 V			-8	mA
	2.7 V	3 V			-12	
	3.3 V	3 V			-24	
I _{OHB} High-level output current	2.3 V	3.3 V			-12	mA
	2.7 V	3.3 V			-12	
	3.3 V	3 V			-24	
I _{OLA} Low-level output current	2.3 V	3 V			8	mA
	2.7 V	3 V			12	
	3.3 V	3 V			24	
I _{OLB} Low-level output current	2.3 V	3.3 V			12	mA
	2.7 V	3.3 V			12	
	3.3 V	3 V			24	
Δt/Δv Input transition rise or fall rate					10	ns/V
T _A Operating free-air temperature			-40		85	°C

NOTE 4: All unused inputs of the device must be held at the associated V_{CC} or GND to ensure proper device operation. Refer to the TI application report, *Implications of Slow or Floating CMOS Inputs*, literature number SCBA004.



SN74LVCC3245A-EP OCTAL BUS TRANSCEIVER WITH ADJUSTABLE OUTPUT VOLTAGE AND 3-STATE OUTPUTS

SCAS773A – JUNE 2004 – REVISED MARCH 2005

electrical characteristics over recommended operating free-air temperature range (unless otherwise noted)

PARAMETER		TEST CONDITIONS	V _{CCA}	V _{CCB}	MIN	TYP	MAX	UNIT
V _{OHA}		I _{OH} = -100 μA	3 V	3 V	2.9	3		V
		I _{OH} = -8 mA	2.3 V	3 V	2			
		I _{OH} = -12 mA	2.7 V	3 V	2.2	2.5		
			3 V	3 V	2.4	2.8		
		I _{OH} = -24 mA	3 V	3 V	2.2	2.6		
2.7 V	4.5 V		2	2.3				
V _{OHB}		I _{OH} = -100 μA	3 V	3 V	2.9	3		V
		I _{OH} = -12 mA	2.3 V	3 V	2.4			
			2.7 V	3 V	2.4	2.8		
		I _{OH} = -24 mA	3 V	3 V	2.2	2.6		
			2.7 V	4.5 V	3.2	4.2		
V _{OLA}		I _{OL} = 100 μA	3 V	3 V			0.1	V
		I _{OL} = 8 mA	2.3 V	3 V			0.6	
		I _{OL} = 12 mA	2.7 V	3 V		0.1	0.5	
			3 V	3 V		0.2	0.5	
		I _{OL} = 24 mA	2.7 V	4.5 V		0.2	0.5	
V _{OLB}		I _{OL} = 100 μA	3 V	3 V			0.1	V
		I _{OL} = 12 mA	2.3 V	3 V			0.4	
			3 V	3 V		0.2	0.5	
		I _{OL} = 24 mA		4.5 V		0.2	0.5	
I _I	Control inputs	V _I = V _{CCA} or GND	3.6 V	3.6 V 5.5 V		±0.1 ±0.1	±1 ±1	μA
I _{OZ} [†]	A or B ports	V _O = V _{CCA/B} or GND, V _I = V _{IL} or V _{IH}	3.6 V	3.6 V		±0.5	±5	μA
I _{CCA}	B to A	A port = V _{CCA} or GND, I _O = 0	3.6 V	Open		5	50	μA
		B port = V _{CCB} or GND, I _O = 0	3.6 V	3.6 V		5	50	
			5.5 V			5	50	
I _{CCB}	A to B	A port = V _{CCA} or GND, I _O = 0	3.6 V	3.6 V		5	50	μA
			5.5 V			8	80	
ΔI _{CCA} [‡]	A port	V _I = V _{CCA} - 0.6 V, Other inputs at V _{CCA} or GND, \overline{OE} at GND and DIR at V _{CCA}	3.6 V	3.6 V		0.35	0.5	mA
	\overline{OE}	V _I = V _{CCA} - 0.6 V, Other inputs at V _{CCA} or GND, DIR at V _{CCA}	3.6 V	3.6 V		0.35	0.5	
	DIR	V _I = V _{CCA} - 0.6 V, Other inputs at V _{CCA} or GND, \overline{OE} at GND	3.6 V	3.6 V		0.35	0.5	
ΔI _{CCB} [‡]	B port	V _I = V _{CCB} - 2.1 V, Other inputs at V _{CCB} or GND, \overline{OE} at GND and DIR at GND	3.6 V	5.5 V		1	1.5	mA
C _i	Control inputs	V _I = V _{CCA} or GND	Open	Open		4		pF
C _{io}	A or B ports	V _O = V _{CCA/B} or GND	3.3 V	5 V		18.5		pF

[†] For I/O ports, the parameter I_{OZ} includes the input leakage current.

[‡] This is the increase in supply current for each input that is at one of the specified voltage levels, rather than 0 V or the associated V_{CC}.



SN74LVCC3245A-EP

OCTAL BUS TRANSCEIVER WITH ADJUSTABLE OUTPUT VOLTAGE AND 3-STATE OUTPUTS

SCAS773A – JUNE 2004 – REVISED MARCH 2005

switching characteristics over recommended operating free-air temperature range (unless otherwise noted) (see Figures 1 through 4)

PARAMETER	FROM (INPUT)	TO (OUTPUT)	$V_{CCA} = 2.5\text{ V} \pm 0.2\text{ V}, V_{CCB} = 3.3\text{ V} \pm 0.3\text{ V}$		$V_{CCA} = 2.7\text{ V TO } 3.6\text{ V}, V_{CCB} = 5\text{ V} \pm 0.5\text{ V}$		$V_{CCA} = 2.7\text{ V TO } 3.6\text{ V}, V_{CCB} = 3.3\text{ V} \pm 0.3\text{ V}$		UNIT
			MIN	MAX	MIN	MAX	MIN	MAX	
t _{PHL}	A	B	1	9.4	1	6	1	7.1	ns
t _{PLH}			1	9.1	1	5.3	1	7.2	
t _{PHL}	B	A	1	11.2	1	5.8	1	6.4	ns
t _{PLH}			1	9.9	1	7	1	7.6	
t _{PZL}	$\overline{\text{OE}}$	A	1	14.5	1	9.2	1	9.7	ns
t _{PZH}			1	12.9	1	9.5	1	9.5	
t _{PZL}	$\overline{\text{OE}}$	B	1	13	1	8.1	1	9.2	ns
t _{PZH}			1	12.8	1	8.4	1	9.9	
t _{PLZ}	$\overline{\text{OE}}$	A	1	7.1	1	7	1	6.6	ns
t _{PHZ}			1	6.9	1	7.8	1	6.9	
t _{PLZ}	$\overline{\text{OE}}$	B	1	8.8	1	7.3	1	7.5	ns
t _{PHZ}			1	8.9	1	7	1	7.9	

operating characteristics, $V_{CCA} = 3.3\text{ V}, V_{CCB} = 5\text{ V}, T_A = 25^\circ\text{C}$

PARAMETER		TEST CONDITIONS	TYP	UNIT
C _{pd}	Power dissipation capacitance per transceiver	$C_L = 50, f = 10\text{ MHz}$	38	pF
			4.5	

power-up considerations†

TI level-translation devices offer an opportunity for successful mixed-voltage signal design. A proper power-up sequence always should be followed to avoid excessive supply current, bus contention, oscillations, or other anomalies caused by improperly biased device pins. To guard against such power-up problems, take these precautions:

1. Connect ground before any supply voltage is applied.
2. Power up the control side of the device (V_{CCA} for all four of these devices).
3. Tie $\overline{\text{OE}}$ to V_{CCA} with a pullup resistor so that it ramps with V_{CCA} .
4. Depending on the direction of the data path, DIR can be high or low. If DIR high is needed (A data to B bus), ramp it with V_{CCA} . Otherwise, keep DIR low.

† Refer to the TI application report, *Texas Instruments Voltage-Level-Translation Devices*, literature number SCEA021.



SN74LVCC3245A-EP OCTAL BUS TRANSCEIVER WITH ADJUSTABLE OUTPUT VOLTAGE AND 3-STATE OUTPUTS

SCAS773A – JUNE 2004 – REVISED MARCH 2005

PARAMETER MEASUREMENT INFORMATION FOR A PORT $V_{CCA} = 2.5\text{ V} \pm 0.2\text{ V}$ AND $V_{CCB} = 3.3\text{ V} \pm 0.3\text{ V}$

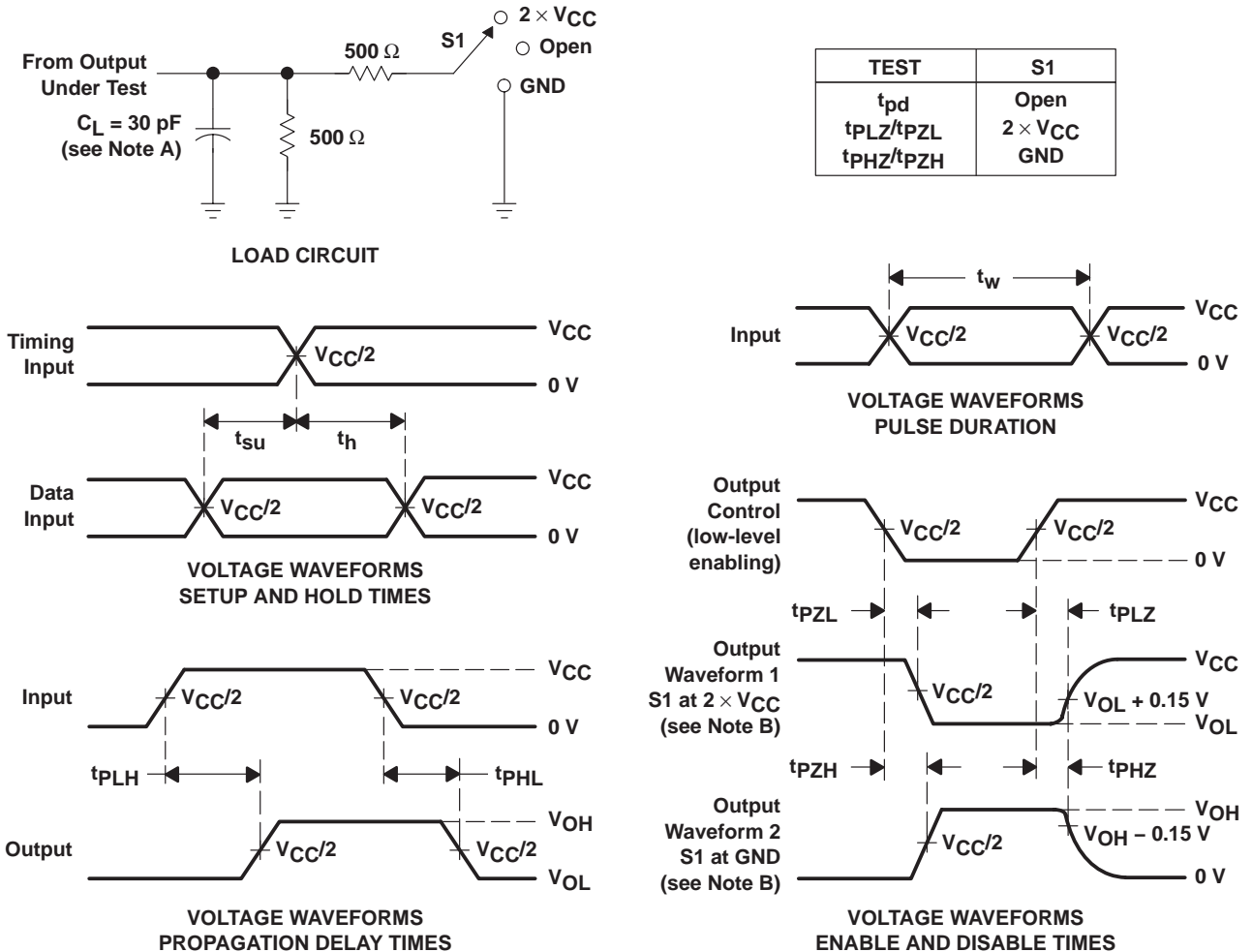

- NOTES:
- A. C_L includes probe and jig capacitance.
 - B. Waveform 1 is for an output with internal conditions such that the output is low, except when disabled by the output control. Waveform 2 is for an output with internal conditions such that the output is high, except when disabled by the output control.
 - C. All input pulses are supplied by generators having the following characteristics: $PRR \leq 10\text{ MHz}$, $Z_O = 50\ \Omega$, $t_r \leq 2\text{ ns}$, $t_f \leq 2\text{ ns}$.
 - D. The outputs are measured one at a time, with one transition per measurement.
 - E. t_{PLZ} and t_{PHZ} are the same as t_{dis} .
 - F. t_{PZL} and t_{PZH} are the same as t_{en} .
 - G. t_{PLH} and t_{PHL} are the same as t_{pd} .
 - H. All parameters and waveforms are not applicable to all devices.

Figure 1. Load Circuit and Voltage Waveforms

SN74LVCC3245A-EP OCTAL BUS TRANSCEIVER WITH ADJUSTABLE OUTPUT VOLTAGE AND 3-STATE OUTPUTS

SCAS773A – JUNE 2004 – REVISED MARCH 2005

PARAMETER MEASUREMENT INFORMATION FOR B PORT

$$V_{CCA} = 2.5 \text{ V} \pm 0.2 \text{ V AND } V_{CCB} = 3.3 \text{ V} \pm 0.3 \text{ V}$$

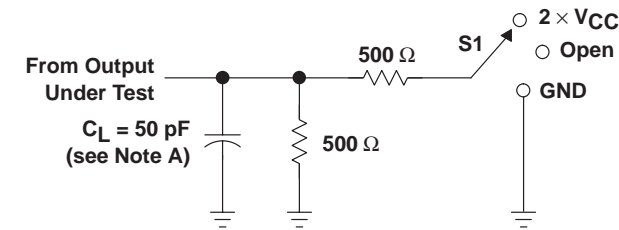

LOAD CIRCUIT

TEST	S1
t_{pd}	Open
t_{PLZ}/t_{PZL}	$2 \times V_{CC}$
t_{PHZ}/t_{PZH}	GND

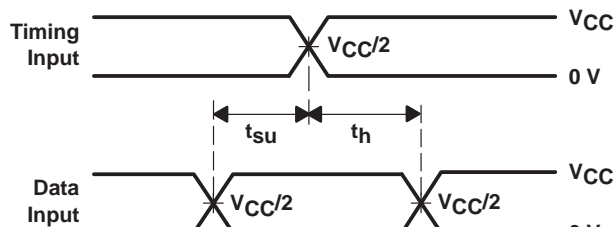

VOLTAGE WAVEFORMS
SETUP AND HOLD TIMES

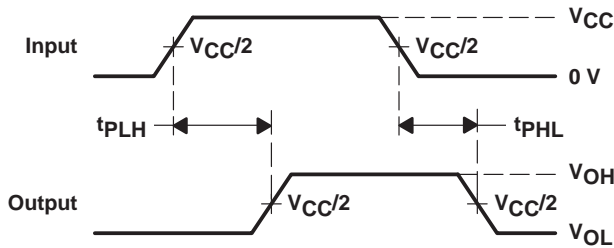

VOLTAGE WAVEFORMS
PROPAGATION DELAY TIMES

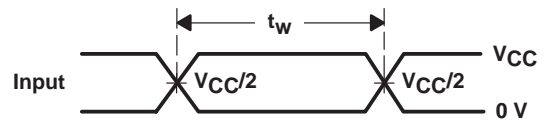

VOLTAGE WAVEFORMS
PULSE DURATION

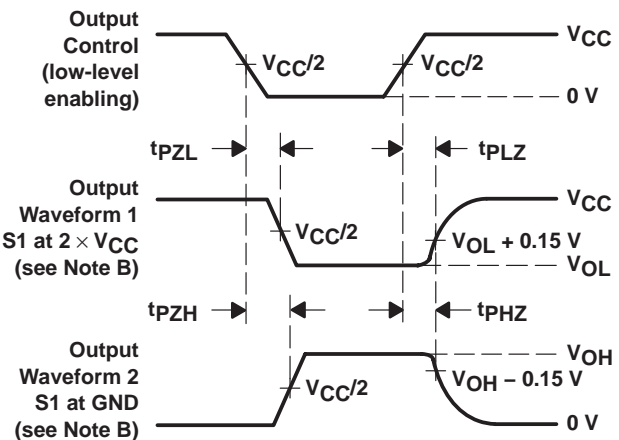

VOLTAGE WAVEFORMS
ENABLE AND DISABLE TIMES

- NOTES:
- C_L includes probe and jig capacitance.
 - Waveform 1 is for an output with internal conditions such that the output is low, except when disabled by the output control. Waveform 2 is for an output with internal conditions such that the output is high, except when disabled by the output control.
 - All input pulses are supplied by generators having the following characteristics: $PRR \leq 10 \text{ MHz}$, $Z_O = 50 \Omega$, $t_r \leq 2 \text{ ns}$, $t_f \leq 2 \text{ ns}$.
 - The outputs are measured one at a time, with one transition per measurement.
 - t_{PLZ} and t_{PHZ} are the same as t_{dis} .
 - t_{PZL} and t_{PZH} are the same as t_{en} .
 - t_{PLH} and t_{PHL} are the same as t_{pd} .
 - All parameters and waveforms are not applicable to all devices.

Figure 2. Load Circuit and Voltage Waveforms

SN74LVCC3245A-EP OCTAL BUS TRANSCEIVER WITH ADJUSTABLE OUTPUT VOLTAGE AND 3-STATE OUTPUTS

SCAS773A – JUNE 2004 – REVISED MARCH 2005

PARAMETER MEASUREMENT INFORMATION FOR B PORT $V_{CCA} = 3.6\text{ V}$ AND $V_{CCB} = 5.5\text{ V}$

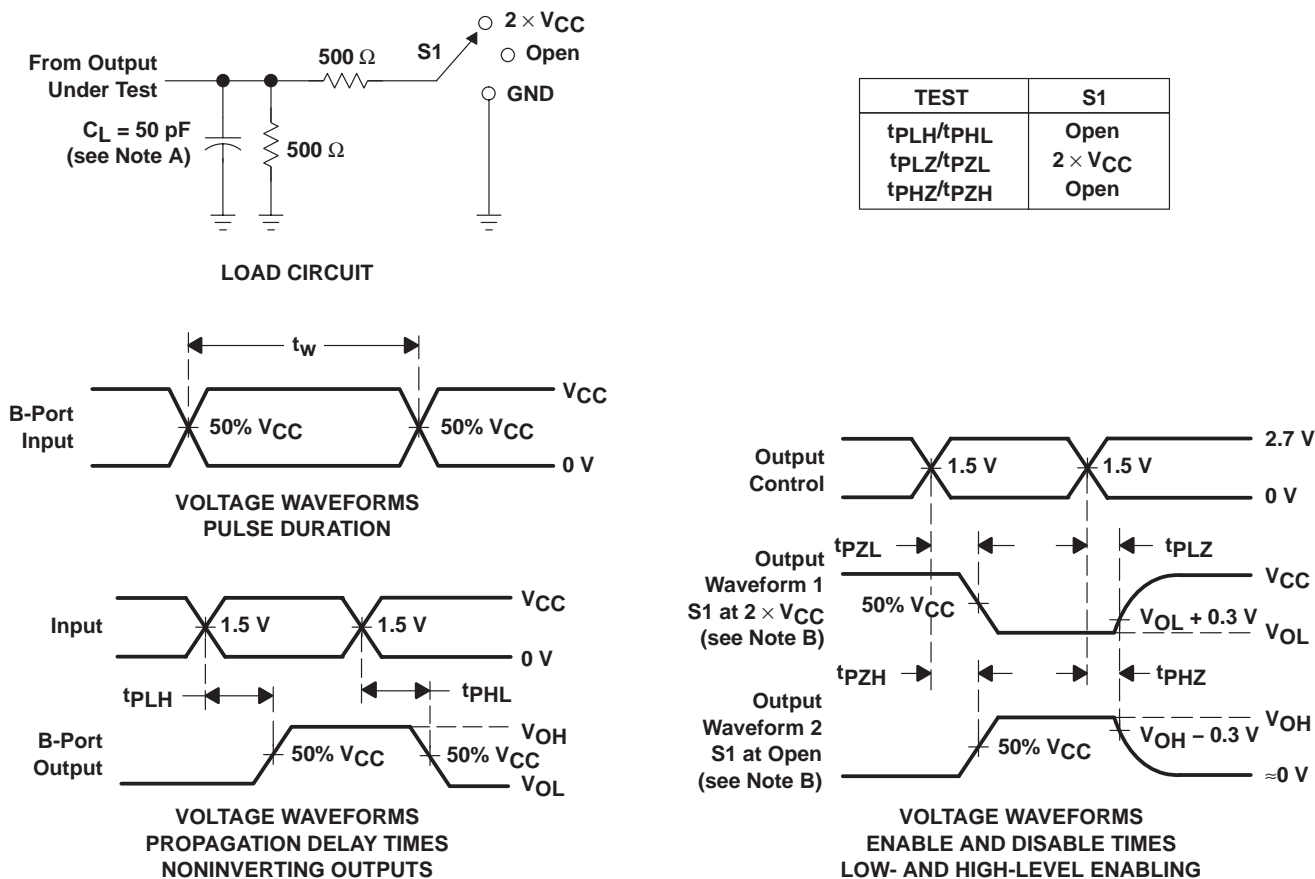

- NOTES:
- A. C_L includes probe and jig capacitance.
 - B. Waveform 1 is for an output with internal conditions such that the output is low, except when disabled by the output control. Waveform 2 is for an output with internal conditions such that the output is high, except when disabled by the output control.
 - C. All input pulses are supplied by generators having the following characteristics: $PRR \leq 10\text{ MHz}$, $Z_O = 50\ \Omega$, $t_r \leq 2.5\text{ ns}$, $t_f \leq 2.5\text{ ns}$.
 - D. The outputs are measured one at a time, with one transition per measurement.
 - E. All parameters and waveforms are not applicable to all devices.

Figure 3. Load Circuit and Voltage Waveforms

SN74LVCC3245A-EP OCTAL BUS TRANSCEIVER WITH ADJUSTABLE OUTPUT VOLTAGE AND 3-STATE OUTPUTS

SCAS773A – JUNE 2004 – REVISED MARCH 2005

PARAMETER MEASUREMENT INFORMATION FOR A AND B PORT V_{CCA} AND $V_{CCB} = 3.6\text{ V}$

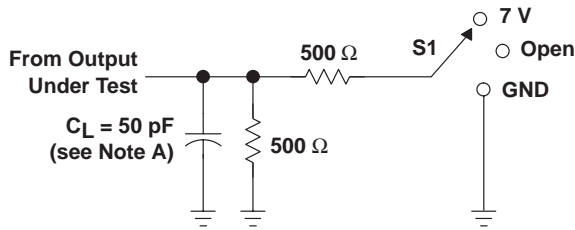

LOAD CIRCUIT

TEST	S1
t_{PLH}/t_{PHL}	Open
t_{PLZ}/t_{PZL}	7 V
t_{PHZ}/t_{PZH}	Open

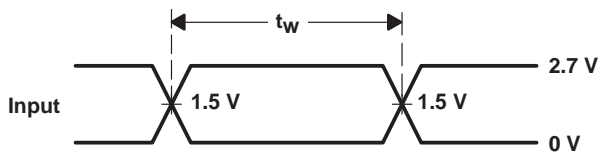

VOLTAGE WAVEFORMS
PULSE DURATION

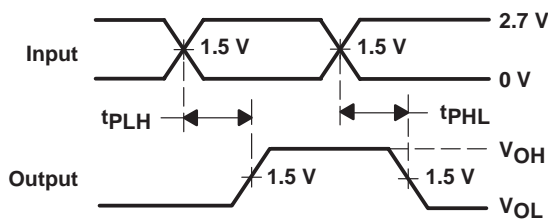

VOLTAGE WAVEFORMS
PROPAGATION DELAY TIMES
NONINVERTING OUTPUTS

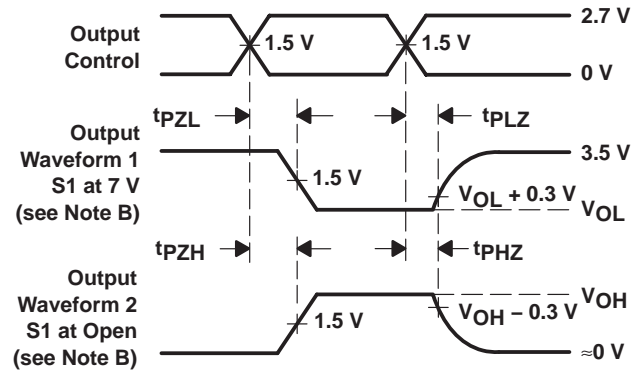

VOLTAGE WAVEFORMS
ENABLE AND DISABLE TIMES
LOW- AND HIGH-LEVEL ENABLING

- NOTES: A. C_L includes probe and jig capacitance.
 B. Waveform 1 is for an output with internal conditions such that the output is low, except when disabled by the output control. Waveform 2 is for an output with internal conditions such that the output is high, except when disabled by the output control.
 C. All input pulses are supplied by generators having the following characteristics: $PRR \leq 10\text{ MHz}$, $Z_O = 50\ \Omega$, $t_r \leq 2.5\text{ ns}$, $t_f \leq 2.5\text{ ns}$.
 D. The outputs are measured one at a time, with one transition per measurement.
 E. All parameters and waveforms are not applicable to all devices.

Figure 4. Load Circuit and Voltage Waveforms

PACKAGING INFORMATION

Orderable part number	Status (1)	Material type (2)	Package Pins	Package qty Carrier	RoHS (3)	Lead finish/ Ball material (4)	MSL rating/ Peak reflow (5)	Op temp (°C)	Part marking (6)
CLVCC3245AIDBREP	Active	Production	SSOP (DB) 24	2000 LARGE T&R	Yes	NIPDAU	Level-1-260C-UNLIM	-40 to 85	LH245AEP
CLVCC3245AIDWREP	Active	Production	SOIC (DW) 24	2000 LARGE T&R	Yes	NIPDAU	Level-1-260C-UNLIM	-40 to 85	LVCC3245A
CLVCC3245AIPWREP	Active	Production	TSSOP (PW) 24	2000 LARGE T&R	Yes	NIPDAU	Level-1-260C-UNLIM	-40 to 85	LH245AEP
V62/05602-01XE	Active	Production	TSSOP (PW) 24	2000 LARGE T&R	Yes	NIPDAU	Level-1-260C-UNLIM	-40 to 85	LH245AEP
V62/05602-01YE	Active	Production	SSOP (DB) 24	2000 LARGE T&R	Yes	NIPDAU	Level-1-260C-UNLIM	-40 to 85	LH245AEP
V62/05602-01ZE	Active	Production	SOIC (DW) 24	2000 LARGE T&R	Yes	NIPDAU	Level-1-260C-UNLIM	-40 to 85	LVCC3245A

(1) **Status:** For more details on status, see our [product life cycle](#).

(2) **Material type:** When designated, preproduction parts are prototypes/experimental devices, and are not yet approved or released for full production. Testing and final process, including without limitation quality assurance, reliability performance testing, and/or process qualification, may not yet be complete, and this item is subject to further changes or possible discontinuation. If available for ordering, purchases will be subject to an additional waiver at checkout, and are intended for early internal evaluation purposes only. These items are sold without warranties of any kind.

(3) **RoHS values:** Yes, No, RoHS Exempt. See the [TI RoHS Statement](#) for additional information and value definition.

(4) **Lead finish/Ball material:** Parts may have multiple material finish options. Finish options are separated by a vertical ruled line. Lead finish/Ball material values may wrap to two lines if the finish value exceeds the maximum column width.

(5) **MSL rating/Peak reflow:** The moisture sensitivity level ratings and peak solder (reflow) temperatures. In the event that a part has multiple moisture sensitivity ratings, only the lowest level per JEDEC standards is shown. Refer to the shipping label for the actual reflow temperature that will be used to mount the part to the printed circuit board.

(6) **Part marking:** There may be an additional marking, which relates to the logo, the lot trace code information, or the environmental category of the part.

Multiple part markings will be inside parentheses. Only one part marking contained in parentheses and separated by a "~" will appear on a part. If a line is indented then it is a continuation of the previous line and the two combined represent the entire part marking for that device.

Important Information and Disclaimer:The information provided on this page represents TI's knowledge and belief as of the date that it is provided. TI bases its knowledge and belief on information provided by third parties, and makes no representation or warranty as to the accuracy of such information. Efforts are underway to better integrate information from third parties. TI has taken and continues to take reasonable steps to provide representative and accurate information but may not have conducted destructive testing or chemical analysis on incoming materials and chemicals. TI and TI suppliers consider certain information to be proprietary, and thus CAS numbers and other limited information may not be available for release.

In no event shall TI's liability arising out of such information exceed the total purchase price of the TI part(s) at issue in this document sold by TI to Customer on an annual basis.

OTHER QUALIFIED VERSIONS OF SN74LVCC3245A-EP :

- Catalog : [SN74LVCC3245A](#)

NOTE: Qualified Version Definitions:

- Catalog - TI's standard catalog product

TAPE AND REEL INFORMATION

QUADRANT ASSIGNMENTS FOR PIN 1 ORIENTATION IN TAPE



*All dimensions are nominal

Device	Package Type	Package Drawing	Pins	SPQ	Reel Diameter (mm)	Reel Width W1 (mm)	A0 (mm)	B0 (mm)	K0 (mm)	P1 (mm)	W (mm)	Pin1 Quadrant
CLVCC3245AIDBREP	SSOP	DB	24	2000	330.0	16.4	8.2	8.8	2.5	12.0	16.0	Q1
CLVCC3245AIDWREP	SOIC	DW	24	2000	330.0	24.4	10.75	15.7	2.7	12.0	24.0	Q1
CLVCC3245AIPWREP	TSSOP	PW	24	2000	330.0	16.4	6.95	8.3	1.6	8.0	16.0	Q1

TAPE AND REEL BOX DIMENSIONS

*All dimensions are nominal

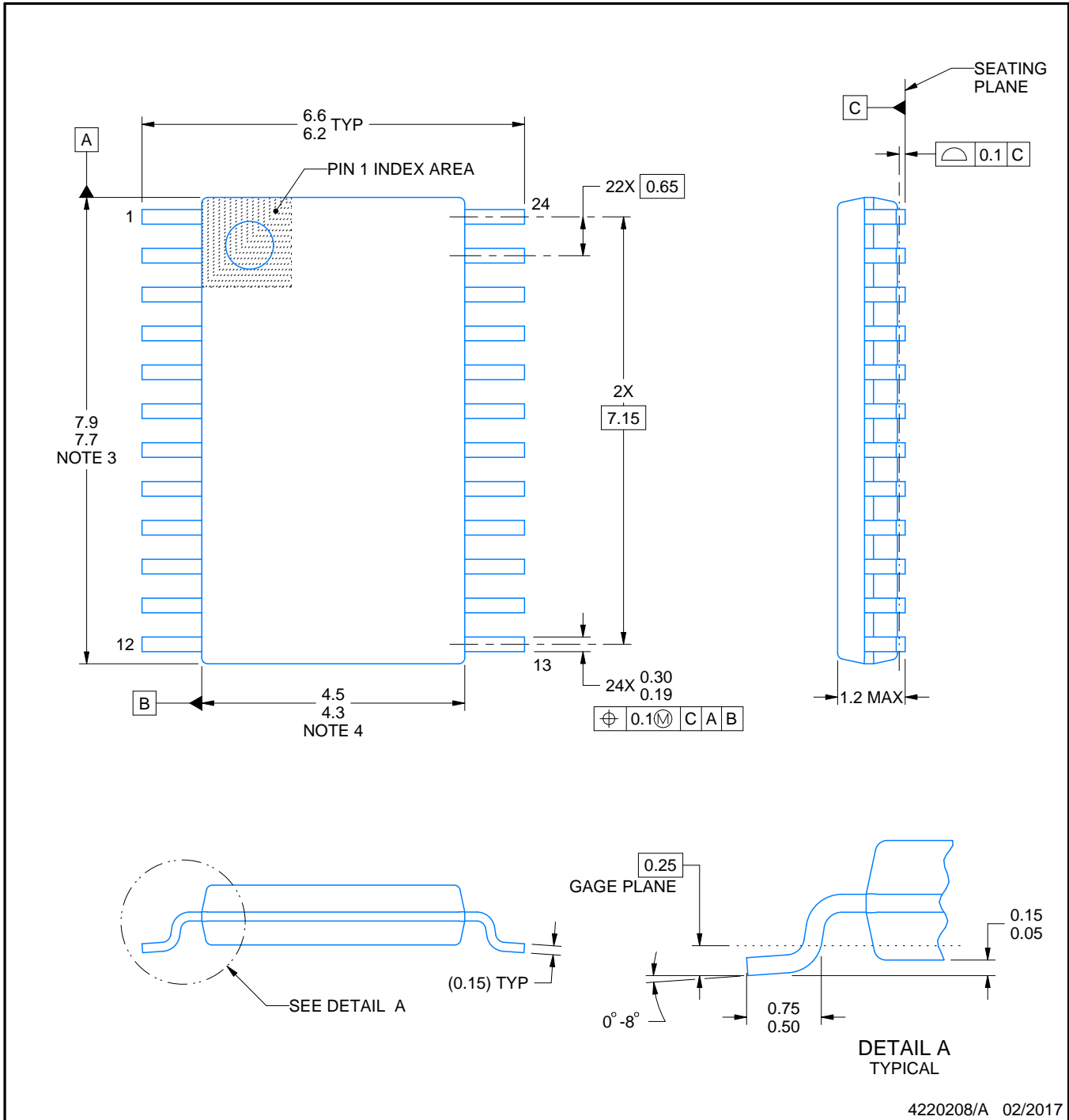
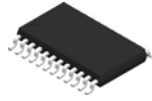
Device	Package Type	Package Drawing	Pins	SPQ	Length (mm)	Width (mm)	Height (mm)
CLVCC3245AIDBREP	SSOP	DB	24	2000	353.0	353.0	32.0
CLVCC3245AIDWREP	SOIC	DW	24	2000	350.0	350.0	43.0
CLVCC3245AIPWREP	TSSOP	PW	24	2000	353.0	353.0	32.0



4220208/A 02/2017

NOTES:

1. All linear dimensions are in millimeters. Any dimensions in parenthesis are for reference only. Dimensioning and tolerancing per ASME Y14.5M.
2. This drawing is subject to change without notice.
3. This dimension does not include mold flash, protrusions, or gate burrs. Mold flash, protrusions, or gate burrs shall not exceed 0.15 mm per side.
4. This dimension does not include interlead flash. Interlead flash shall not exceed 0.25 mm per side.
5. Reference JEDEC registration MO-153.

EXAMPLE BOARD LAYOUT

PW0024A

TSSOP - 1.2 mm max height

SMALL OUTLINE PACKAGE



LAND PATTERN EXAMPLE
EXPOSED METAL SHOWN
SCALE: 10X

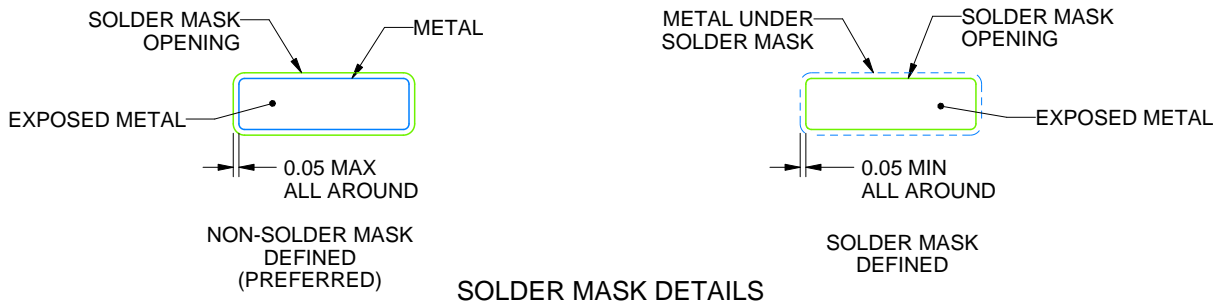

SOLDER MASK DETAILS

4220208/A 02/2017

NOTES: (continued)

- 6. Publication IPC-7351 may have alternate designs.
- 7. Solder mask tolerances between and around signal pads can vary based on board fabrication site.

EXAMPLE STENCIL DESIGN

PW0024A

TSSOP - 1.2 mm max height

SMALL OUTLINE PACKAGE



NOTES: (continued)

8. Laser cutting apertures with trapezoidal walls and rounded corners may offer better paste release. IPC-7525 may have alternate design recommendations.
9. Board assembly site may have different recommendations for stencil design.

DW (R-PDSO-G24)

PLASTIC SMALL OUTLINE



- NOTES:
- All linear dimensions are in inches (millimeters). Dimensioning and tolerancing per ASME Y14.5M-1994.
 - This drawing is subject to change without notice.
 - Body dimensions do not include mold flash or protrusion not to exceed 0.006 (0,15).
 - Falls within JEDEC MS-013 variation AD.

DB (R-PDSO-G**)

PLASTIC SMALL-OUTLINE

28 PINS SHOWN



- NOTES: A. All linear dimensions are in millimeters.
 B. This drawing is subject to change without notice.
 C. Body dimensions do not include mold flash or protrusion not to exceed 0,15.
 D. Falls within JEDEC MO-150

IMPORTANT NOTICE AND DISCLAIMER

TI PROVIDES TECHNICAL AND RELIABILITY DATA (INCLUDING DATA SHEETS), DESIGN RESOURCES (INCLUDING REFERENCE DESIGNS), APPLICATION OR OTHER DESIGN ADVICE, WEB TOOLS, SAFETY INFORMATION, AND OTHER RESOURCES "AS IS" AND WITH ALL FAULTS, AND DISCLAIMS ALL WARRANTIES, EXPRESS AND IMPLIED, INCLUDING WITHOUT LIMITATION ANY IMPLIED WARRANTIES OF MERCHANTABILITY, FITNESS FOR A PARTICULAR PURPOSE OR NON-INFRINGEMENT OF THIRD PARTY INTELLECTUAL PROPERTY RIGHTS.

These resources are intended for skilled developers designing with TI products. You are solely responsible for (1) selecting the appropriate TI products for your application, (2) designing, validating and testing your application, and (3) ensuring your application meets applicable standards, and any other safety, security, regulatory or other requirements.

These resources are subject to change without notice. TI grants you permission to use these resources only for development of an application that uses the TI products described in the resource. Other reproduction and display of these resources is prohibited. No license is granted to any other TI intellectual property right or to any third party intellectual property right. TI disclaims responsibility for, and you will fully indemnify TI and its representatives against, any claims, damages, costs, losses, and liabilities arising out of your use of these resources.

TI's products are provided subject to [TI's Terms of Sale](#) or other applicable terms available either on [ti.com](https://www.ti.com) or provided in conjunction with such TI products. TI's provision of these resources does not expand or otherwise alter TI's applicable warranties or warranty disclaimers for TI products.

TI objects to and rejects any additional or different terms you may have proposed.

Mailing Address: Texas Instruments, Post Office Box 655303, Dallas, Texas 75265
Copyright © 2025, Texas Instruments Incorporated