

SN65HVD23x-Q1 3.3-V Automotive CAN Bus Transceivers

1 Features

- Compatible With ISO 11898-2
- Qualified for Automotive Applications
- AEC-Q100 Qualified With the Following Results:
 - Device Temperature Grade 1: -40°C to 125°C Ambient Operating Temperature Range
 - Device HBM ESD Classification Levels
 - Bus Pins: $\pm 12\,000\text{ V}$
 - Other Pins: $\pm 3\,000\text{ V}$
 - Device CDM ESD Classification Level $\pm 1\,000\text{ V}$
- Single 3.3-V Supply Voltage
- Bit Rates up to 1 Mbps
- Bus Pins Fault Protection up to $\pm 36\text{ V}$
- -7-V to 12-V Common-Mode Range
- High Input Impedance Allows for 120 Nodes
- LVTTTL I/Os are 5-V Tolerant
- GIFT/ICT Compliant
- Adjustable Driver Slew Rates for Improved Emissions Performance
- Unpowered Node Does Not Disturb the Bus
- Low-Current Standby Mode, $200\text{-}\mu\text{A}$ (Typical)
- Average Power Dissipation: 36.4 mW
- SN65HVD233-Q1: Loopback Mode
- SN65HVD234-Q1: Ultralow-Current Sleep Mode
 - 50-nA Typical Current Consumption
- SN65HVD235-Q1: Autobaud Loopback Mode
- Thermal Shutdown Protection
- Power Up and Down With Glitch-Free Bus Inputs and Outputs
 - High Input Impedance With Low V_{CC}
 - Monotonic Output During Power Cycling

2 Applications

- In-Vehicle Networking
- Advanced Driver-Assistance Systems (ADAS)
- Body Electronics and Lighting
- Infotainment and Cluster
- Hybrid, Electric, and Powertrain Systems
- Applications in Accordance With CAN Bus Standards Such as NMEA 2000 and SAE J1939

3 Description

The SN65HVD233-Q1, SN65HVD234-Q1, and SN65HVD235-Q1 devices are fault-protected 3.3-V CAN transceivers that are qualified for use in automotive applications. These transceivers work from a 3.3-V supply and are ideal for systems that also leverage a 3.3-V microcontroller, thereby reducing the need for additional components or a separate supply to power the controller and the CAN transceiver. The SN65HVD23x-Q1 transceivers are compatible with the ISO 11898-2 standard and thus are interoperable in mixed networks that employ 5-V CAN and/or 3.3-V CAN transceivers.

Designed for operation in especially harsh environments, the devices feature crosswire protection, overvoltage protection on the CANH and CANL pins up to $\pm 36\text{ V}$, loss-of-ground protection, overtemperature (thermal shutdown) protection, and common-mode transient protection of $\pm 100\text{ V}$. These devices operate over a wide -7-V to 12-V common-mode range. These transceivers are the interface between the host CAN controller on the microprocessor and the differential CAN bus used in transportation and automotive applications.

Device Information⁽¹⁾

PART NUMBER	PACKAGE	BODY SIZE (NOM)
SN65HVD233-Q1	SOIC (8)	4.90 mm x 3.91 mm
SN65HVD234-Q1		
SN65HVD235-Q1		

(1) For all available packages, see the orderable addendum at the end of the data sheet.

Block Diagram

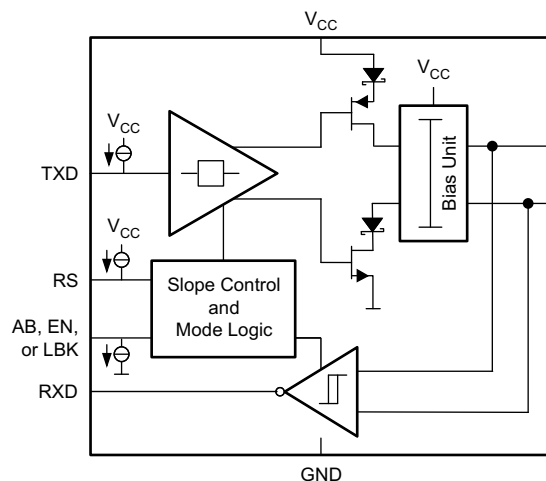

Table of Contents

1 Features	1	10.1 Overview	18
2 Applications	1	10.2 Functional Block Diagrams	18
3 Description	1	10.3 Feature Description	18
4 Revision History	2	10.4 Device Functional Modes	20
5 Description (continued)	3	11 Application and Implementation	22
6 Device Comparison Table	3	11.1 Application Information	22
7 Pin Configuration and Functions	4	11.2 Typical Application	23
8 Specifications	5	11.3 System Example	25
8.1 Absolute Maximum Ratings	5	12 Power Supply Recommendations	26
8.2 ESD Ratings	5	13 Layout	26
8.3 Recommended Operating Conditions	5	13.1 Layout Guidelines	26
8.4 Thermal Information	6	13.2 Layout Example	27
8.5 Electrical Characteristics: Driver	6	14 Device and Documentation Support	28
8.6 Electrical Characteristics: Receiver	7	14.1 Related Links	28
8.7 Switching Characteristics: Driver	7	14.2 Receiving Notification of Documentation Updates	28
8.8 Switching Characteristics: Receiver	8	14.3 Community Resources	28
8.9 Switching Characteristics: Device	8	14.4 Trademarks	28
8.10 Typical Characteristics	9	14.5 Electrostatic Discharge Caution	28
9 Parameter Measurement Information	11	14.6 Glossary	28
10 Detailed Description	18	15 Mechanical, Packaging, and Orderable Information	28

4 Revision History

NOTE: Page numbers for previous revisions may differ from page numbers in the current version.

Changes from Original (September 2016) to Revision A

Page

• Deleted extra words "all pins except" in the test condition for CANH, CANL pins to GND	5
• Added ESD performance information between CANH and CANL pins	5

5 Description (continued)

Modes: The RS pin (pin 8) of the SN65HVD233-Q1, SN65HVD234-Q1, and SN65HVD235-Q1 devices provides three modes of operation: high-speed, slope control, and low-power standby mode. The high-speed mode of operation is selected by connecting pin 8 directly to ground, allowing the driver output transistors to switch on and off as fast as possible with no limitation on the rise and fall slope. The rise and fall slope can be adjusted by connecting a resistor between the RS pin and ground. The slope is proportional to the output current of the pin. With a resistor value of 10 k Ω the device driver has a slew rate of approximately 15 V/ μ s, and with a value of 100 k Ω the device has a slew rate of approximately 2 V/ μ s. For more information about slope control, see [Feature Description](#).

The SN65HVD233-Q1, SN65HVD234-Q1, and SN65HVD235-Q1 devices enter a low-current standby (listen-only) mode during which the driver is switched off and the receiver remains active if a high logic level is applied to the RS pin. If the local protocol controller must transmit a message to the bus, it must return also the device to either high-speed mode or slope-control mode via the RS pin.

Loopback (SN65HVD233-Q1): A logic high on the loopback (LBK) pin (pin 5) of the SN65HVD233-Q1 device places the bus output and bus input in a high-impedance state. Internally, the TXD-to-RS path of the device remains active and available for driver-to-receiver loopback that can be used for self-diagnostic node functions without disturbing the bus. For more information on the loopback mode, see [Feature Description](#).

Ultralow-Current Sleep (SN65HVD234-Q1): The SN65HVD234-Q1 device enters an ultralow-current sleep mode in which both the driver and receiver circuits are deactivated if a low logic level is applied to EN pin (pin 5). The device remains in this sleep mode until the circuit is reactivated by applying a high logic level to pin 5.

Autobaud Loopback (SN65HVD235-Q1): The AB pin (pin 5) of the SN65HVD235-Q1 device implements a bus listen-only loopback feature which allows the local node controller to synchronize its baud rate with that of the CAN bus. In autobaud mode, the bus output of the driver is placed in a high-impedance state while the bus input of the receiver remains active. There is an internal TXD pin to RS pin loopback to assist the controller in baud rate detection, or the autobaud function. For more information on the autobaud mode, see [Feature Description](#).

6 Device Comparison Table

PART NUMBER ⁽¹⁾	LOW-POWER MODE	SLOPE CONTROL	DIAGNOSTIC LOOPBACK	AUTOBAUD LOOPBACK
SN65HVD233-Q1	200- μ A standby mode	Adjustable	Yes	No
SN65HVD234-Q1	200- μ A standby mode or 50-nA sleep mode	Adjustable	No	No
SN65HVD235-Q1	200- μ A standby mode	Adjustable	No	Yes

(1) For the most-current package and ordering information, see the orderable addendum at the end of the data sheet, or see the TI Web site at www.ti.com.

7 Pin Configuration and Functions

**D Package
8-Pin SOIC
SN65HVD233-Q1 Top View**

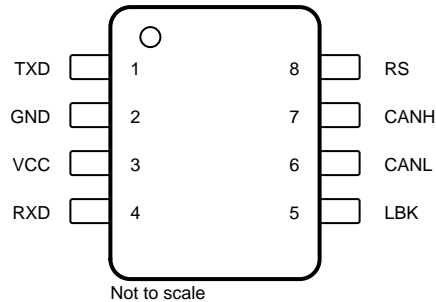

**D Package
8-Pin SOIC
SN65HVD234-Q1 Top View**

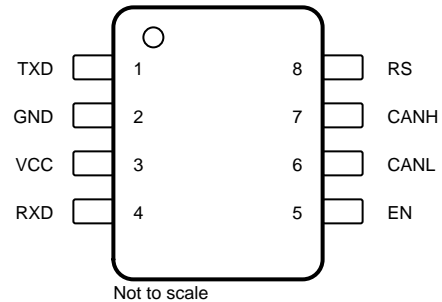

**D Package
8-Pin SOIC
SN65HVD235-Q1 Top View**

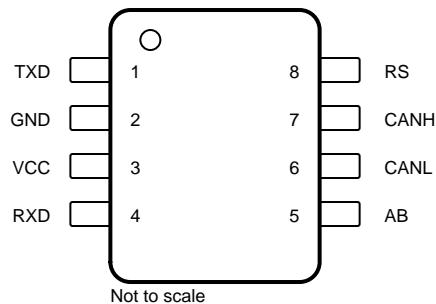

Pin Functions

NAME	PIN NO.			I/O	DESCRIPTION
	'233-Q1	'234-Q1	'235-Q1		
AB	—	—	5	I	SN65HVD235-Q1 device: Autobaud loopback mode-input pin (AB). Can be tied to ground if not used. Can also be left open if unused because the internal pulldown biases this toward ground.
CANH	7	7	7	I/O	High-level CAN bus line
CANL	6	6	6	I/O	Low-level CAN bus line
EN	—	5	—	I	SN65HVD234-Q1 device: Enable input pin. Logic high for enabling a normal mode (high-speed or slope-control mode). Logic low for sleep mode. (EN)
GND	2	2	2	—	Ground connection
LBK	5	—	—	I	SN65HVD233-Q1 device: Loopback-mode input pin (LBK). Can be tied to ground if not used. Can also be left open if unused because the internal pulldown biases this toward ground.
RS	8	8	8	I	Mode-select pin: strong pulldown to GND = high-speed mode, strong pullup to V_{CC} = low-power mode, 10-k Ω to 100-k Ω pulldown to GND = slope-control mode
RXD	4	4	4	O	CAN receive data output (LOW for dominant and HIGH for recessive bus states)
TXD	1	1	1	I	CAN transmit data input (LOW for dominant and HIGH for recessive bus states)
V_{CC}	3	3	3	I	Transceiver 3.3-V supply voltage

8 Specifications

8.1 Absolute Maximum Ratings

over operating ambient temperature range unless otherwise noted⁽¹⁾⁽²⁾

		MIN	MAX	UNIT	
V _{CC}	Supply voltage	-0.3	7	V	
	Voltage at any bus terminal (CANH or CANL)		-36	36	V
	Voltage input, transient pulse, CANH and CANL, through 100 Ω (see Figure 18)		-100	100	V
V _I	Input voltage, (AB, EN, LBK, RS, TXD)	-0.5	7	V	
V _O	Output voltage (RXD)	-0.5	7	V	
I _O	Receiver output current	-10	10	mA	
T _J	Operating junction temperature	-40	150	°C	
T _{stg}	Storage temperature		125	°C	

- (1) Stresses beyond those listed under *Absolute Maximum Ratings* may cause permanent damage to the device. These are stress ratings only, and functional operation of the device at these or any other conditions beyond those indicated under *Recommended Operating Conditions* is not implied. Exposure to absolute-maximum-rated conditions for extended periods may affect device reliability.
- (2) All voltage values, except differential I/O bus voltages, are with respect to the network ground pin.

8.2 ESD Ratings

			VALUE	UNIT	
V _(ESD)	Electrostatic discharge	Human-body model (HBM), per AEC Q100-002 ⁽¹⁾	CANH, CANL to GND	±12 000	V
			Between CANH and CANL	±16 000	
			All pins	±3 000	
		Charged-device model (CDM), per AEC Q100-011	±1 000		

- (1) AEC Q100-002 indicates that HBM stressing shall be in accordance with the ANSI/ESDA/JEDEC JS-001 specification.

8.3 Recommended Operating Conditions

			MIN	MAX	UNIT
V _{CC}	Supply voltage		3	3.6	V
	Voltage at any bus terminal (separately or common mode)		-7	12	V
V _{IH}	High-level input voltage	EN, AB, LBK, TXD	2	5.5	V
V _{IL}	Low-level input voltage	EN, AB, LBK, TXD	0	0.8	V
V _{ID}	Differential input voltage between CANH and CANL		-6	6	V
	Resistance from RS to ground		0	100	kΩ
V _{I(RS)}	Input voltage at RS for standby		0.75 V _{CC}	5.5	V
I _{OH}	High-level output current	Driver	-50		mA
		Receiver	-10		
I _{OL}	Low-level output current	Driver		50	mA
		Receiver		10	
T _A	Operating ambient temperature ⁽¹⁾		-40	125	°C

- (1) Maximum ambient temperature operation is allowed as long as the device maximum junction temperature is not exceeded.

8.4 Thermal Information

THERMAL METRIC ⁽¹⁾		SN65HVD23x-Q1	
		D (SOIC)	
		8 PINS	
Symbol	Description	Value	Unit
$R_{\theta JA}$	Junction-to-ambient thermal resistance	102.8	°C/W
$R_{\theta JC(top)}$	Junction-to-case (top) thermal resistance	45.1	°C/W
$R_{\theta JB}$	Junction-to-board thermal resistance	43.8	°C/W
ψ_{JT}	Junction-to-top characterization parameter	7.3	°C/W
ψ_{JB}	Junction-to-board characterization parameter	43.2	°C/W

(1) For more information about traditional and new thermal metrics, see the *Semiconductor and IC Package Thermal Metrics* application report, [SPRA953](#).

8.5 Electrical Characteristics: Driver

over operating ambient temperature range (unless otherwise noted)

PARAMETER			TEST CONDITIONS	MIN	TYP ⁽¹⁾	MAX	UNIT
$V_{O(D)}$	Bus output voltage (dominant)	CANH	TXD at 0 V, RS at 0 V, see Figure 12 and Figure 13	2.45		V_{CC}	V
		CANL		0.5	1.25		
V_O	Bus output voltage (recessive)	CANH	TXD at 3 V, RS at 0 V, see Figure 12 and Figure 13	2.3			V
		CANL		2.3			
$V_{OD(D)}$	Differential output voltage (dominant)		TXD at 0 V, RS at 0 V, see Figure 12 and Figure 13	1.5	2	3	V
				TXD at 0 V, RS at 0 V, see Figure 13 and Figure 14	1.2	2	
V_{OD}	Differential output voltage (recessive)		TXD at 3 V, RS at 0 V, see Figure 12 and Figure 13		-120		12
				TXD at 3 V, RS at 0 V, no load	-0.5		0.05
$V_{OC(pp)}$	Peak-to-peak common-mode output voltage	See Figure 21			1		V
I_{IH}	High-level input current	AB, EN, LBK, TXD	TXD = 2 V or EN = 2 V or LBK = 2 V or AB = 2 V	-30		30	μA
I_{IL}	Low-level input current	AB, EN, LBK, TXD	TXD = 0.8 V or EN = 0.8 V or LBK = 0.8 V or AB = 0.8 V	-30		30	μA
I_{OS}	Short-circuit output current		$V_{CANH} = -7$ V, CANL open, see Figure 26	-250			mA
			$V_{CANH} = 12$ V, CANL open, see Figure 26			1	
			$V_{CANL} = -7$ V, CANH open, see Figure 26	-1			
			$V_{CANL} = 12$ V, CANH open, see Figure 26			250	
C_O	Output capacitance		See C_I , Input capacitance in Electrical Characteristics: Receiver				
$I_{IRs(s)}$	RS input current for standby		RS at 0.75 V_{CC}	-10			μA
I_{CC}	Supply current	Sleep	EN at 0 V, TXD at V_{CC} , RS at 0 V or V_{CC}		0.05	2	μA
		Standby	RS at V_{CC} , TXD at V_{CC} , AB at 0 V, LBK at 0 V, EN at V_{CC}		200	600	
		Dominant	TXD at 0 V, no load, AB at 0 V, LBK at 0 V, RS at 0 V, EN at V_{CC}			6	mA
		Recessive	TXD at V_{CC} , no load, AB at 0 V, LBK at 0 V, RS at 0 V, EN at V_{CC}			6	
$P_{(AVG)}$	Average power dissipation		$R_L = 60$ Ω, R_S at 0 V, input to D a 1-MHz 50% duty cycle square wave V_{CC} at 3.3 V, $T_A = 25$ °C		36.4		mW

(1) All typical values are at 25°C and with a 3.3-V supply.

8.6 Electrical Characteristics: Receiver

over operating ambient temperature range (unless otherwise noted)

PARAMETER		TEST CONDITIONS	MIN	TYP ⁽¹⁾	MAX	UNIT	
V _{IT+}	Positive-going input threshold voltage	AB at 0 V, LBK at 0 V, EN at V _{CC} , see Table 1		750	900	mV	
V _{IT-}	Negative-going input threshold voltage		500	650		mV	
V _{hys}	Hysteresis voltage (V _{IT+} – V _{IT-})			100		mV	
V _{OH}	High-level output voltage	I _O = –4 mA, See Figure 17		0.8 × V _{CC}		V	
V _{OL}	Low-level output voltage	I _O = 4 mA, See Figure 17			0.4	V	
I _I	Bus input current	CANH or CANL at 12 V		150	500	μA	
		CANH or CANL at 12 V, V _{CC} at 0 V		200	600		
		CANH or CANL at –7 V	Other bus pin at 0 V, TXD at 3 V, AB at 0 V, LBK at 0 V, RS at 0 V, EN at V _{CC}	–610	–150		
		CANH or CANL at –7 V, V _{CC} at 0 V		–450	–130		
C _I	Input capacitance (CANH or CANL)	Pin-to-ground, V _I = 0.4 sin(4E6πt) + 0.5 V, TXD at 3 V, AB at 0 V, LBK at 0 V, EN at V _{CC}		40		pF	
C _{ID}	Differential input capacitance	Pin-to-pin, V _I = 0.4 sin(4E6πt) + 0.5 V, TXD at 3 V, AB at 0 V, LBK at 0 V, EN at V _{CC}		20		pF	
R _{ID}	Differential input resistance		40		100	kΩ	
R _{IN}	Input resistance (CANH or CANL) to ground	TXD at 3 V, AB at 0 V, LBK at 0 V, EN at V _{CC}	20		50	kΩ	
I _{CC}	Supply current	Sleep	EN at 0 V, TXD at V _{CC} , RS at 0 V or V _{CC}	0.05	2	μA	
		Standby	RS at V _{CC} , TXD at V _{CC} , AB at 0 V, LBK at 0 V, EN at V _{CC}	200	600		
		Dominant	TXD at 0 V, no load, RS at 0 V, LBK at 0 V, AB at 0 V, EN at V _{CC}			6	mA
		Recessive	TXD at V _{CC} , no load, RS at 0 V, LBK at 0 V, AB at 0 V, EN at V _{CC}			6	

(1) All typical values are at 25°C and with a 3.3-V supply.

8.7 Switching Characteristics: Driver

over operating ambient temperature range (unless otherwise noted)

PARAMETER		TEST CONDITIONS	MIN	TYP ⁽¹⁾	MAX	UNIT
t _{PLH}	Propagation delay time, low-to-high-level output	RS at 0 V, see Figure 15		35	85	ns
		RS with 10 kΩ to ground, see Figure 15		70	125	
		RS with 100 kΩ to ground, see Figure 15		500	870	
t _{PHL}	Propagation delay time, high-to-low-level output	RS at 0 V, see Figure 15		70	120	ns
		RS with 10 kΩ to ground, see Figure 15		130	180	
		RS with 100 kΩ to ground, see Figure 15		870	1200	
t _{sk(p)}	Pulse skew ((t _{PHL} – t _{PLH}))	RS at 0 V, see Figure 15		35		ns
		RS with 10 kΩ to ground, see Figure 15		60		
		RS with 100 kΩ to ground, see Figure 15		370		
t _r	Differential output signal rise time	RS at 0 V, see Figure 15	20		70	ns
		RS with 10 kΩ to ground, see Figure 15	30		135	
		RS with 100 kΩ to ground, see Figure 15	350		1400	
t _f	Differential output signal fall time	RS at 0 V, see Figure 15	20		70	ns
		RS with 10 kΩ to ground, see Figure 15	30		135	
		RS with 100 kΩ to ground, see Figure 15	350		1400	
t _{en(s)}	Enable time from standby to dominant	See Figure 19 and Figure 20		0.6	1.5	μs
t _{en(z)}	Enable time from sleep to dominant			1	5	μs

(1) All typical values are at 25°C and with a 3.3-V supply.

8.8 Switching Characteristics: Receiver

over operating ambient temperature range (unless otherwise noted)

PARAMETER		TEST CONDITIONS	MIN	TYP ⁽¹⁾	MAX	UNIT
t_{PLH}	Propagation delay time, CANH input low to RXD output high	See Figure 17		35	60	ns
t_{PHL}	Propagation delay time, CANH input high to RXD output low			35	60	ns
$t_{sk(p)}$	Pulse skew ($ t_{PHL} - t_{PLH} $)			7		ns
t_r	Output signal rise time			2	5	ns
t_f	Output signal fall time			2	5	ns

(1) All typical values are at 25°C and with a 3.3-V supply.

8.9 Switching Characteristics: Device

over operating ambient temperature range (unless otherwise noted)

PARAMETER		TEST CONDITIONS	MIN	TYP ⁽¹⁾	MAX	UNIT
$t_{(LBK)}$	Loopback delay, driver input to receiver output	'HVD233-Q1 See Figure 23		7.5	12	ns
$t_{(AB1)}$	Loopback delay, driver input to receiver output	'HVD235-Q1 See Figure 24		10	20	ns
$t_{(AB2)}$	Loopback delay, bus input to receiver output		See Figure 25		35	60
$t_{(loop1)}$	Total loop delay, driver input to receiver output, recessive to dominant	RS at 0 V, see Figure 22		70	135	ns
		RS with 10 k Ω to ground, see Figure 22		105	190	
		RS with 100 k Ω to ground, see Figure 22		535	1000	
$t_{(loop2)}$	Total loop delay, driver input to receiver output, dominant to recessive	RS at 0 V, see Figure 22		70	135	ns
		RS with 10 k Ω to ground, see Figure 22		105	190	
		RS with 100 k Ω to ground, see Figure 22		535	1000	

(1) All typical values are at 25°C and with a 3.3-V supply.

8.10 Typical Characteristics

RS = LBK = AB = 0 V; EN = V_{CC}

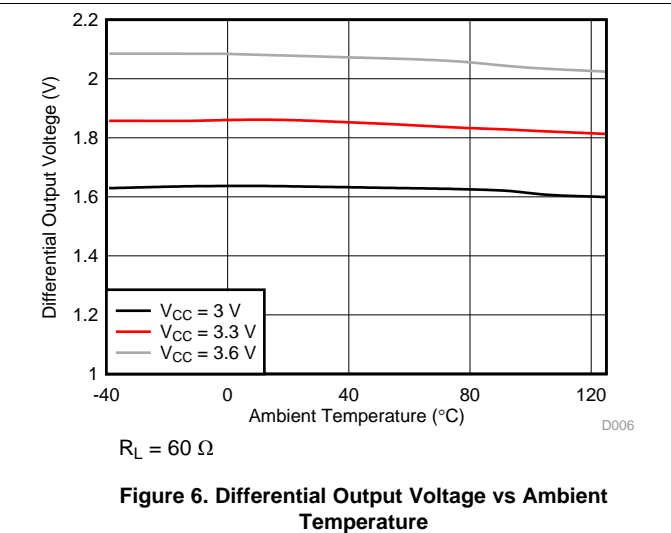
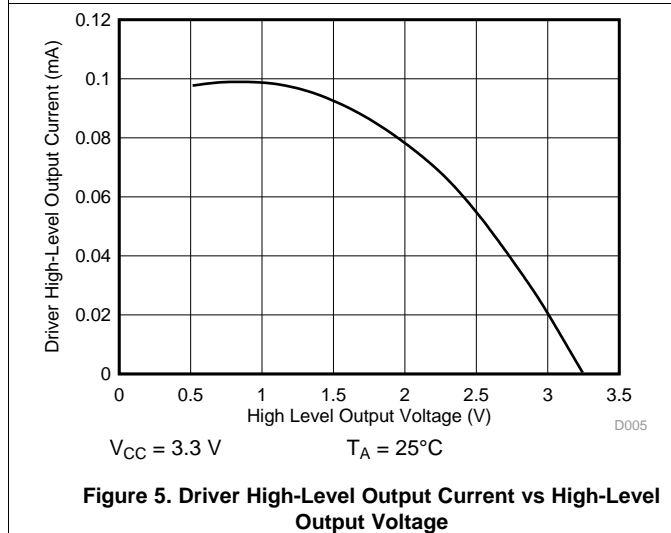
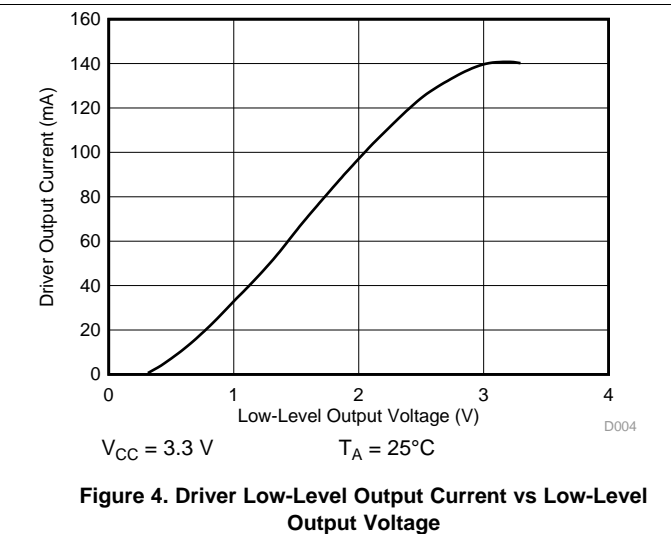
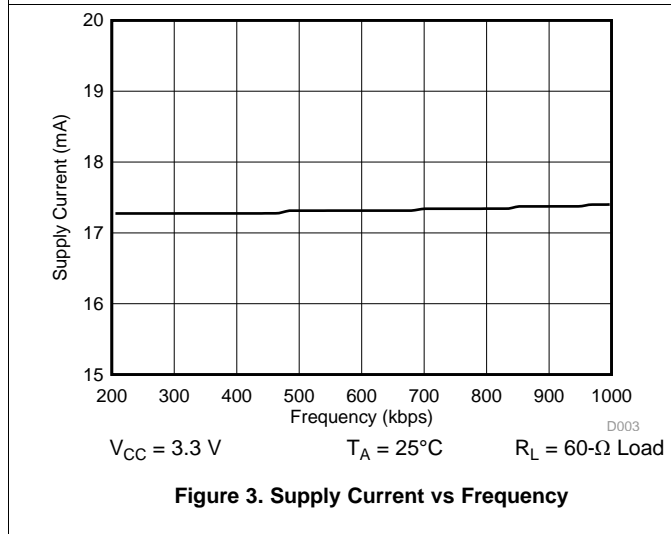
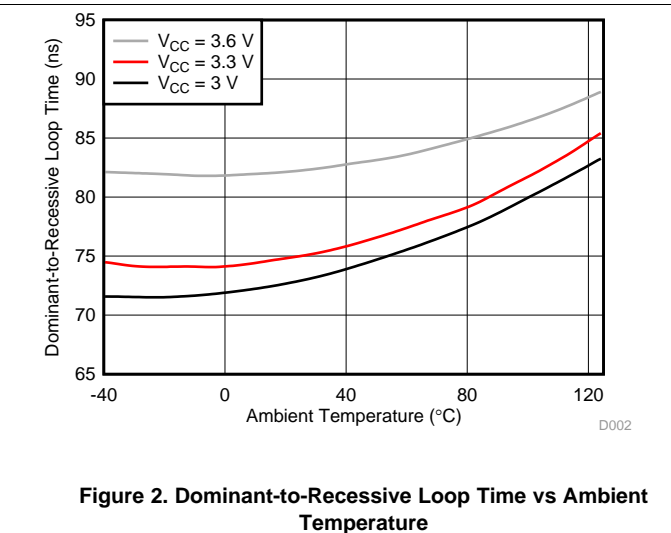
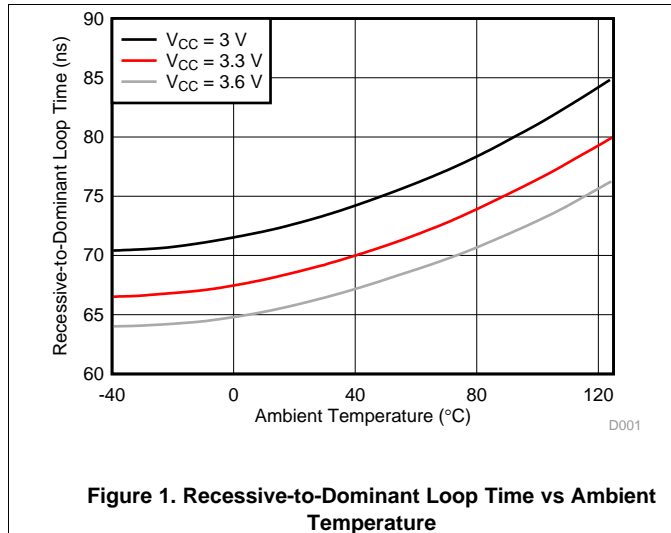

Typical Characteristics (continued)

RS = LBK = AB = 0 V; EN = V_{CC}

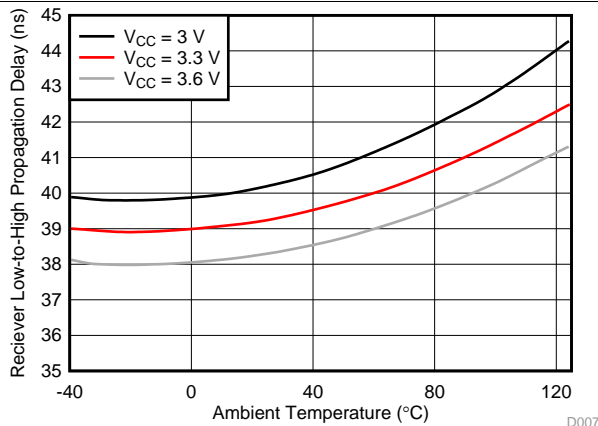

See Figure 3

Figure 7. Receiver Low-to-High Propagation Delay vs Ambient Temperature

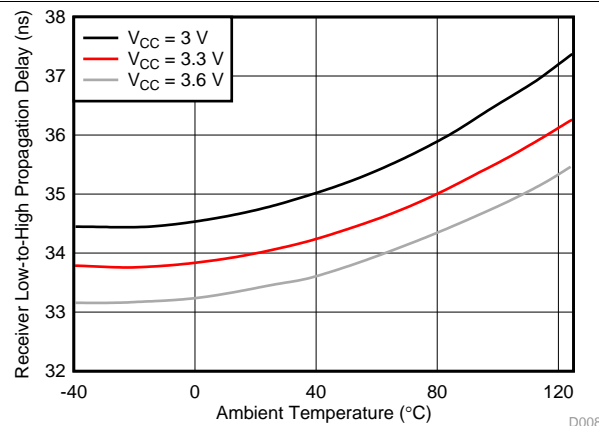

See Figure 3

Figure 8. Receiver High-to-Low Propagation Delay vs Ambient Temperature

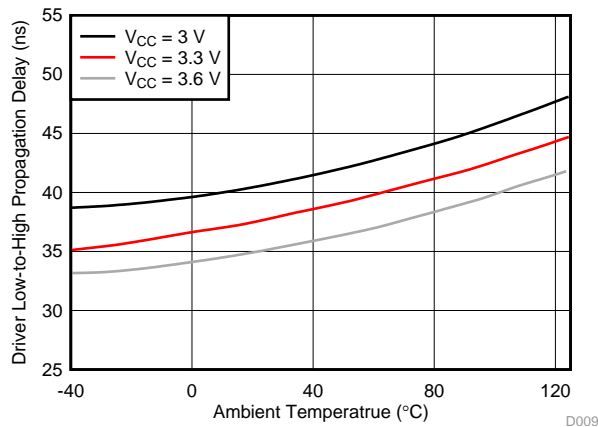

See Figure 1

Figure 9. Driver Low-to-High Propagation Delay vs Ambient Temperature

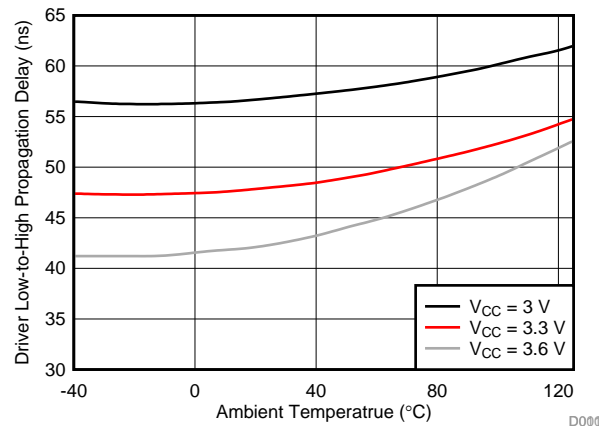

See Figure 1

Figure 10. Driver High-to-Low Propagation Delay vs Ambient Temperature

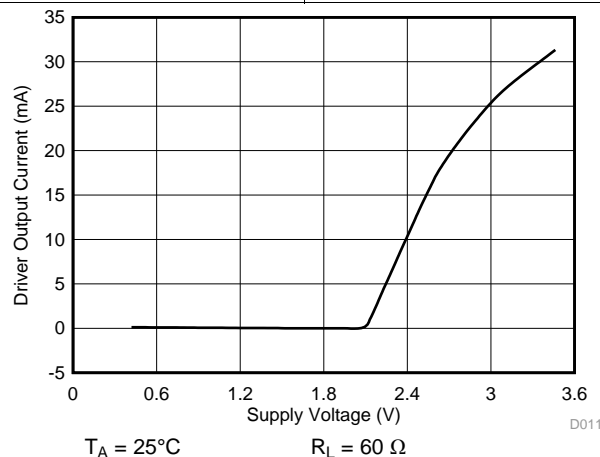

Figure 11. Driver Output Current vs Supply Voltage

9 Parameter Measurement Information

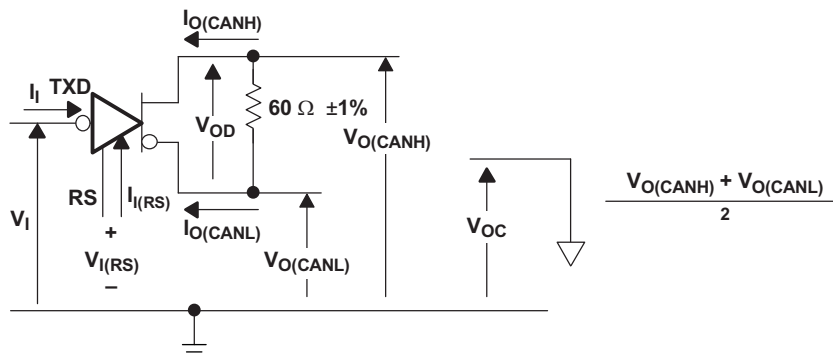

Figure 12. Driver Voltage, Current, and Test Definition

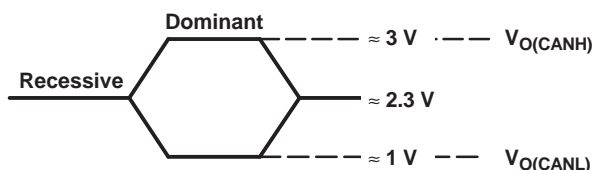

Figure 13. Bus Logic State Voltage Definitions

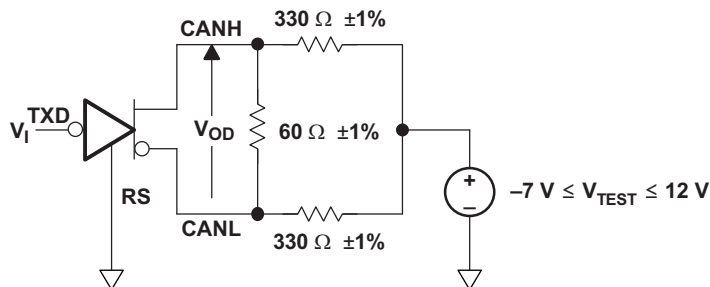
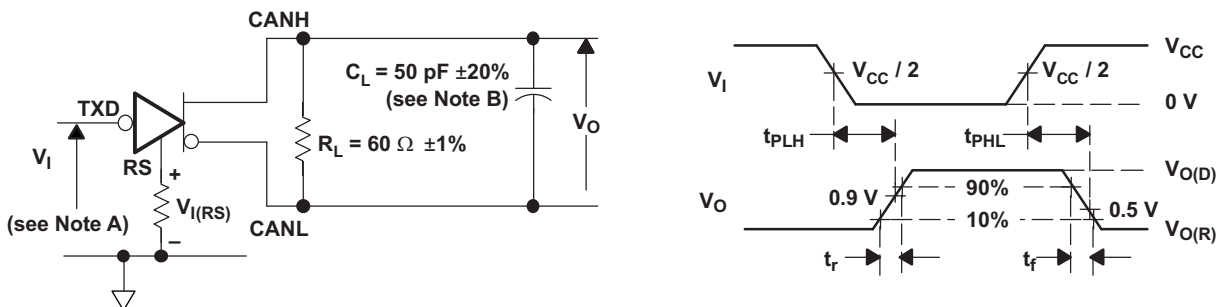

Figure 14. Driver V_{OD}



- The input pulse is supplied by a generator having the following characteristics: Pulse repetition rate (PRR) \leq 125 kHz, 50% duty cycle, $t_r \leq 6$ ns, $t_f \leq 6$ ns, $Z_O = 50 \Omega$.
- C_L includes fixture and instrumentation capacitance.

Figure 15. Driver Test Circuit and Voltage Waveforms

Parameter Measurement Information (continued)

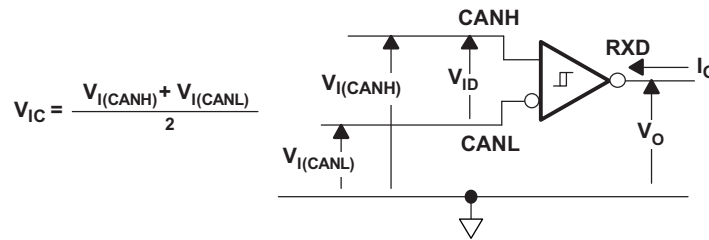
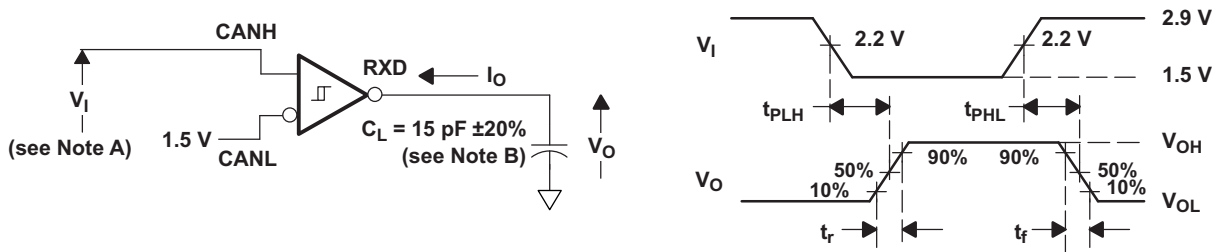

Figure 16. Receiver Voltage and Current Definitions



- A. The input pulse is supplied by a generator having the following characteristics: Pulse repetition rate (PRR) ≤ 125 kHz, 50% duty cycle, $t_r \leq 6$ ns, $t_f \leq 6$ ns, $Z_O = 50 \Omega$.
- B. C_L includes fixture and instrumentation capacitance.

Figure 17. Receiver Test Circuit and Voltage Waveforms

Table 1. Differential Input Voltage Threshold Test

INPUT		OUTPUT	MEASURED	
V_{CANH}	V_{CANL}	RXD	$ V_{ID} $	
-6.1 V	-7 V	L	V _{OL}	900 mV
12 V	11.1 V	L		900 mV
-1 V	-7 V	L		6 V
12 V	6 V	L		6 V
-6.5 V	-7 V	H	V _{OH}	500 mV
12 V	11.5 V	H		500 mV
-7 V	-1 V	H		6 V
6 V	12 V	H		6 V
Open	Open	H		X

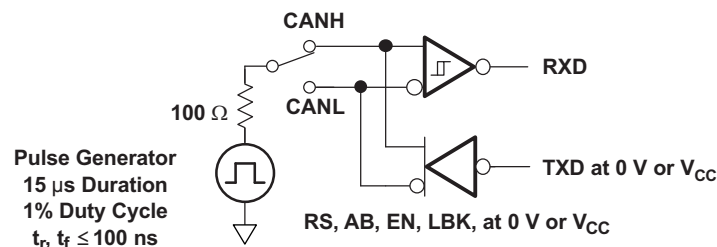

NOTE: This test is conducted to test survivability only. Data stability at the RXD output is not specified.

Figure 18. Test Circuit, Transient Overvoltage Test

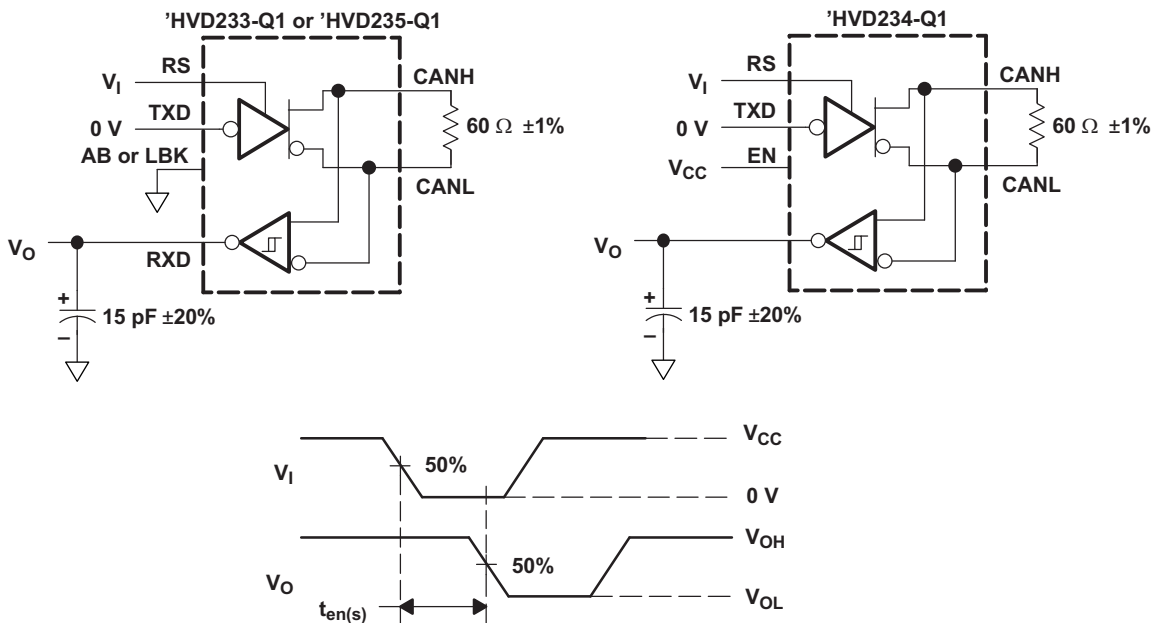

Copyright © 2016, Texas Instruments Incorporated

NOTE: All V_1 input pulses are supplied by a generator having the following characteristics: t_r or $t_f \leq 6$ ns, pulse repetition rate (PRR) = 125 kHz, 50% duty cycle.

Figure 19. $t_{en(s)}$ Test Circuit and Voltage Waveforms

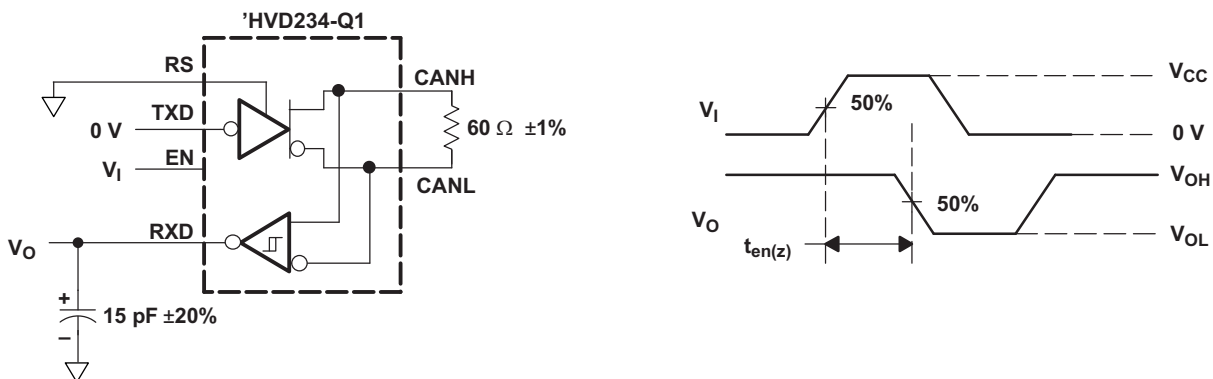

NOTE: All V_1 input pulses are supplied by a generator having the following characteristics: t_r or $t_f \leq 6$ ns, pulse repetition rate (PRR) = 50 kHz, 50% duty cycle.

Copyright © 2016, Texas Instruments Incorporated

Figure 20. $t_{en(z)}$ Test Circuit and Voltage Waveforms

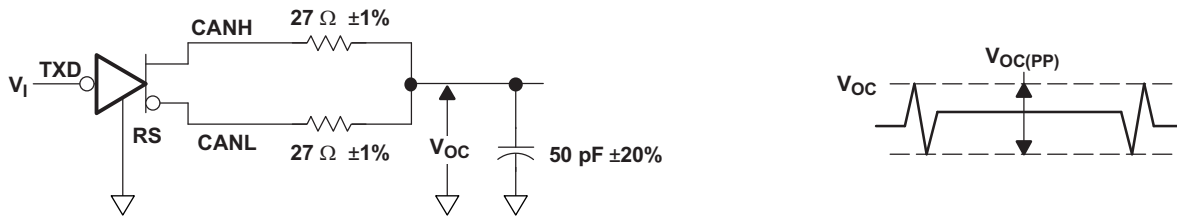

NOTE: All V_1 input pulses are supplied by a generator having the following characteristics: t_r or $t_f \leq 6$ ns, pulse repetition rate (PRR) = 125 kHz, 50% duty cycle.

Figure 21. $V_{OC(pp)}$ Test Circuit and Voltage Waveforms

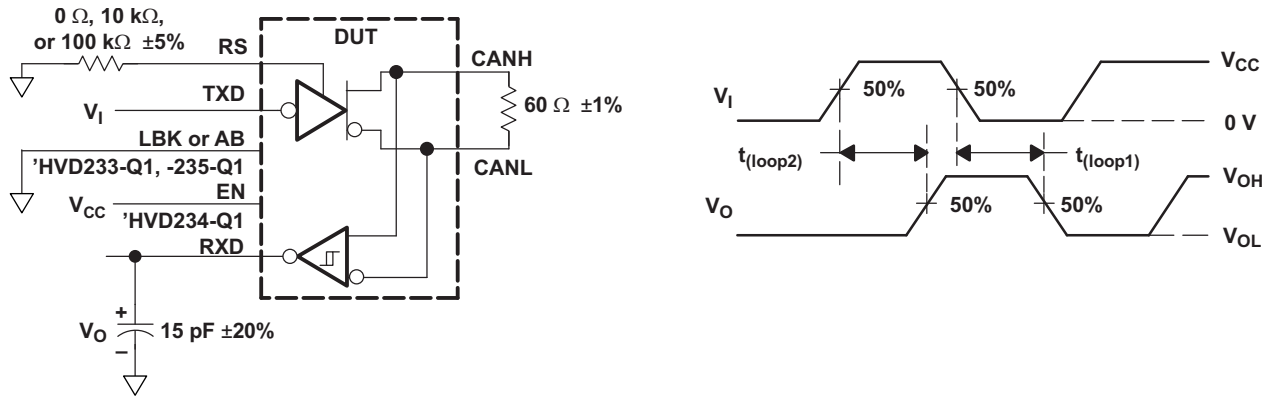

NOTE: All V_I input pulses are supplied by a generator having the following characteristics:
 t_r or $t_f \leq 6$ ns, pulse repetition rate (PRR) = 125 kHz, 50% duty cycle.

Copyright © 2016, Texas Instruments Incorporated

Figure 22. $t_{(loop)}$ Test Circuit and Voltage Waveforms

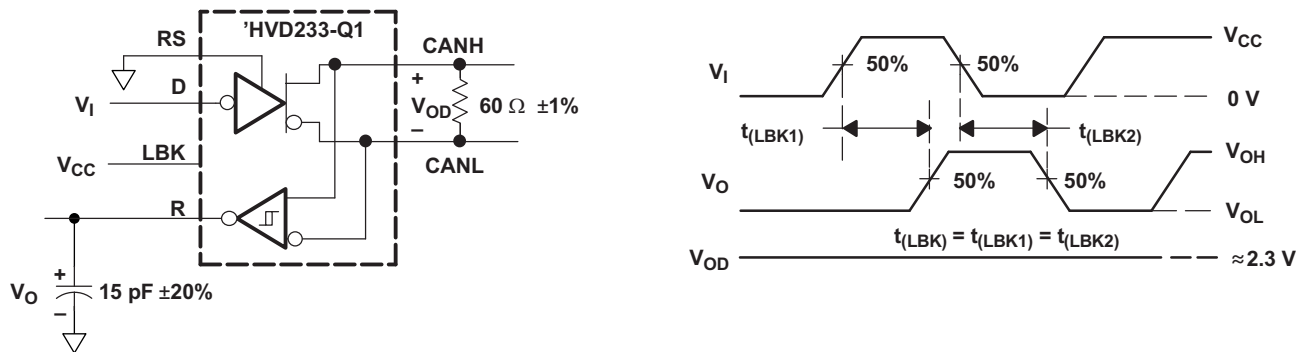

NOTE: All V_I input pulses are supplied by a generator having the following characteristics:
 t_r or $t_f \leq 6$ ns, pulse repetition rate (PRR) = 125 kHz, 50% duty cycle.

Copyright © 2016, Texas Instruments Incorporated

Figure 23. $t_{(LBK)}$ Test Circuit and Voltage Waveforms

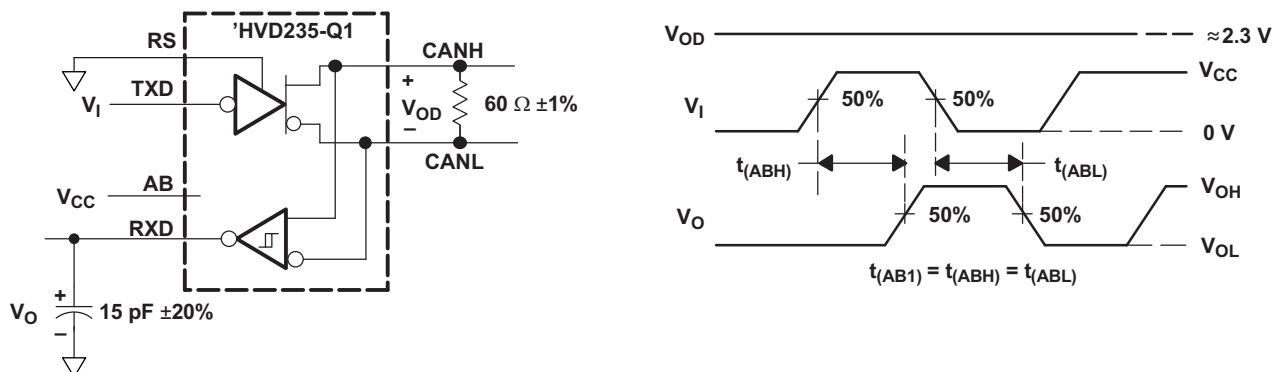

NOTE: All V_I input pulses are supplied by a generator having the following characteristics:
 t_r or $t_f \leq 6$ ns, pulse repetition rate (PRR) = 125 kHz, 50% duty cycle.

Copyright © 2016, Texas Instruments Incorporated

Figure 24. $t_{(AB1)}$ Test Circuit and Voltage Waveforms

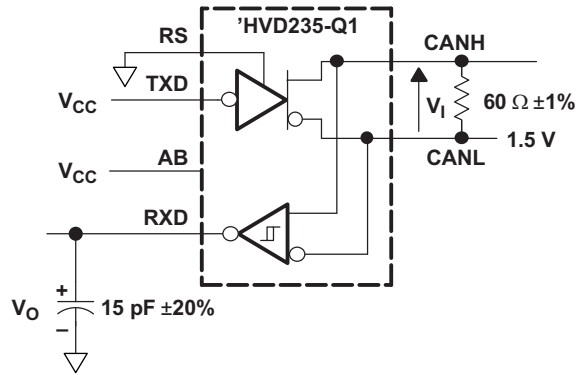

NOTE: All V_I input pulses are supplied by a generator having the following characteristics:
 t_r or $t_f \leq 6$ ns, pulse repetition rate (PRR) = 125 kHz, 50% duty cycle.

Copyright © 2016, Texas Instruments Incorporated

Figure 25. $t_{(AB2)}$ Test Circuit and Voltage Waveforms

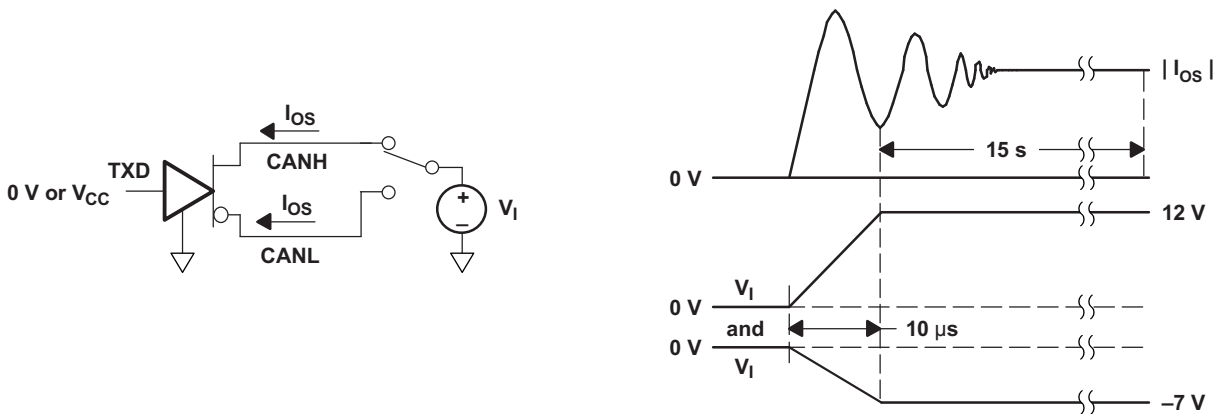
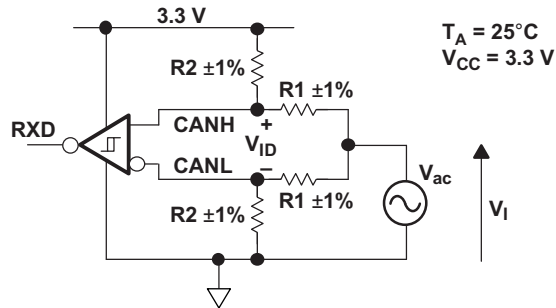

Figure 26. I_{OS} Test Circuit and Waveforms



The RXD Output State Does Not Change During Application of the Input Waveform.

V_{ID}	R1	R2
500 mV	50 Ω	280 Ω
900 mV	50 Ω	130 Ω



NOTE: All input pulses are supplied by a generator with $f \leq 1.5\text{ MHz}$.

Figure 27. Common-Mode Voltage Rejection

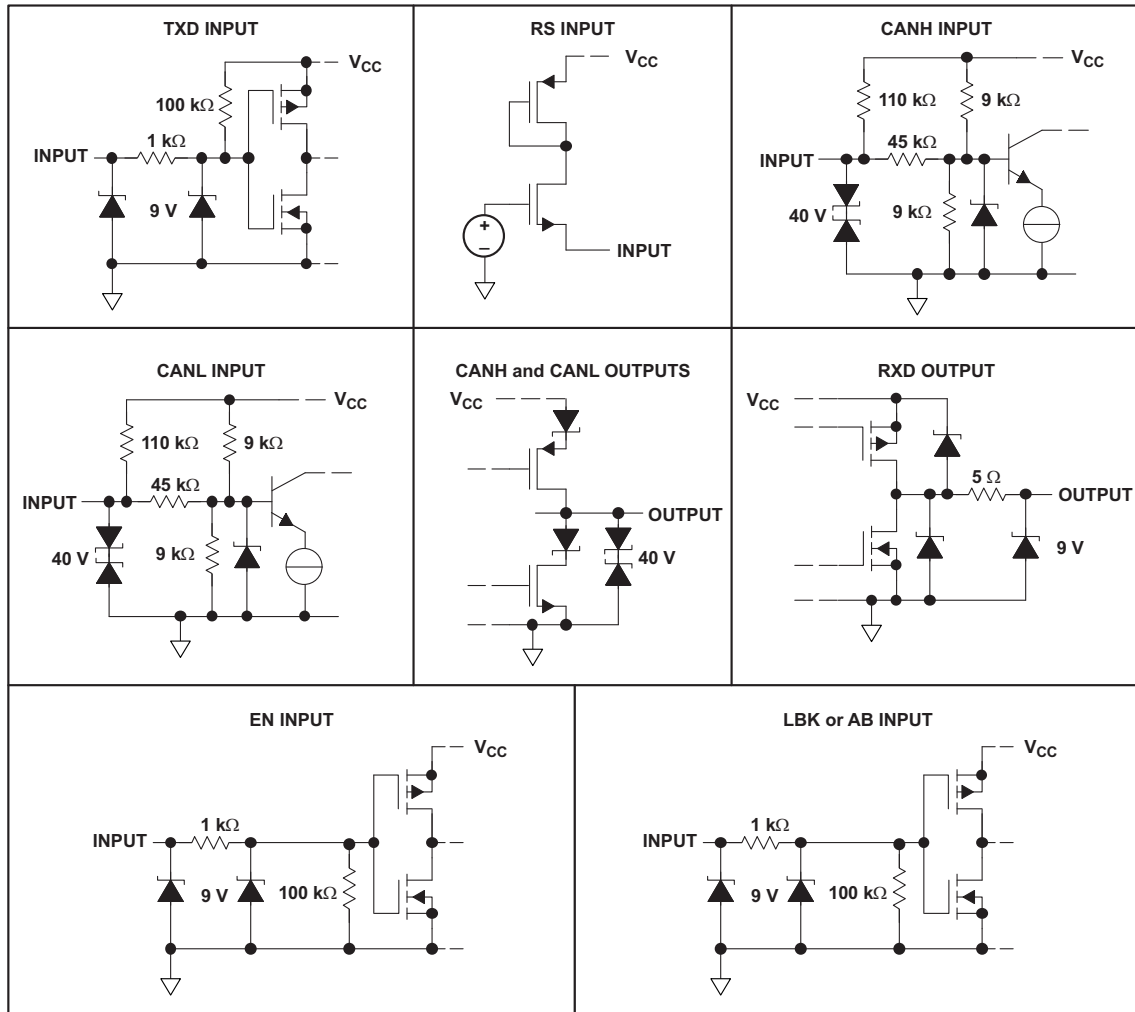

Figure 28. Equivalent Input and Output Schematic Diagrams

10 Detailed Description

10.1 Overview

This family of CAN transceivers is compatible with the ISO 11898-2 high-speed controller-area-network (CAN) physical layer standard. These devices are designed to interface between the differential bus lines in CAN and the CAN protocol controller at data rates up to 1 Mbps.

10.2 Functional Block Diagrams

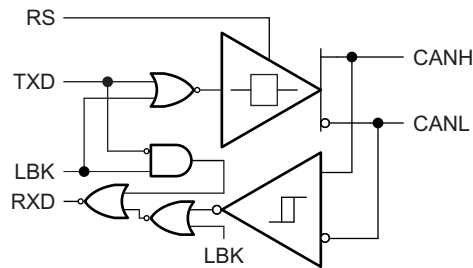

Figure 29. SN65HVD233-Q1 Functional Block Diagram

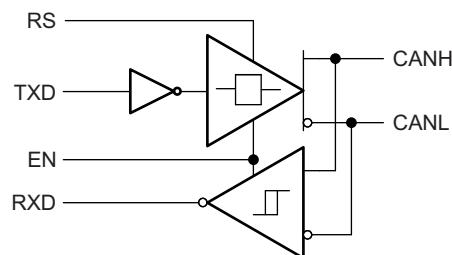

Figure 30. SN65HVD234-Q1 Functional Block Diagram

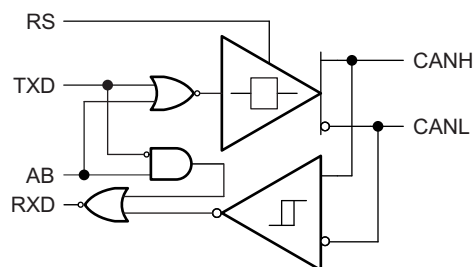

Figure 31. SN65HVD235-Q1 Functional Block Diagram

10.3 Feature Description

10.3.1 Diagnostic Loopback (SN65HVD233-Q1)

The diagnostic loopback or internal loopback function of the SN65HVD233-Q1 device is enabled with a high-level input on pin 5, LBK. This mode disables the driver output while keeping the bus pins biased to the recessive state. This mode also redirects the TXD data input (transmit data) through logic to the received data output pin, thus creating an internal loopback of the transmit-to-receive data path. This mimics the loopback that occurs normally with a CAN transceiver, because the receiver loops back the driven output to the RXD (receive data) pin. This mode allows the host protocol controller to input and read back a bit sequence or CAN messages to perform diagnostic routines without disturbing the CAN bus. A typical CAN bus application is displayed in [Figure 37](#).

Feature Description (continued)

If the LBK pin is not used, it may be tied to ground (GND). However, it is pulled low internally (defaults to a low-level input) and may be left open if not in use.

10.3.2 Autobaud Loopback (SN65HVD235-Q1)

The autobaud loopback mode of the SN65HVD235-Q1 device is enabled by placing a high-level input on pin 5, AB. In autobaud mode, the driver output is disabled, thus blocking the TXD pin-to-bus path and the bus transmit function of the transceiver. The bus pins remain biased to recessive. The receiver-to-RXD pin path of the device remains operational, allowing bus activity to be monitored. In addition, the autobaud mode includes an internal logic loopback path from the TXD pin to the RXD pin so the local node can transmit to itself in sync with bus traffic while not disturbing messages on the bus. Thus if the CAN controller of the local node generates an error frame, it is not transmitted to the bus, but is detected only by the local CAN controller. This is especially helpful to determine if the local node is set to the same baud rate as the network, and if not, to adjust it to the network baud rate (autobaud detection).

Autobaud detection is best suited to applications that have a known selection of baud rates. For example, if an application has optional settings of 125 kbps, 250 kbps, or 500 kbps. Once the SN65HVD235-Q1 device is placed into autobaud loopback mode, the application software could assume the first baud rate of 125 kbps. It then waits for a message to be transmitted by another node on the bus. If the wrong baud rate has been selected, an error message is generated by the local CAN controller because the sample times will not be at the correct time. However, because the bus-transmit function of the device has been disabled, no other nodes receive the error frame generated by the local CAN controller of this node.

The application would then make use of the status register indications of the local CAN controller for message-received and error-warning status to determine if the set baud rate is correct or not. The warning status indicates that the CAN controller error counters have been incremented. A message received status indicates that a good message has been received. If an error is generated, the application then sets the CAN controller to the next possibly valid baud rate, and waits to receive another message. This pattern is repeated until an error-free message has been received, thus the correct baud rate has been selected. At this point, the application places the SN65HVD235-Q1 device in a normal transmitting mode by setting pin 5 to a low level, thus enabling bus-transmit and bus-receive functions to normal operating states for the transceiver.

If the AB pin is not used, it may be tied to ground (GND). However, it is pulled low internally (defaults to a low-level input) and may be left open if not in use.

10.3.3 Slope Control

The rise and fall slope of the SN65HVD233-Q1, SN65HVD234-Q1, and SN65HVD235-Q1 driver output can be adjusted by connecting a resistor from RS (pin 8) to ground (GND) as shown in Figure 32, or to a low level input voltage as shown in Figure 33.

The slope of the driver output signal is proportional to the output current of the pin. This slope control is implemented with an external resistor value of 10 kΩ to achieve an approximately 15-V/μs slew rate, and up to 100 kΩ to achieve an approximately 2-V/μs slew rate. A typical slew-rate versus pulldown-resistance graph is shown in Figure 34. Typical driver output waveforms with slope control are displayed in Figure 40.

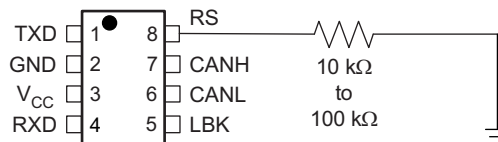

Figure 32. Ground Connection for Selecting Slope-Control or Standby Mode

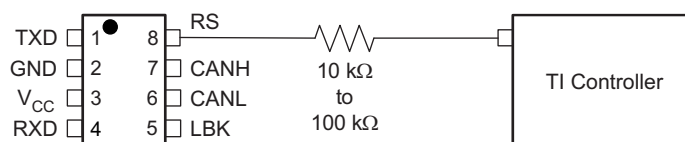

Figure 33. DSP Connection for Selecting Slope-Control or Standby Mode

Feature Description (continued)

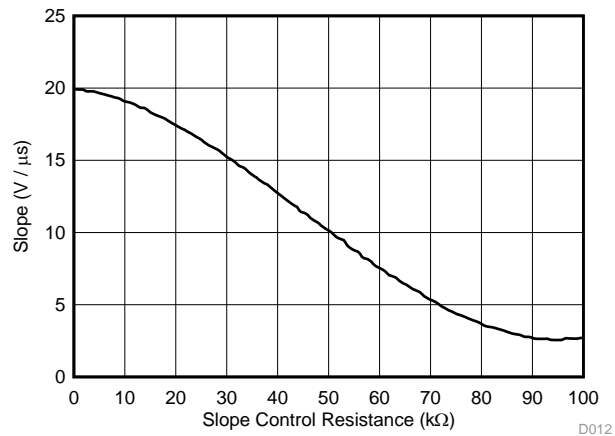

Figure 34. SN65HVD233-Q1 Driver Output-Signal Slope vs Slope-Control Resistance Value

10.3.4 Standby

If a high-level input ($> 0.75 V_{CC}$) is applied to RS (pin 8), the circuit enters a low-current, *listen only* standby mode during which the driver is switched off and the receiver remains active. If using this mode to save system power while waiting for bus traffic, the local controller can monitor the RXD output pin for a falling edge which indicates that a dominant signal was driven onto the CAN bus. The local controller can then drive the RS pin low to return to slope-control mode or high-speed mode.

10.3.5 Thermal Shutdown

If the junction temperature of the device exceeds the thermal shutdown threshold, the device turns off the CAN driver circuits, thus blocking the TXD pin-to-bus transmission path. The shutdown condition is cleared when the junction temperature drops sufficiently below the thermal shutdown temperature of the device. The CAN bus pins are high-impedance and biased to the recessive level during a thermal shutdown, and the receiver-to-RXD pin path remains operational.

10.4 Device Functional Modes

Table 2. Driver (SN65HVD233-Q1 or SN65HVD235-Q1)

INPUTS			OUTPUTS		
TXD	LBK or AB	RS	CANH	CANL	BUS STATE
X	X	$> 0.75 V_{CC}$	Z	Z	Recessive
L	L or open	$\leq 0.33 V_{CC}$	H	L	Dominant
H or open	X		Z	Z	Recessive
X	H	$\leq 0.33 V_{CC}$	Z	Z	Recessive

Table 3. Driver (SN65HVD234-Q1)

INPUTS			OUTPUTS		
TXD	EN	RS	CANH	CANL	BUS STATE
L	H	$\leq 0.33 V_{CC}$	H	L	Dominant
H	X	$\leq 0.33 V_{CC}$	Z	Z	Recessive
Open	X	X	Z	Z	Recessive
X	X	$> 0.75 V_{CC}$	Z	Z	Recessive
X	L or open	X	Z	Z	Recessive

Table 4. Receiver (SN65HVD233-Q1)⁽¹⁾

INPUTS				OUTPUT
BUS STATE	$V_{ID} = V_{(CANH)} - V_{(CANL)}$	LBK	TXD	RXD
Dominant	$V_{ID} \geq 0.9\text{ V}$	L or open	X	L
Recessive	$V_{ID} \leq 0.5\text{ V}$ or open	L or open	H or open	H
?	$0.5\text{ V} < V_{ID} < 0.9\text{ V}$	L or open	H or open	?
X	X	H	L	L
X	X	H	H	H

(1) H = high level; L = low level; Z = high impedance; X = irrelevant; ? = indeterminate

Table 5. Receiver (SN65HVD235-Q1)⁽¹⁾

INPUTS				OUTPUT
BUS STATE	$V_{ID} = V_{(CANH)} - V_{(CANL)}$	AB	TXD	RXD
Dominant	$V_{ID} \geq 0.9\text{ V}$	L or open	X	L
Recessive	$V_{ID} \leq 0.5\text{ V}$ or open	L or open	H or open	H
?	$0.5\text{ V} < V_{ID} < 0.9\text{ V}$	L or open	H or open	?
Dominant	$V_{ID} \geq 0.9\text{ V}$	H	X	L
Recessive	$V_{ID} \leq 0.5\text{ V}$ or open	H	H	H
Recessive	$V_{ID} \leq 0.5\text{ V}$ or open	H	L	L
?	$0.5\text{ V} < V_{ID} < 0.9\text{ V}$	H	L	L

(1) H = high level; L = low level; Z = high impedance; X = irrelevant; ? = indeterminate

Table 6. Receiver (SN65HVD234-Q1)⁽¹⁾

INPUTS			OUTPUT
BUS STATE	$V_{ID} = V_{(CANH)} - V_{(CANL)}$	EN	RXD
Dominant	$V_{ID} \geq 0.9\text{ V}$	H	L
Recessive	$V_{ID} \leq 0.5\text{ V}$ or open	H	H
?	$0.5\text{ V} < V_{ID} < 0.9\text{ V}$	H	?
X	X	L or open	H

(1) H = high level; L = low level; Z = high impedance; X = irrelevant; ? = indeterminate

11 Application and Implementation

NOTE

Information in the following applications sections is not part of the TI component specification, and TI does not warrant its accuracy or completeness. TI's customers are responsible for determining suitability of components for their purposes. Customers should validate and test their design implementation to confirm system functionality.

11.1 Application Information

The CAN bus has two states during powered operation of the device, *dominant* and *recessive*. A dominant bus state is when the bus is driven differentially, corresponding to a logic low on the TXD and RXD pins. A recessive bus state is when the bus is biased to $V_{CC} / 2$ via the high-resistance internal resistors R_{IN} and R_{ID} of the receiver, corresponding to a logic high on the TXD and RXD pins. See [Figure 35](#) and [Figure 36](#).

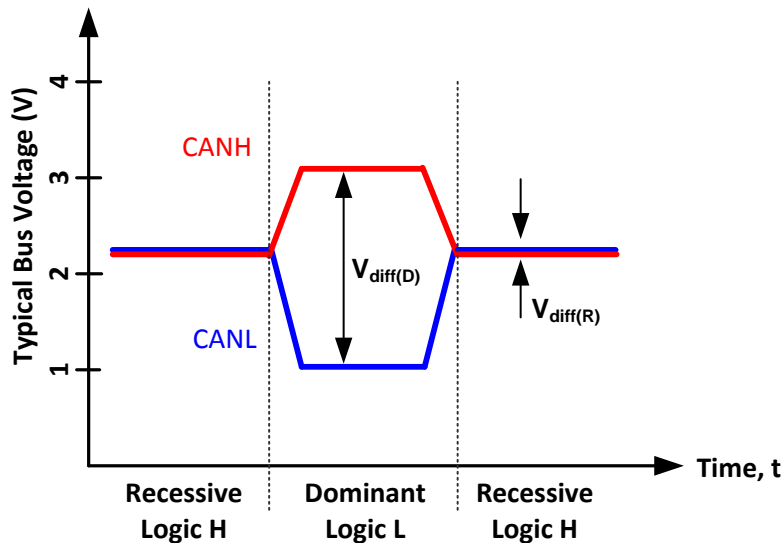

Figure 35. Bus States (Physical Bit Representation)

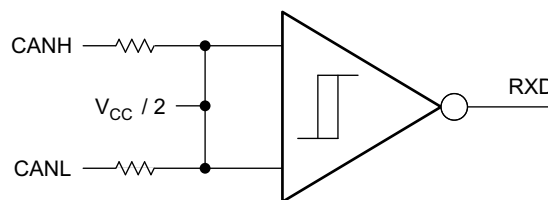
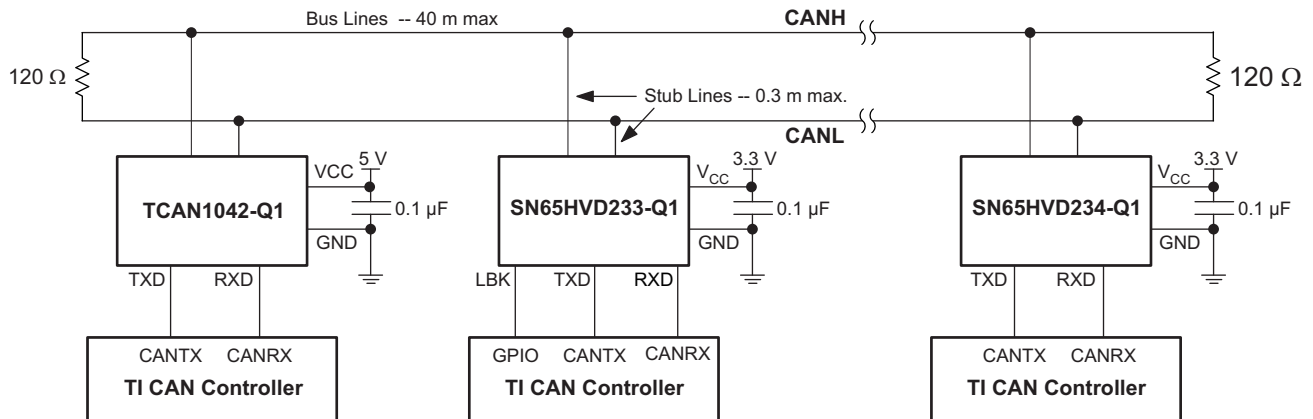

Figure 36. Simplified Recessive Common-Mode Bias and Receiver

These CAN transceivers are typically used in applications with a host microprocessor or FPGA that includes the link layer portion of the CAN protocol. The different nodes on the network are typically connected through the use of a 120- Ω characteristic impedance twisted-pair cable with termination on both ends of the bus.

11.2 Typical Application



Copyright © 2016, Texas Instruments Incorporated

Figure 37. Typical SN65HVD233-Q1 Application

11.2.1 Design Requirements

11.2.1.1 Bus Loading, Length and Number of Nodes

The ISO 11898 standard specifies a data rate of up to 1 Mbps, maximum CAN bus cable length of 40 m, maximum drop line (stub) length of 0.3 m and a maximum of 30 nodes. However, with careful network design, the system may have longer cables, longer stub lengths, and many more nodes to a bus. Many CAN organizations and standards have scaled the use of CAN for applications outside the original ISO 11898 standard. They have made system-level trade-offs for data rate, cable length, and parasitic loading of the bus. Examples of some of these specifications are ARINC825, CANopen, CAN Kingdom, DeviceNet and NMEA200.

A high number of nodes requires a transceiver with high input impedance and wide common-mode range, such as the SN65HVD23x-Q1 CAN family. ISO 11898-2 specifies the driver differential output with a 60-Ω load (two 120-Ω termination resistors in parallel) and the differential output must be greater than 1.5 V. The SN65HVD23x-Q1 devices are specified to meet the 1.5-V requirement with a 60-Ω load, and additionally specified with a differential output voltage minimum of 1.2 V across a common mode range of –2 V to 7 V through a 330-Ω coupling network. This network represents the bus loading of 120 SN65HVD23x-Q1 transceivers based on their minimum differential input resistance of 40 kΩ. Therefore, the SN65HVD23x-Q1 devices support up to 120 transceivers on a single bus segment with margin to the 1.2-V minimum differential input-voltage requirement at each node.

For CAN network design, margin must be given for signal loss across the system and cabling, parasitic loadings, network imbalances, ground offsets and signal integrity. Thus, a practical maximum number of nodes may be lower. Bus length may also be extended beyond the original ISO 11898 standard of 40 m by careful system-design and data-rate tradeoffs. For example, CANopen network design guidelines allow the network to be up to 1 km with changes in the termination resistance, cabling, fewer than 64 nodes, and significantly lowered data rate.

This flexibility in CAN network design is one of the key strengths of the various extensions and additional standards that have been built on the original ISO 11898 CAN standard.

11.2.1.2 CAN Termination

The ISO 11898 standard specifies the interconnect to be a twisted-pair cable (shielded or unshielded) with 120-Ω characteristic impedance (Z_0). Resistors equal to the characteristic impedance of the line should be used to terminate both ends of the cable to prevent signal reflections. Unterminated drop lines (stubs) connecting nodes to the bus should be kept as short as possible to minimize signal reflections. The termination may be on the cable or in a node, but if nodes may be removed from the bus the termination must be carefully placed so that it is not removed from the bus.

Typical Application (continued)

11.2.2 Detailed Design Procedure

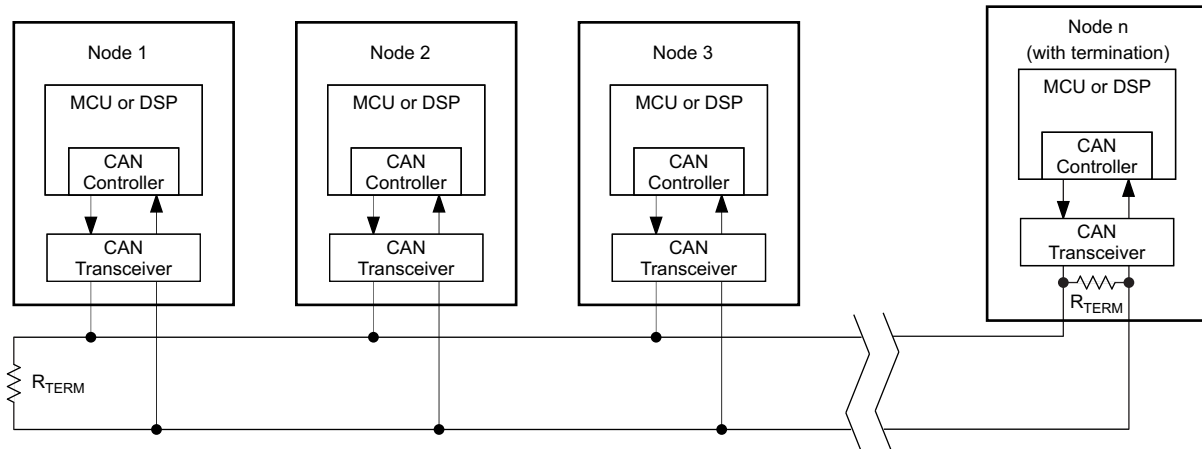

Figure 38. Typical CAN Bus

Termination is typically a 120-Ω resistor at each end of the bus. If filtering and stabilization of the common-mode voltage of the bus is desired, then split termination may be used (see [Figure 39](#)). Split termination uses two 60-Ω resistors with a capacitor in the middle of these resistors to ground. Split termination improves the electromagnetic emissions behavior of the network by eliminating fluctuations in the bus common-mode voltages at the start and end of message transmissions.

Care should be taken in the power ratings of the termination resistors used. Typically, the worst-case condition would be if the system power supply is shorted across the termination resistance to ground. In most cases, the current flow through the resistor in this condition would be much higher than the transceiver current limit.

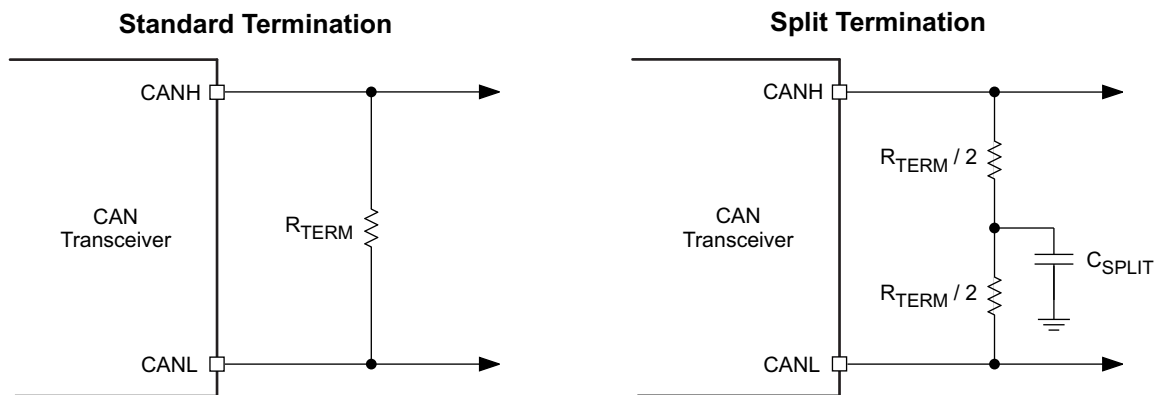

Figure 39. CAN Bus Termination Concepts

11.2.3 Application Curve

[Figure 40](#) shows three typical output waveforms for the SN65HVD233-Q1 device with three different connections made to the RS pin. The top waveform shows the typical differential signal when transitioning from a recessive level to a dominant level on the CAN bus with RS tied to GND through a 0-Ω resistor. The second waveform shows the same signal for the condition with a 10-kΩ resistor tied from RS to ground. The bottom waveform shows the typical differential signal for the case where a 100-kΩ resistor is tied from the RS pin to ground.

Typical Application (continued)

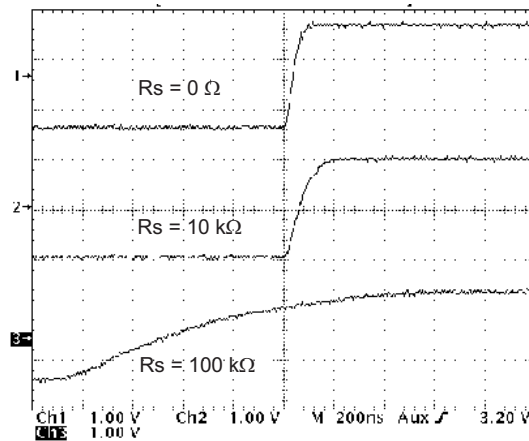

Figure 40. Typical SN65HVD233-Q1 Output Waveforms With Different Slope-Control Resistor Values

11.3 System Example

11.3.1 ISO 11898 Compliance of SN65HVD23x-Q1 Family of 3.3-V CAN Transceivers

11.3.1.1 Introduction

Many users value the low power consumption of operating their CAN transceivers from a 3.3-V supply. However, some are concerned about the interoperability with 5-V-supplied transceivers on the same bus. This report analyzes this situation to address those concerns.

11.3.1.2 Differential Signal

CAN is a differential bus where complementary signals are sent over two wires and the voltage difference between the two wires defines the logical state of the bus. The differential CAN receiver monitors this voltage difference and outputs the bus state with a single-ended logic-level output signal.

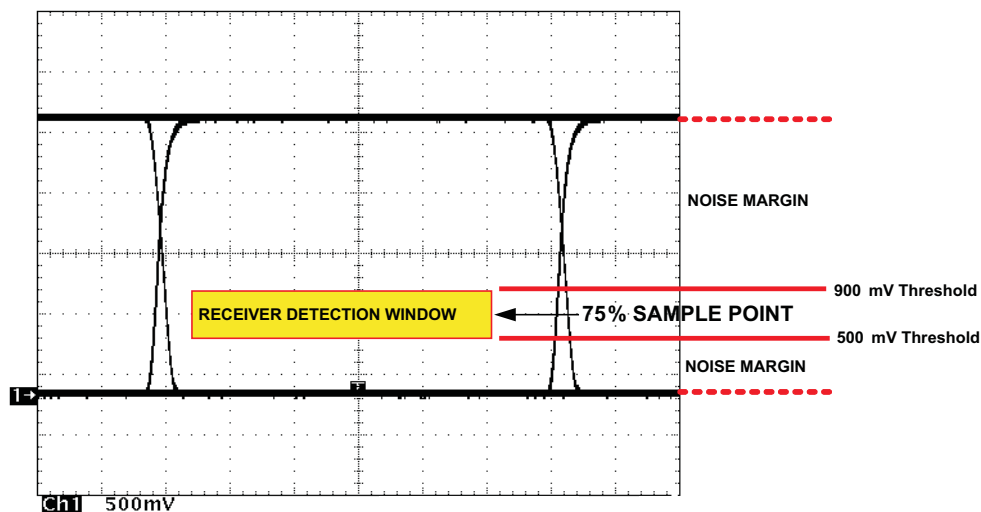

Figure 41. Typical Differential-Output-Voltage Waveform

System Example (continued)

The CAN driver creates the differential voltage between CANH and CANL in the dominant state. The dominant differential output of the SN65HVD23x-Q1 device is greater than 1.5 V and less than 3 V across a 60- Ω load as defined by the ISO 11898 standard. These are the same limiting values as for 5-V-supplied CAN transceivers. The bus termination resistors, and not the CAN driver, drive the bus to the recessive state.

A CAN receiver is required to output a recessive state when less than 500 mV of differential voltage exists on the bus, and a dominant state when more than 900 mV of differential voltage exists on the bus. The CAN receiver must do this with common-mode input voltages from -2 V to 7 V. The SN65HVD23x-Q1 family of receivers meets these same input specifications as 5-V-supplied receivers do.

11.3.1.3 Common-Mode Signal

The differential receiver rejects the common-mode signal, which is the average of the two CAN signals. The common-mode signal comes from the CAN driver, ground noise, and coupled bus noise. Because the bias voltage of the recessive state of the device is dependent on V_{CC} , any noise present or any variation of V_{CC} has an effect on this bias voltage seen by the bus. The SN65HVD23x-Q1 family has the recessive bias voltage set higher than $0.5 \times V_{CC}$ to comply with the ISO 11898-2 CAN standard. The caveat to this is that the common-mode voltage drops by a approximately 200 millivolts when driving a dominant bit on the bus. This means that there is a common-mode shift between the dominant-bit and recessive-bit states of the device. Although this is not ideal, this small variation in the driver common-mode output is rejected by differential receivers and does not affect data, signal noise margins, or error rates.

11.3.1.4 Interoperability of 3.3-V CAN in 5-V CAN Systems

The 3.3-V-supplied SN65HVD23x-Q1 family of CAN transceivers is fully compatible with 5-V CAN transceivers. The differential output voltage is the same, the recessive common-mode output bias is the same, and the receivers have the same input specifications. The only slight difference is in the dominant common-mode output voltage, which is approximately 200 millivolts lower for a 3.3-V CAN transceiver than for a 5-V-supplied transceiver.

To help ensure the widest interoperability possible, the SN65HVD23x-Q1 family has successfully passed the internationally recognized GIFT/ICT conformance and interoperability testing for CAN transceivers. Electrical interoperability does not always assure interchangeability, however. Most implementers of CAN buses recognize that ISO 11898 does not sufficiently specify the electrical layer and that strict standard compliance alone does not ensure full interchangeability. This comes only with thorough equipment testing.

12 Power Supply Recommendations

To ensure reliable operation at all data rates and supply voltages, each supply should be decoupled with a 100-nF ceramic capacitor located as close to the V_{CC} supply pins as possible. The TPS76333-Q1 is a linear voltage regulator suitable for the 3.3 V supply.

13 Layout

13.1 Layout Guidelines

In order for the PCB design to be successful, start with design of the protection and filtering circuitry. Because ESD and EFT transients have a wide frequency bandwidth from approximately 3 MHz to 3 GHz, high-frequency layout techniques must be applied during PCB design. On-chip IEC ESD protection is good for laboratory and portable equipment but is usually not sufficient for EFT and surge transients occurring in industrial environments. Therefore, robust and reliable bus node design requires the use of external transient protection devices at the bus connectors. Placement at the connector also prevents these harsh transient events from propagating further into the PCB and system.

Use V_{CC} and ground planes to provide low inductance.

Layout Guidelines (continued)

NOTE

High-frequency current follows the path of least inductance and not the path of least resistance.

Design bus protection by placing the protective components in the signal path. Do not force the transient current to divert from the signal path to reach the protection device.

An example placement of the transient-voltage-suppression (TVS) device indicated as D1 (either bidirectional diode or varistor solution) and bus filter capacitors C8 and C9 is shown in [Figure 42](#).

The bus transient protection and filtering components should be placed as close to the bus connector, J1, as possible. This prevents transients, ESD and noise from penetrating onto the board and disturbing other devices.

Bus termination: [Figure 42](#) shows split termination. This is where the termination is split into two resistors, R5 and R6, with the center or split tap of the termination connected to ground via capacitor C7. Split termination provides common-mode filtering for the bus. When termination is placed on the board instead of directly on the bus, care must be taken to ensure the terminating node is not removed from the bus, as there are signal integrity issues if the bus is not properly terminated on both ends. See the [Detailed Design Procedure](#) section for information on power ratings needed for the termination resistor(s).

Bypass and bulk capacitors should be placed as close as possible to the supply pins of the transceiver, as in the example of C2 and C3 on V_{CC} .

Use at least two vias for the V_{CC} and ground connections of the bypass capacitors and protection devices to minimize trace and via inductance.

To limit current on the digital lines, serial resistors may be used. Examples are R1, R2, R3 and R4.

To filter noise on the digital I/O lines, a capacitor may be used close to the input side of the I/O as shown by C1 and C4.

Because the internal pullup and pulldown biasing of the device is weak for floating pins, an external 1-k Ω to 10-k Ω pullup or pulldown resistor should be used to bias the state of the pin more strongly against noise during transient events.

Pin 1: If an open-drain host processor is used to drive the TXD pin of the device, an external pullup resistor between 1 k Ω and 10 k Ω to V_{CC} should be used to drive the recessive input state of the device.

Pin 8: The mode pin, RS, is shown, assuming that it is used in the application. If the device is only to be used in normal mode or slope-control mode, R3 is not needed and the pads of C4 could be used for the pulldown resistor to GND.

13.2 Layout Example

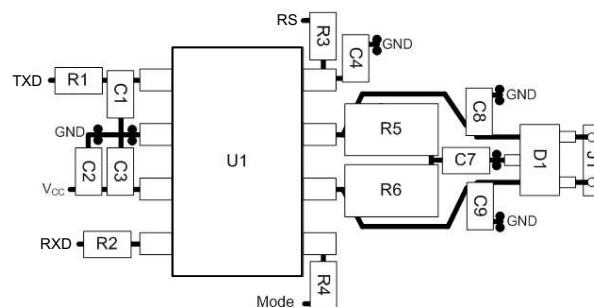

Figure 42. Layout Example Diagram

14 Device and Documentation Support

14.1 Related Links

The table below lists quick access links. Categories include technical documents, support and community resources, tools and software, and quick access to sample or buy.

Table 7. Related Links

PARTS	PRODUCT FOLDER	SAMPLE & BUY	TECHNICAL DOCUMENTS	TOOLS & SOFTWARE	SUPPORT & COMMUNITY
SN65HVD233-Q1	Click here	Click here	Click here	Click here	Click here
SN65HVD234-Q1	Click here	Click here	Click here	Click here	Click here
SN65HVD235-Q1	Click here	Click here	Click here	Click here	Click here

14.2 Receiving Notification of Documentation Updates

To receive notification of documentation updates, navigate to the device product folder on ti.com. In the upper right corner, click on *Alert me* to register and receive a weekly digest of any product information that has changed. For change details, review the revision history included in any revised document.

14.3 Community Resources

The following links connect to TI community resources. Linked contents are provided "AS IS" by the respective contributors. They do not constitute TI specifications and do not necessarily reflect TI's views; see TI's [Terms of Use](#).

TI E2E™ Online Community *TI's Engineer-to-Engineer (E2E) Community*. Created to foster collaboration among engineers. At e2e.ti.com, you can ask questions, share knowledge, explore ideas and help solve problems with fellow engineers.

Design Support *TI's Design Support* Quickly find helpful E2E forums along with design support tools and contact information for technical support.

14.4 Trademarks

E2E is a trademark of Texas Instruments.
All other trademarks are the property of their respective owners.

14.5 Electrostatic Discharge Caution



These devices have limited built-in ESD protection. The leads should be shorted together or the device placed in conductive foam during storage or handling to prevent electrostatic damage to the MOS gates.

14.6 Glossary

[SLYZ022](#) — *TI Glossary*.

This glossary lists and explains terms, acronyms, and definitions.

15 Mechanical, Packaging, and Orderable Information

The following pages include mechanical, packaging, and orderable information. This information is the most-current data available for the designated devices. This data is subject to change without notice and without revision of this document. For browser-based versions of this data sheet, see the left-hand navigation pane.

PACKAGING INFORMATION

Orderable part number	Status (1)	Material type (2)	Package Pins	Package qty Carrier	RoHS (3)	Lead finish/ Ball material (4)	MSL rating/ Peak reflow (5)	Op temp (°C)	Part marking (6)
SN65HVD233QDRQ1	Active	Production	SOIC (D) 8	2500 LARGE T&R	Yes	NIPDAU	Level-1-260C-UNLIM	-40 to 125	233Q
SN65HVD233QDRQ1.A	Active	Production	SOIC (D) 8	2500 LARGE T&R	Yes	NIPDAU	Level-1-260C-UNLIM	-40 to 125	233Q
SN65HVD234QDRQ1	Active	Production	SOIC (D) 8	2500 LARGE T&R	Yes	NIPDAU	Level-1-260C-UNLIM	-40 to 125	234Q
SN65HVD234QDRQ1.A	Active	Production	SOIC (D) 8	2500 LARGE T&R	Yes	NIPDAU	Level-1-260C-UNLIM	-40 to 125	234Q
SN65HVD235QDRQ1	Active	Production	SOIC (D) 8	2500 LARGE T&R	Yes	NIPDAU	Level-1-260C-UNLIM	-40 to 125	235Q
SN65HVD235QDRQ1.A	Active	Production	SOIC (D) 8	2500 LARGE T&R	Yes	NIPDAU	Level-1-260C-UNLIM	-40 to 125	235Q

(1) **Status:** For more details on status, see our [product life cycle](#).

(2) **Material type:** When designated, preproduction parts are prototypes/experimental devices, and are not yet approved or released for full production. Testing and final process, including without limitation quality assurance, reliability performance testing, and/or process qualification, may not yet be complete, and this item is subject to further changes or possible discontinuation. If available for ordering, purchases will be subject to an additional waiver at checkout, and are intended for early internal evaluation purposes only. These items are sold without warranties of any kind.

(3) **RoHS values:** Yes, No, RoHS Exempt. See the [TI RoHS Statement](#) for additional information and value definition.

(4) **Lead finish/Ball material:** Parts may have multiple material finish options. Finish options are separated by a vertical ruled line. Lead finish/Ball material values may wrap to two lines if the finish value exceeds the maximum column width.

(5) **MSL rating/Peak reflow:** The moisture sensitivity level ratings and peak solder (reflow) temperatures. In the event that a part has multiple moisture sensitivity ratings, only the lowest level per JEDEC standards is shown. Refer to the shipping label for the actual reflow temperature that will be used to mount the part to the printed circuit board.

(6) **Part marking:** There may be an additional marking, which relates to the logo, the lot trace code information, or the environmental category of the part.

Multiple part markings will be inside parentheses. Only one part marking contained in parentheses and separated by a "~" will appear on a part. If a line is indented then it is a continuation of the previous line and the two combined represent the entire part marking for that device.

Important Information and Disclaimer:The information provided on this page represents TI's knowledge and belief as of the date that it is provided. TI bases its knowledge and belief on information provided by third parties, and makes no representation or warranty as to the accuracy of such information. Efforts are underway to better integrate information from third parties. TI has taken and continues to take reasonable steps to provide representative and accurate information but may not have conducted destructive testing or chemical analysis on incoming materials and chemicals. TI and TI suppliers consider certain information to be proprietary, and thus CAS numbers and other limited information may not be available for release.

In no event shall TI's liability arising out of such information exceed the total purchase price of the TI part(s) at issue in this document sold by TI to Customer on an annual basis.

OTHER QUALIFIED VERSIONS OF SN65HVD233-Q1, SN65HVD234-Q1, SN65HVD235-Q1 :

- Catalog : [SN65HVD233](#), [SN65HVD234](#), [SN65HVD235](#)
- Enhanced Product : [SN65HVD233-EP](#)

NOTE: Qualified Version Definitions:

- Catalog - TI's standard catalog product
- Enhanced Product - Supports Defense, Aerospace and Medical Applications

TAPE AND REEL INFORMATION

QUADRANT ASSIGNMENTS FOR PIN 1 ORIENTATION IN TAPE

*All dimensions are nominal

Device	Package Type	Package Drawing	Pins	SPQ	Reel Diameter (mm)	Reel Width W1 (mm)	A0 (mm)	B0 (mm)	K0 (mm)	P1 (mm)	W (mm)	Pin1 Quadrant
SN65HVD233QDRQ1	SOIC	D	8	2500	330.0	12.4	6.4	5.2	2.1	8.0	12.0	Q1
SN65HVD234QDRQ1	SOIC	D	8	2500	330.0	12.4	6.4	5.2	2.1	8.0	12.0	Q1
SN65HVD235QDRQ1	SOIC	D	8	2500	330.0	12.4	6.4	5.2	2.1	8.0	12.0	Q1

TAPE AND REEL BOX DIMENSIONS

*All dimensions are nominal

Device	Package Type	Package Drawing	Pins	SPQ	Length (mm)	Width (mm)	Height (mm)
SN65HVD233QDRQ1	SOIC	D	8	2500	353.0	353.0	32.0
SN65HVD234QDRQ1	SOIC	D	8	2500	353.0	353.0	32.0
SN65HVD235QDRQ1	SOIC	D	8	2500	353.0	353.0	32.0



D0008A

PACKAGE OUTLINE

SOIC - 1.75 mm max height

SMALL OUTLINE INTEGRATED CIRCUIT



4214825/C 02/2019

NOTES:

- Linear dimensions are in inches [millimeters]. Dimensions in parenthesis are for reference only. Controlling dimensions are in inches. Dimensioning and tolerancing per ASME Y14.5M.
- This drawing is subject to change without notice.
- This dimension does not include mold flash, protrusions, or gate burrs. Mold flash, protrusions, or gate burrs shall not exceed .006 [0.15] per side.
- This dimension does not include interlead flash.
- Reference JEDEC registration MS-012, variation AA.

EXAMPLE BOARD LAYOUT

D0008A

SOIC - 1.75 mm max height

SMALL OUTLINE INTEGRATED CIRCUIT



LAND PATTERN EXAMPLE
 EXPOSED METAL SHOWN
 SCALE:8X



SOLDER MASK DETAILS

4214825/C 02/2019

NOTES: (continued)

- 6. Publication IPC-7351 may have alternate designs.
- 7. Solder mask tolerances between and around signal pads can vary based on board fabrication site.

EXAMPLE STENCIL DESIGN

D0008A

SOIC - 1.75 mm max height

SMALL OUTLINE INTEGRATED CIRCUIT



SOLDER PASTE EXAMPLE
BASED ON .005 INCH [0.125 MM] THICK STENCIL
SCALE:8X

4214825/C 02/2019

NOTES: (continued)

8. Laser cutting apertures with trapezoidal walls and rounded corners may offer better paste release. IPC-7525 may have alternate design recommendations.
9. Board assembly site may have different recommendations for stencil design.

IMPORTANT NOTICE AND DISCLAIMER

TI PROVIDES TECHNICAL AND RELIABILITY DATA (INCLUDING DATASHEETS), DESIGN RESOURCES (INCLUDING REFERENCE DESIGNS), APPLICATION OR OTHER DESIGN ADVICE, WEB TOOLS, SAFETY INFORMATION, AND OTHER RESOURCES "AS IS" AND WITH ALL FAULTS, AND DISCLAIMS ALL WARRANTIES, EXPRESS AND IMPLIED, INCLUDING WITHOUT LIMITATION ANY IMPLIED WARRANTIES OF MERCHANTABILITY, FITNESS FOR A PARTICULAR PURPOSE OR NON-INFRINGEMENT OF THIRD PARTY INTELLECTUAL PROPERTY RIGHTS.

These resources are intended for skilled developers designing with TI products. You are solely responsible for (1) selecting the appropriate TI products for your application, (2) designing, validating and testing your application, and (3) ensuring your application meets applicable standards, and any other safety, security, regulatory or other requirements.

These resources are subject to change without notice. TI grants you permission to use these resources only for development of an application that uses the TI products described in the resource. Other reproduction and display of these resources is prohibited. No license is granted to any other TI intellectual property right or to any third party intellectual property right. TI disclaims responsibility for, and you fully indemnify TI and its representatives against any claims, damages, costs, losses, and liabilities arising out of your use of these resources.

TI's products are provided subject to [TI's Terms of Sale](#), [TI's General Quality Guidelines](#), or other applicable terms available either on [ti.com](#) or provided in conjunction with such TI products. TI's provision of these resources does not expand or otherwise alter TI's applicable warranties or warranty disclaimers for TI products. Unless TI explicitly designates a product as custom or customer-specified, TI products are standard, catalog, general purpose devices.

TI objects to and rejects any additional or different terms you may propose.

Copyright © 2025, Texas Instruments Incorporated

Last updated 10/2025