

## LMZ30602 2-A Power Module With 2.95-V to 6-V Input in QFN Package

### 1 Features

- Complete Integrated Power Solution Allows Small Footprint, Low-Profile Design
- 9 mm × 11 mm × 2.8 mm package
  - Pin Compatible with LMZ30604 and LMZ30606
- Efficiencies Up To 96%
- Wide-Output Voltage Adjust  
0.8 V to 3.6 V, with  $\pm 1\%$  Reference Accuracy
- Adjustable Switching Frequency  
(500 kHz to 2 MHz)
- Synchronizes to an External Clock
- Adjustable Slow-Start
- Output Voltage Sequencing / Tracking
- Power Good Output
- Programmable Undervoltage Lockout (UVLO)
- Output Overcurrent Protection
- Over Temperature Protection
- Operating Temperature Range:  $-40^{\circ}\text{C}$  to  $85^{\circ}\text{C}$
- Enhanced Thermal Performance:  $12^{\circ}\text{C/W}$
- Meets EN55022 Class B Emissions
  - Integrated Shielded Inductor
- Create a Custom Design Using the LMZ30602 With the [WEBENCH® Power Designer](#)

### 2 Applications

- Broadband & Communications Infrastructure
- Automated Test and Medical Equipment
- Compact PCI / PCI Express / PXI Express
- DSP and FPGA Point of Load Applications
- High Density Distributed Power Systems

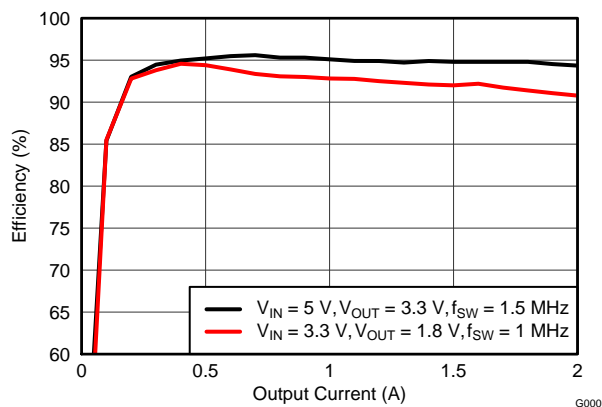

### 3 Description

The LMZ30602 power module is an easy-to-use integrated power solution that combines a 2-A DC/DC converter with power MOSFETs, a shielded inductor, and passives into a low profile, QFN package. This total power solution requires as few as 3 external components and eliminates the loop compensation and magnetics part selection process.

The 9×11×2.8 mm QFN package is easy to solder onto a printed circuit board and allows a compact point-of-load design with greater than 90% efficiency and excellent power dissipation with a thermal impedance of  $12^{\circ}\text{C/W}$  junction to ambient. The device delivers the full 2-A rated output current at  $85^{\circ}\text{C}$  ambient temperature without airflow.

The LMZ30602 offers the flexibility and the feature-set of a discrete point-of-load design and is ideal for powering performance DSPs and FPGAs. Advanced packaging technology afford a robust and reliable power solution compatible with standard QFN mounting and testing techniques.

#### Simplified Application

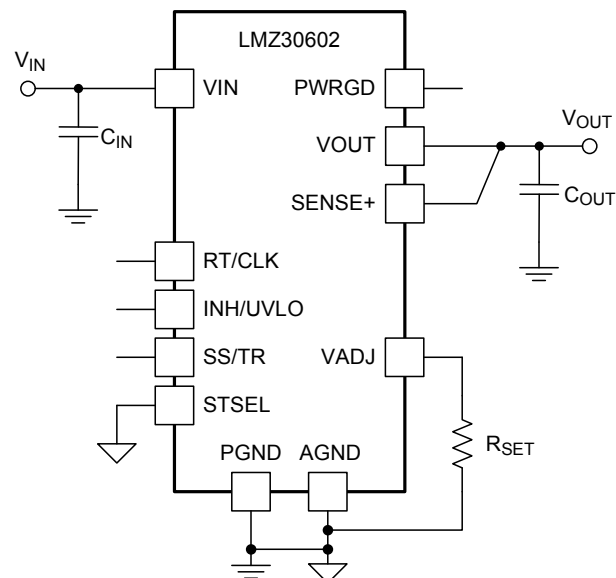

**Table 1. Ordering Information**

For the most current package and ordering information, see the Package Option Addendum at the end of this datasheet, or see the TI website at [www.ti.com](http://www.ti.com).

## 4 Specifications

### 4.1 Absolute Maximum Ratings

 over operating temperature range (unless otherwise noted)<sup>(1)</sup>

		VALUE		UNIT
		MIN	MAX	
Input Voltage	VIN, PWRGD	-0.3	7	V
	INH/UVLO, RT/CLK	-0.3	3.3	V
	SS/TR, STSEL, VADJ	-0.3	3	V
	SENSE+      VADJ rating must also be met	-0.3	VOUT	V
Output Voltage	PH	-0.6	7	V
	PH 10ns Transient	-2	7	V
	VOUT	-0.6	VIN	V
V <sub>DIFF</sub> (GND to exposed thermal pad)		-0.2	0.2	V
Source Current	RT/CLK, INH/UVLO	±100		µA
	PH	Current Limit		A
Sink Current	PH	Current Limit		A
	SS/TR	±100		µA
	PWRGD	10		mA
	Operating Junction Temperature	-40	125 <sup>(2)</sup>	°C
Storage Temperature		-65	150	°C
Peak Reflow Case Temperature <sup>(3)</sup>		250 <sup>(4)</sup>		°C
Maximum Number of Reflows Allowed <sup>(3)</sup>		3 <sup>(4)</sup>		
Mechanical Shock	Mil-STD-883D, Method 2002.3, 1 msec, 1/2 sine, mounted	1500		G
Mechanical Vibration	Mil-STD-883D, Method 2007.2, 20-2000Hz	20		

- (1) Stresses beyond those listed under absolute maximum ratings may cause permanent damage to the device. These are stress ratings only, and functional operation of the device at these or any other conditions beyond those indicated under recommended operating conditions is not implied. Exposure to absolute-maximum-rated conditions for extended periods may affect device reliability.
- (2) See the temperature derating curves in the Typical Characteristics section for thermal information.
- (3) For soldering specifications, refer to the [Soldering Requirements for BQFN Packages](#) application note.
- (4) Devices with a date code prior to week 14 2018 (1814) have a peak reflow case temperature of 240°C with a maximum of one reflow.

### 4.2 Thermal Information

THERMAL METRIC <sup>(1)</sup>		LMZ30602	UNIT
		RKG39	
		39 PINS	
$\theta_{JA}$	Junction-to-ambient thermal resistance <sup>(2)</sup>	12	°C/W
$\psi_{JT}$	Junction-to-top characterization parameter <sup>(3)</sup>	2.2	
$\psi_{JB}$	Junction-to-board characterization parameter <sup>(4)</sup>	9.7	

- (1) For more information about traditional and new thermal metrics, see the IC Package Thermal Metrics application report, [SPRA953](#).
- (2) The junction-to-ambient thermal resistance,  $\theta_{JA}$ , applies to devices soldered directly to a 100 mm x 100 mm double-sided PCB with 1 oz. copper and natural convection cooling. Additional airflow reduces  $\theta_{JA}$ .
- (3) The junction-to-top characterization parameter,  $\psi_{JT}$ , estimates the junction temperature,  $T_J$ , of a device in a real system, using a procedure described in JESD51-2A (sections 6 and 7).  $T_J = \psi_{JT} * P_{dis} + T_T$ ; where  $P_{dis}$  is the power dissipated in the device and  $T_T$  is the temperature of the top of the device.
- (4) The junction-to-board characterization parameter,  $\psi_{JB}$ , estimates the junction temperature,  $T_J$ , of a device in a real system, using a procedure described in JESD51-2A (sections 6 and 7).  $T_J = \psi_{JB} * P_{dis} + T_B$ ; where  $P_{dis}$  is the power dissipated in the device and  $T_B$  is the temperature of the board 1mm from the device.

### 4.3 Electrical Characteristics

Over  $-40^{\circ}\text{C}$  to  $85^{\circ}\text{C}$  free-air temperature,  $V_{\text{IN}} = 3.3\text{ V}$ ,  $V_{\text{OUT}} = 1.8\text{ V}$ ,  $I_{\text{OUT}} = 2\text{ A}$ ,  $C_{\text{IN}1} = 47\text{ }\mu\text{F}$  ceramic,  $C_{\text{IN}2} = 220\text{ }\mu\text{F}$  poly-tantalum,  $C_{\text{OUT}1} = 47\text{ }\mu\text{F}$  ceramic,  $C_{\text{OUT}2} = 100\text{ }\mu\text{F}$  poly-tantalum (unless otherwise noted)

PARAMETER		TEST CONDITIONS	MIN	TYP	MAX	UNIT	
$I_{\text{OUT}}$	Output current	$T_{\text{A}} = 85^{\circ}\text{C}$ , natural convection	0		2	A	
$V_{\text{IN}}$	Input voltage range	Over $I_{\text{OUT}}$ range	2.95 <sup>(1)</sup>		6	V	
$UVLO$	$V_{\text{IN}}$ Undervoltage lockout	$V_{\text{IN}} = \text{increasing}$		3.05	3.135	V	
		$V_{\text{IN}} = \text{decreasing}$	2.5	2.75			
$V_{\text{OUT(ajd)}}$	Output voltage adjust range	Over $I_{\text{OUT}}$ range	0.8		3.6	V	
$V_{\text{OUT}}$	Set-point voltage tolerance	$T_{\text{A}} = 25^{\circ}\text{C}$ , $I_{\text{OUT}} = 0\text{ A}$			$\pm 1.0\%$ <sup>(2)</sup>		
	Temperature variation	$-40^{\circ}\text{C} \leq T_{\text{A}} \leq +85^{\circ}\text{C}$ , $I_{\text{OUT}} = 0\text{ A}$		$\pm 0.3\%$			
	Line regulation	Over $V_{\text{IN}}$ range, $T_{\text{A}} = 25^{\circ}\text{C}$ , $I_{\text{OUT}} = 0\text{ A}$		$\pm 0.1\%$			
	Load regulation	Over $I_{\text{OUT}}$ range, $T_{\text{A}} = 25^{\circ}\text{C}$		$\pm 0.1\%$			
	Total output voltage variation	Includes set-point, line, load, and temperature variation				$\pm 1.5\%$ <sup>(2)</sup>	
$\eta$	Efficiency	$V_{\text{IN}} = 5\text{ V}$ $I_{\text{O}} = 1\text{ A}$	$V_{\text{OUT}} = 3.3\text{ V}$ , $f_{\text{SW}} = 1.5\text{ MHz}$		95%		
			$V_{\text{OUT}} = 2.5\text{ V}$ , $f_{\text{SW}} = 1.5\text{ MHz}$		93%		
			$V_{\text{OUT}} = 1.8\text{ V}$ , $f_{\text{SW}} = 1\text{ MHz}$		92%		
			$V_{\text{OUT}} = 1.5\text{ V}$ , $f_{\text{SW}} = 1\text{ MHz}$		91%		
			$V_{\text{OUT}} = 1.2\text{ V}$ , $f_{\text{SW}} = 750\text{ kHz}$		90%		
			$V_{\text{OUT}} = 1.0\text{ V}$ , $f_{\text{SW}} = 650\text{ kHz}$		88%		
		$V_{\text{IN}} = 3.3\text{ V}$ $I_{\text{O}} = 1\text{ A}$	$V_{\text{OUT}} = 0.8\text{ V}$ , $f_{\text{SW}} = 650\text{ kHz}$		87%		
			$V_{\text{OUT}} = 1.8\text{ V}$ , $f_{\text{SW}} = 1\text{ MHz}$		93%		
			$V_{\text{OUT}} = 1.5\text{ V}$ , $f_{\text{SW}} = 1\text{ MHz}$		92%		
			$V_{\text{OUT}} = 1.2\text{ V}$ , $f_{\text{SW}} = 750\text{ kHz}$		91%		
			$V_{\text{OUT}} = 1.0\text{ V}$ , $f_{\text{SW}} = 650\text{ kHz}$		89%		
			$V_{\text{OUT}} = 0.8\text{ V}$ , $f_{\text{SW}} = 650\text{ kHz}$		87%		
	Output voltage ripple	20 MHz bandwidth		9		mV <sub>PP</sub>	
$I_{\text{LIM}}$	Overcurrent threshold			3.5		A	
	Transient response	1.0 A/ $\mu\text{s}$ load step from 0.5A to 1.5A	Recovery time		80	$\mu\text{s}$	
			$V_{\text{OUT}}$ over/undershoot		45	mV	
$V_{\text{INH-H}}$	Inhibit Control	Inhibit High Voltage		1.25	Open <sup>(3)</sup>	V	
$V_{\text{INH-L}}$		Inhibit Low Voltage	-0.3	1.0			
$I_{\text{I(stby)}}$	Input standby current	INH pin to AGND		70	100	$\mu\text{A}$	
Power Good	PWRGD Thresholds	$V_{\text{OUT}}$ rising	Good		93%		
			Fault		107%		
		$V_{\text{OUT}}$ falling	Fault		91%		
			Good		105%		
	PWRGD Low Voltage	$I(\text{PWRGD}) = 0.33\text{ mA}$			0.3	V	
$f_{\text{SW}}$	Switching frequency	Over $V_{\text{IN}}$ and $I_{\text{OUT}}$ ranges, RT/CLK pin OPEN	400	500	600	kHz	
$f_{\text{CLK}}$	Synchronization frequency		500		2000	kHz	
$V_{\text{CLK-H}}$	CLK High-Level Threshold	CLK Control		2.2	3.3	V	
$V_{\text{CLK-L}}$	CLK Low-Level Threshold			-0.3	0.4	V	
CLK_PW	CLK Pulse Width			75 <sup>(4)</sup>		ns	
	Thermal Shutdown	Thermal shutdown		175		$^{\circ}\text{C}$	
		Thermal shutdown hysteresis		15		$^{\circ}\text{C}$	

- (1) The minimum  $V_{\text{IN}}$  depends on  $V_{\text{OUT}}$  and the switching frequency. Please refer to [Table 9](#) for operating limits.
- (2) The stated limit of the set-point voltage tolerance includes the tolerance of both the internal voltage reference and the internal adjustment resistor. The overall output voltage tolerance will be affected by the tolerance of the external  $R_{\text{SET}}$  resistor.
- (3) This control pin has an internal pullup. Do not place an external pull-up resistor on this pin. If this pin is left open circuit, the device operates when input power is applied. A small low-leakage MOSFET is recommended for control. See the application section for further guidance.
- (4) The maximum synchronization clock pulse width is dependant on  $V_{\text{IN}}$ ,  $V_{\text{OUT}}$ , and the synchronization frequency. See the [Synchronization \(CLK\)](#) section for more information.

## Electrical Characteristics (continued)

Over -40°C to 85°C free-air temperature,  $V_{IN} = 3.3\text{ V}$ ,  $V_{OUT} = 1.8\text{ V}$ ,  $I_{OUT} = 2\text{ A}$ ,  
 $C_{IN1} = 47\text{ }\mu\text{F}$  ceramic,  $C_{IN2} = 220\text{ }\mu\text{F}$  poly-tantalum,  $C_{OUT1} = 47\text{ }\mu\text{F}$  ceramic,  $C_{OUT2} = 100\text{ }\mu\text{F}$  poly-tantalum (unless otherwise noted)

PARAMETER		TEST CONDITIONS	MIN	TYP	MAX	UNIT
$C_{IN}$	External input capacitance	Ceramic	47 <sup>(5)</sup>			$\mu\text{F}$
		Non-ceramic		220 <sup>(5)</sup>		
$C_{OUT}$	External output capacitance	Ceramic	47 <sup>(6)</sup>	150	650 <sup>(7)</sup>	$\mu\text{F}$
		Non-ceramic		100 <sup>(6)</sup>	1000 <sup>(7)</sup>	
		Equivalent series resistance (ESR)				25

- (5) A minimum of 47 $\mu\text{F}$  of ceramic capacitance is required across the input for proper operation. Locate the capacitor close to the device. An additional 220 $\mu\text{F}$  of bulk capacitance is recommended. See [Table 7](#) for more details.
- (6) The amount of required output capacitance varies depending on the output voltage (see [Table 5](#)). The amount of required capacitance must include at least 47 $\mu\text{F}$  of ceramic capacitance. Locate the capacitance close to the device. Adding additional capacitance close to the load improves the response of the regulator to load transients. See [Table 5](#) and [Table 7](#) for more details.
- (7) When using both ceramic and non-ceramic output capacitance, the combined maximum must not exceed 1200 $\mu\text{F}$ .

## 4.4 Package Specifications

LMZ30602		UNIT
Weight		0.85 grams
Flammability	Meets UL 94 V-O	
MTBF Calculated reliability	Per Bellcore TR-332, 50% stress, $T_A = 40^\circ\text{C}$ , ground benign	38.5 Mhrs

## 5 Device Information

FUNCTIONAL BLOCK DIAGRAM

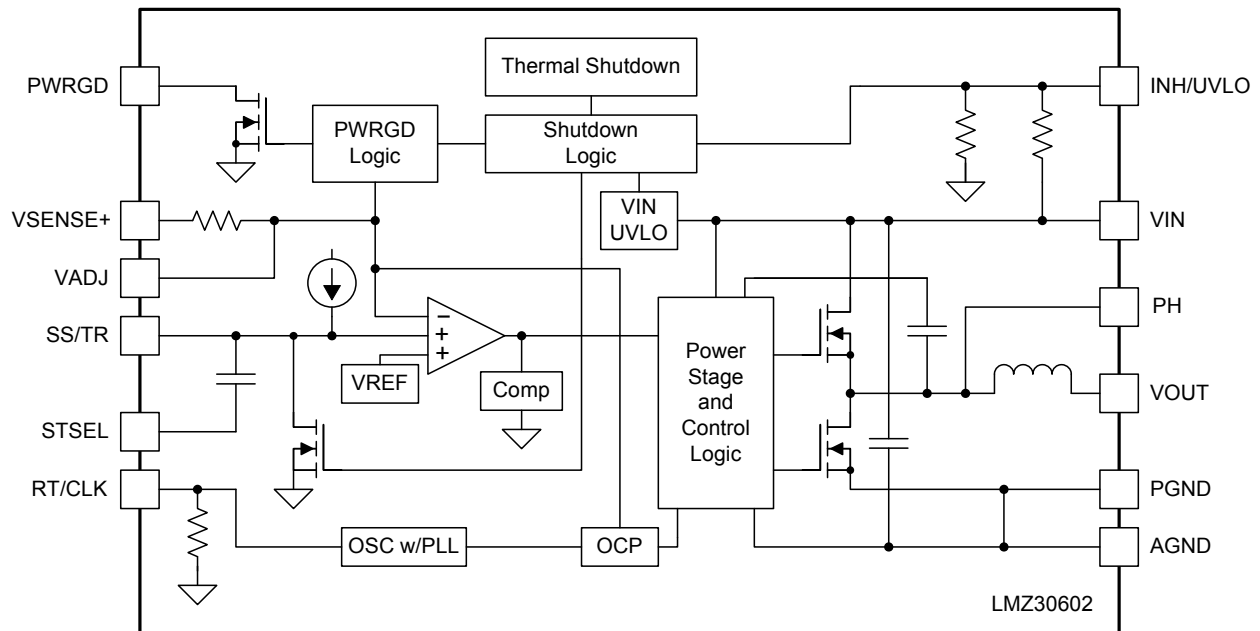

**Table 2. PIN DESCRIPTIONS**

TERMINAL		DESCRIPTION
NAME	NO.	
AGND	1	Zero VDC reference for the analog control circuitry. These pins should be connected directly to the PCB analog ground plane. Not all pins are connected together internally. All pins must be connected together externally with a copper plane or pour directly under the module. Connect the AGND copper area to the PGND copper area at a single point; directly at the pin 37 PowerPAD using multiple vias. See the recommended layout in <a href="#">Figure 36</a> .
	5	
	29	
	33	
	34	
PowerPAD (PGND)	37	This pad provides both an electrical and thermal connection to the PCB. This pad should be connected directly to the PCB power ground plane using multiple vias for good electrical and thermal performance. The same vias should also be used to connect to the PCB analog ground plane. See the recommended layout in <a href="#">Figure 36</a> .
DNC	2	Do Not Connect. Do not connect these pins to AGND, to another DNC pin, or to any other voltage. These pins are connected to internal circuitry. Each pin must be soldered to an isolated pad.
	3	
	15	
	16	
	26	
INH/UVLO	28	Inhibit and UVLO adjust pin. Use an open drain or open collector output logic to control the INH function. A resistor between this pin and AGND adjusts the UVLO voltage.
PH	17	Phase switch node. These pins should be connected by a small copper island under the device for thermal relief. Do not connect any external component to this pin or tie it to a pin of another function.
	18	
	19	
	20	
	21	
	22	
	23	
	24	
	25	
39		
PWRGD	27	Power good fault pin. Asserts low if the output voltage is out of tolerance. A pull-up resistor is required.
RT/CLK	4	This pin automatically selects between RT mode and CLK mode. An external timing resistor adjusts the switching frequency of the device. In CLK mode, the device synchronizes to an external clock.
SENSE+	36	Remote sense connection. Connect this pin to VOUT at the load for improved regulation. This pin must be connected to VOUT at the load, or at the module pins.
SS/TR	6	Slow-start and tracking pin. Connecting an external capacitor to this pin adjusts the output voltage rise time. A voltage applied to this pin allows for tracking and sequencing control.
STSEL	7	Slow-start or track feature select. Connect this pin to AGND to enable the internal SS capacitor with a SS interval of approximately 1.1 ms. Leave this pin open to enable the TR feature.
VADJ	35	Connecting a resistor between this pin and AGND sets the output voltage above the 0.8V default voltage.
VIN	30	The positive input voltage power pins, which are referenced to PGND. Connect external input capacitance between these pins and the PGND plane, close to the device.
	31	
	32	
VOUT	8	Output voltage. Connect output capacitors between these pins and the PGND plane, close to the device.
	9	
	10	
	11	
	12	
	13	
	14	
38		

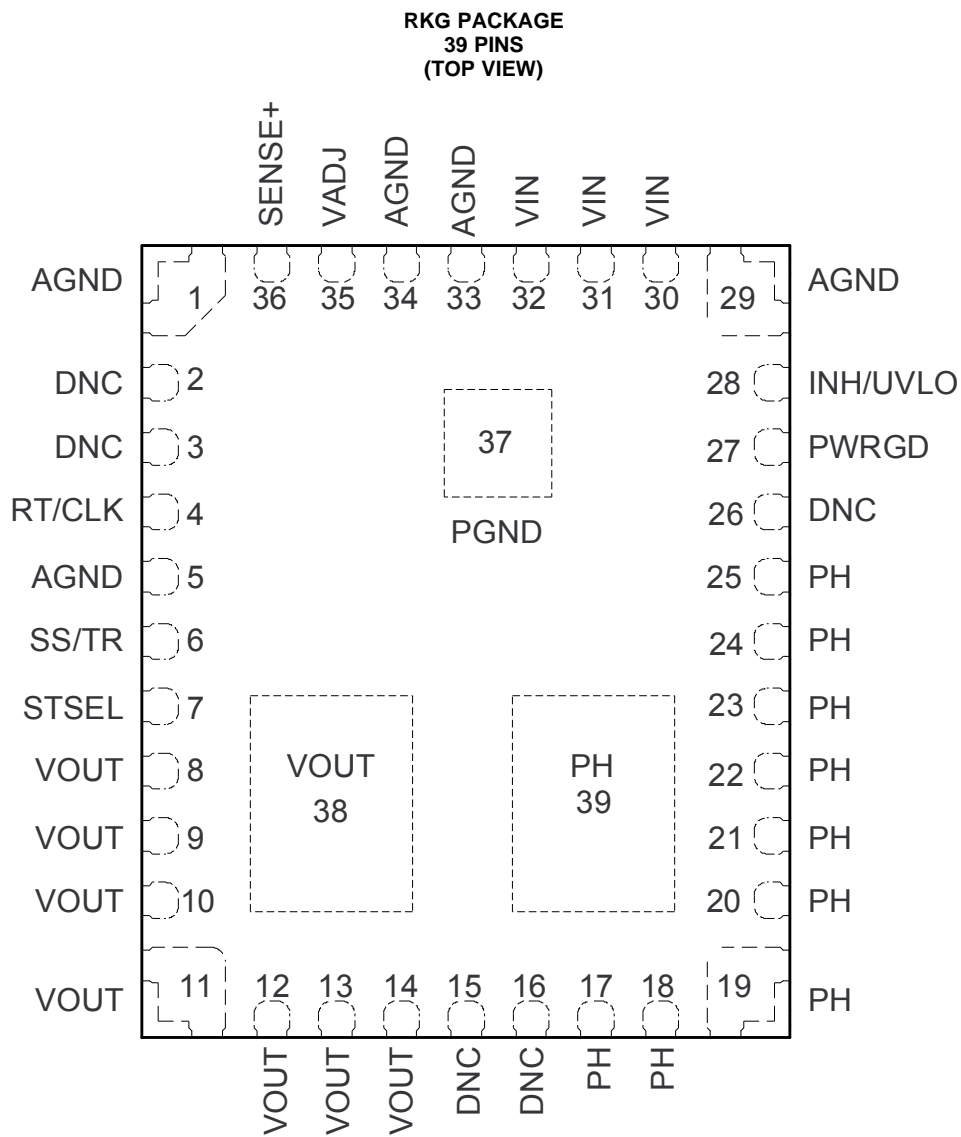

## 6 Typical Characteristics (VIN = 5 V)

The electrical characteristic data has been developed from actual products tested at 25°C. This data is considered typical for the converter. Applies to [Figure 1](#), [Figure 2](#), and [Figure 3](#). The temperature derating curves represent the conditions at which internal components are at or below the manufacturer's maximum operating temperatures. Derating limits apply to devices soldered directly to a 100 mm × 100 mm double-sided PCB with 1 oz. copper. Applies to [Figure 4](#).

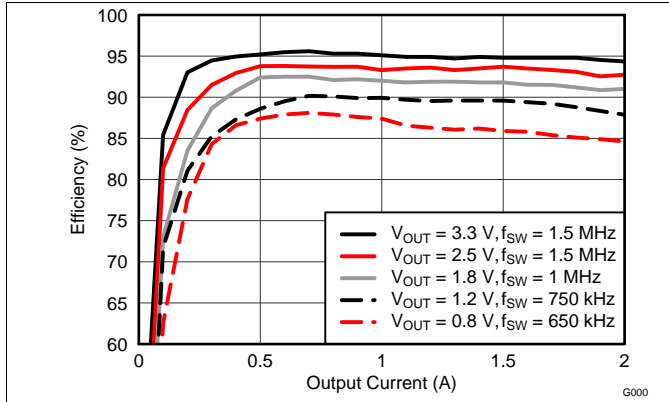

Figure 1. Efficiency vs. Output Current

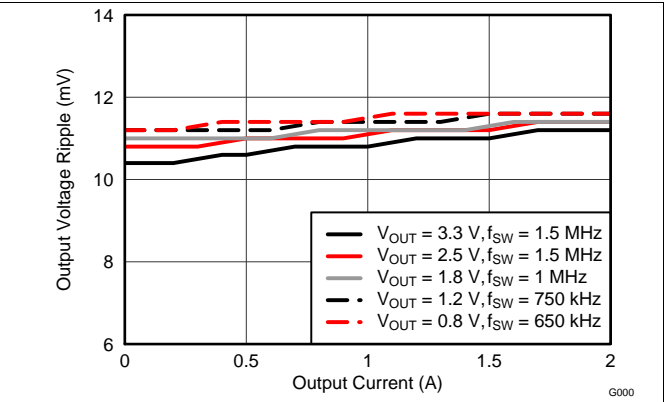

Figure 2. Voltage Ripple vs. Output Current

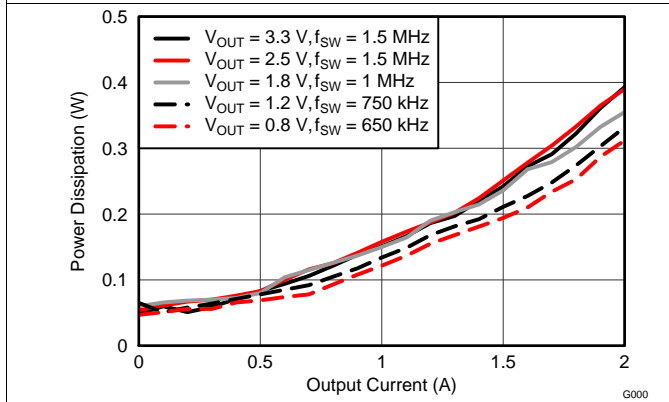

Figure 3. Power Dissipation vs. Output Current

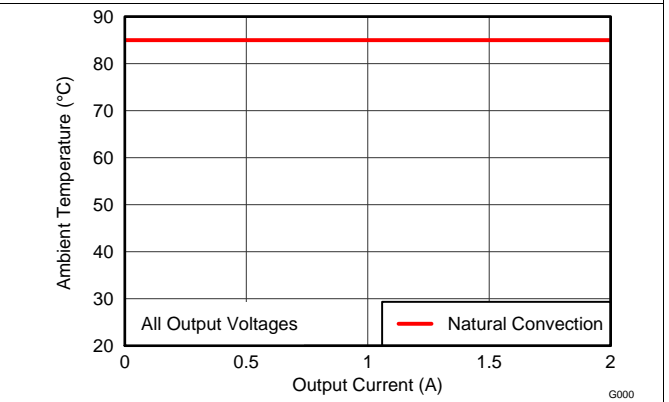

Figure 4. Safe Operating Area

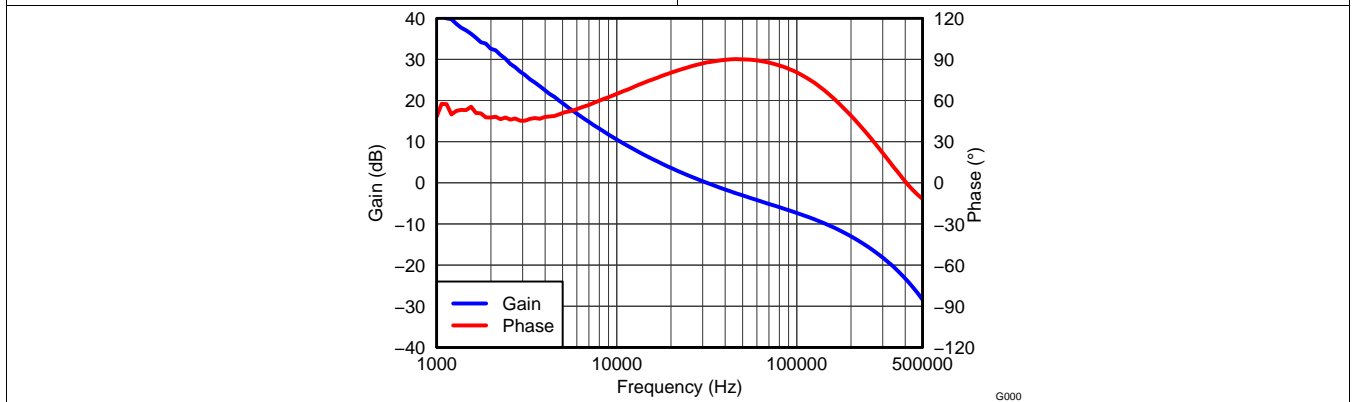

Figure 5.  $V_{OUT} = 1.8\text{ V}$ ,  $I_{OUT} = 2\text{ A}$ ,  $C_{OUT1} = 47\text{ }\mu\text{F}$  ceramic,  $C_{OUT2} = 100\text{ }\mu\text{F}$  POSCAP,  $f_{SW} = 1\text{ MHz}$



## 7 Typical Characteristics (VIN = 3.3 V)

The electrical characteristic data has been developed from actual products tested at 25°C. This data is considered typical for the converter. Applies to Figure 6, Figure 7, and Figure 8. The temperature derating curves represent the conditions at which internal components are at or below the manufacturer's maximum operating temperatures. Derating limits apply to devices soldered directly to a 100 mm × 100 mm double-sided PCB with 1 oz. copper. Applies to Figure 9.

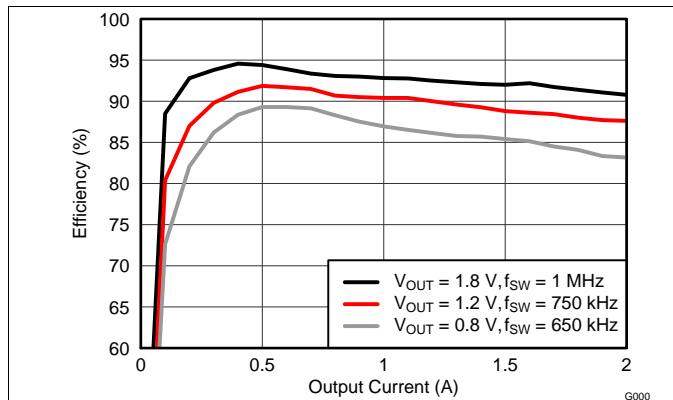

Figure 6. Efficiency vs. Output Current

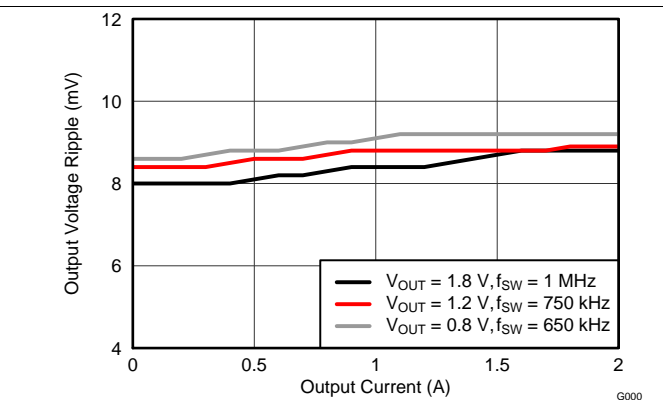

Figure 7. Voltage Ripple vs. Output Current

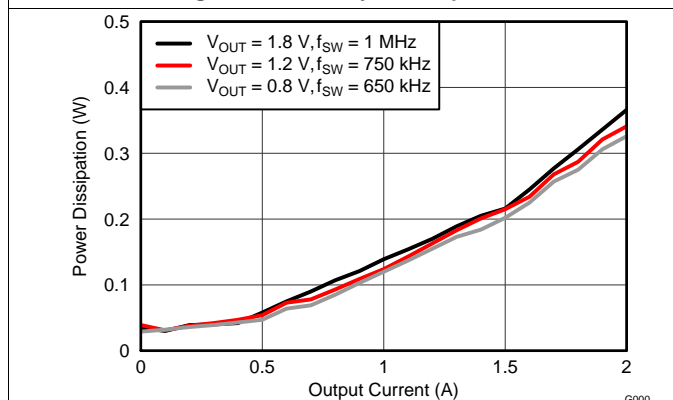

Figure 8. Power Dissipation vs. Output Current

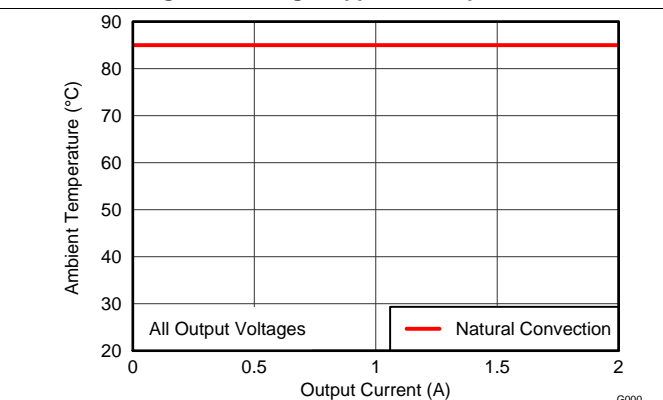

Figure 9. Safe Operating Area

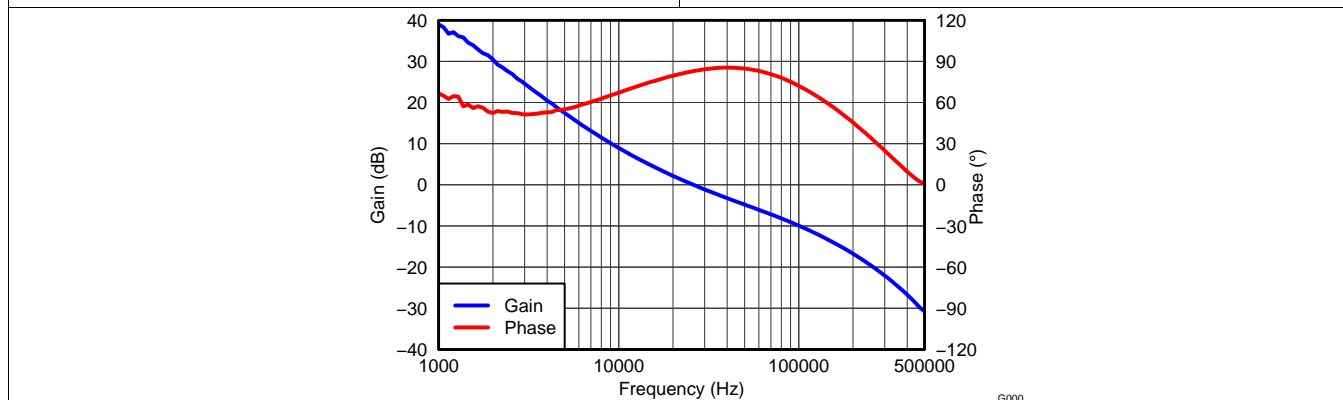

Figure 10.  $V_{OUT} = 1.8\text{ V}$ ,  $I_{OUT} = 2\text{ A}$ ,  $C_{OUT1} = 47\text{ }\mu\text{F}$  ceramic,  $C_{OUT2} = 100\text{ }\mu\text{F}$  POSCAP,  $f_{SW} = 1\text{ MHz}$

## 8 Application Information

### 8.1 Adjusting the Output Voltage

The VADJ control sets the output voltage of the LMZ30602. The output voltage adjustment range is from 0.8V to 3.6V. The adjustment method requires the addition of  $R_{SET}$ , which sets the output voltage, the connection of SENSE+ to VOUT, and in some cases  $R_{RT}$  which sets the switching frequency. The  $R_{SET}$  resistor must be connected directly between the VADJ (pin 35) and AGND (pin 33 & 34). The SENSE+ pin (pin 36) must be connected to VOUT either at the load for improved regulation or at VOUT of the module. The  $R_{RT}$  resistor must be connected directly between the RT/CLK (pin 4) and AGND (pins 33 & 34).

[Table 3](#) gives the standard external  $R_{SET}$  resistor for a number of common bus voltages, along with the recommended  $R_{RT}$  resistor for that output voltage.

**Table 3. Standard  $R_{SET}$  Resistor Values for Common Output Voltages**

RESISTORS	OUTPUT VOLTAGE $V_{OUT}$ (V)					
	0.8	1.2	1.5	1.8	2.5	3.3
$R_{SET}$ (k $\Omega$ )	open	2.87	1.65	1.15	0.673	0.459
$R_{RT}$ (k $\Omega$ )	1200	715	348	348	174	174

For other output voltages, the value of the required resistor can either be calculated using the following formula, or simply selected from the range of values given in [Table 4](#).

$$R_{SET} = \frac{1.43}{\left(\left(\frac{V_{OUT}}{0.803}\right) - 1\right)} \text{ (k}\Omega\text{)} \quad (1)$$

**Table 4. Standard  $R_{SET}$  Resistor Values**

$V_{OUT}$ (V)	$R_{SET}$ (k $\Omega$ )	$R_{RT}$ (k $\Omega$ )	$f_{sw}$ (kHz)	$V_{OUT}$ (V)	$R_{SET}$ (k $\Omega$ )	$R_{RT}$ (k $\Omega$ )	$f_{sw}$ (kHz)
0.8	open	1200	650	2.3	0.768	174	1500
0.9	11.8	1200	650	2.4	0.715	174	1500
1.0	5.83	1200	650	2.5	0.673	174	1500
1.1	3.83	1200	650	2.6	0.634	174	1500
1.2	2.87	715	750	2.7	0.604	174	1500
1.3	2.32	715	750	2.8	0.576	174	1500
1.4	1.91	715	750	2.9	0.549	174	1500
1.5	1.65	348	1000	3.0	0.523	174	1500
1.6	1.43	348	1000	3.1	0.499	174	1500
1.7	1.27	348	1000	3.2	0.475	174	1500
1.8	1.15	348	1000	3.3	0.459	174	1500
1.9	1.05	348	1000	3.4	0.442	174	1500
2.0	0.953	174	1500	3.5	0.422	174	1500
2.1	0.845	174	1500	3.6	0.412	174	1500
2.2	0.825	174	1500				

## 8.2 Capacitor Recommendations for the LMZ30602 Power Supply

### 8.2.1 Capacitor Technologies

#### 8.2.1.1 Electrolytic, Polymer-Electrolytic Capacitors

When using electrolytic capacitors, high-quality, computer-grade electrolytic capacitors are recommended. Polymer-electrolytic type capacitors are recommended for applications where the ambient operating temperature is less than 0°C. The Sanyo OS-CON capacitor series is suggested due to the lower ESR, higher rated surge, power dissipation, ripple current capability, and small package size. Aluminum electrolytic capacitors provide adequate decoupling over the frequency range of 2 kHz to 150 kHz, and are suitable when ambient temperatures are above 0°C.

#### 8.2.1.2 Ceramic Capacitors

The performance of aluminum electrolytic capacitors is less effective than ceramic capacitors above 150 kHz. Multilayer ceramic capacitors have a low ESR and a resonant frequency higher than the bandwidth of the regulator. They can be used to reduce the reflected ripple current at the input as well as improve the transient response of the output.

#### 8.2.1.3 Tantalum, Polymer-Tantalum Capacitors

Polymer-tantalum type capacitors are recommended for applications where the ambient operating temperature is less than 0°C. The Sanyo POSCAP series and Kemet T530 capacitor series are recommended rather than many other tantalum types due to their lower ESR, higher rated surge, power dissipation, ripple current capability, and small package size. Tantalum capacitors that have no stated ESR or surge current rating are not recommended for power applications.

### 8.2.2 Input Capacitor

The LMZ30602 requires a minimum input capacitance of 47  $\mu\text{F}$  of ceramic capacitance. An additional 220  $\mu\text{F}$  polymer-tantalum capacitor is recommended for applications with transient load requirements. The combined ripple current rating of the input capacitors must be at least 1000 mArms. [Table 7](#) includes a preferred list of capacitors by vendor. For applications where the ambient operating temperature is less than 0°C, an additional 1  $\mu\text{F}$ , X5R or X7R ceramic capacitor placed between VIN and AGND is recommended.

### 8.2.3 Output Capacitor

The required output capacitance is determined by the output voltage of the LMZ30602. See [Table 5](#) for the amount of required capacitance. The required output capacitance must include at least one 47  $\mu\text{F}$  ceramic capacitor. For applications where the ambient operating temperature is less than 0°C, an additional 100  $\mu\text{F}$  polymer-tantalum capacitor is recommended. When adding additional non-ceramic bulk capacitors, low-ESR devices like the ones recommended in [Table 7](#) are required. The required capacitance above the minimum is determined by actual transient deviation requirements. See [Table 6](#) for typical transient response values for several output voltage, input voltage and capacitance combinations. [Table 7](#) includes a preferred list of capacitors by vendor.

**Table 5. Required Output Capacitance**

V <sub>OUT</sub> RANGE (V)		MINIMUM REQUIRED C <sub>OUT</sub> ( $\mu\text{F}$ )
MIN	MAX	
0.8	< 1.8	147 <sup>(1)</sup>
1.8	< 3.3	100 <sup>(2)</sup>
3.3	3.6	47 <sup>(2)</sup>

- (1) Minimum required must include at least 1 x 47  $\mu\text{F}$  ceramic capacitor plus 1 x 100  $\mu\text{F}$  polymer-tantalum capacitor.
- (2) Minimum required must include at least 47  $\mu\text{F}$  of ceramic capacitance.

**Table 6. Output Voltage Transient Response**

$C_{IN1} = 1 \times 47 \mu\text{F CERAMIC}, C_{IN2} = 220 \mu\text{F POLYMER-TANTALUM, LOAD STEP} = 1 \text{ A}, 1 \text{ A}/\mu\text{s}$						
$V_{OUT}$ (V)	$V_{IN}$ (V)	$C_{OUT1}$ Ceramic	$C_{OUT2}$ BULK	VOLTAGE DEVIATION (mV)	PEAK-PEAK (mV)	RECOVERY TIME ( $\mu\text{s}$ )
0.8	3.3	47 $\mu\text{F}$	100 $\mu\text{F}$	30	55	70
		47 $\mu\text{F}$	330 $\mu\text{F}$	20	35	70
	5	47 $\mu\text{F}$	100 $\mu\text{F}$	30	50	65
		47 $\mu\text{F}$	330 $\mu\text{F}$	20	35	65
1.2	3.3	47 $\mu\text{F}$	100 $\mu\text{F}$	35	65	65
		47 $\mu\text{F}$	330 $\mu\text{F}$	25	50	80
	5	47 $\mu\text{F}$	100 $\mu\text{F}$	35	70	65
		47 $\mu\text{F}$	330 $\mu\text{F}$	25	45	75
1.8	3.3	47 $\mu\text{F}$	100 $\mu\text{F}$	45	80	70
		47 $\mu\text{F}$	330 $\mu\text{F}$	35	65	90
	5	47 $\mu\text{F}$	100 $\mu\text{F}$	40	65	70
		47 $\mu\text{F}$	330 $\mu\text{F}$	35	65	90
2.5	5	47 $\mu\text{F}$	100 $\mu\text{F}$	60	100	70
		2x 47 $\mu\text{F}$	-	75	140	75
3.3	5	47 $\mu\text{F}$	100 $\mu\text{F}$	70	130	80
		47 $\mu\text{F}$	-	90	180	90

**Table 7. Recommended Input/Output Capacitors<sup>(1)</sup>**

VENDOR	SERIES	PART NUMBER	CAPACITOR CHARACTERISTICS		
			WORKING VOLTAGE (V)	CAPACITANCE ( $\mu\text{F}$ )	ESR <sup>(2)</sup> (m $\Omega$ )
Murata	X5R	GRM32ER61C476K	16	47	2
TDK	X5R	C3225X5R0J107M	6.3	100	2
Murata	X5R	GRM32ER60J107M	6.3	100	2
TDK	X5R	C3225X5R0J476K	6.3	47	2
Murata	X5R	GRM32ER60J476M	6.3	47	2
Sanyo	POSCAP	10TPE220ML	10	220	25
Kemet	T520	T520V107M010ASE025	10	100	25
Sanyo	POSCAP	6TPE100MPB	6.3	100	25
Sanyo	POSCAP	2R5TPE220M7	2.5	220	7
Kemet	T530	T530D227M006ATE006	6.3	220	6
Kemet	T530	T530D337M006ATE010	6.3	330	10
Sanyo	POSCAP	2TPF330M6	2.0	330	6
Sanyo	POSCAP	6TPE330MFL	6.3	330	15

**(1) Capacitor Supplier Verification**

Please verify availability of capacitors identified in this table.

**RoHS, Lead-free and Material Details**

Please consult capacitor suppliers regarding material composition, RoHS status, lead-free status, and manufacturing process requirements.

**(2) Maximum ESR @ 100kHz, 25°C.**

### 8.3 Transient Response

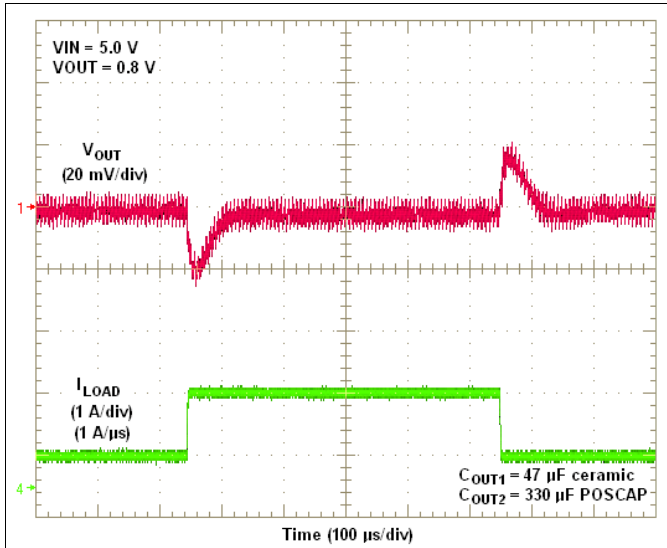

Figure 11. VIN = 5V, VOUT = 0.8V, 1A Load Step

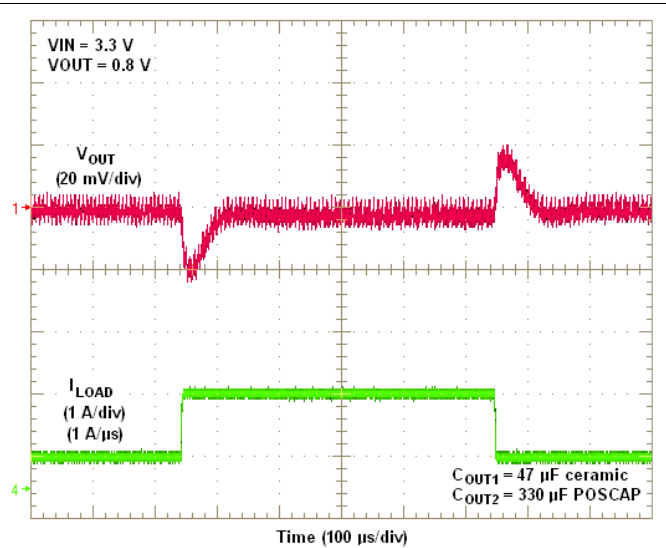

Figure 12. VIN = 3.3V, VOUT = 0.8V, 1A Load Step

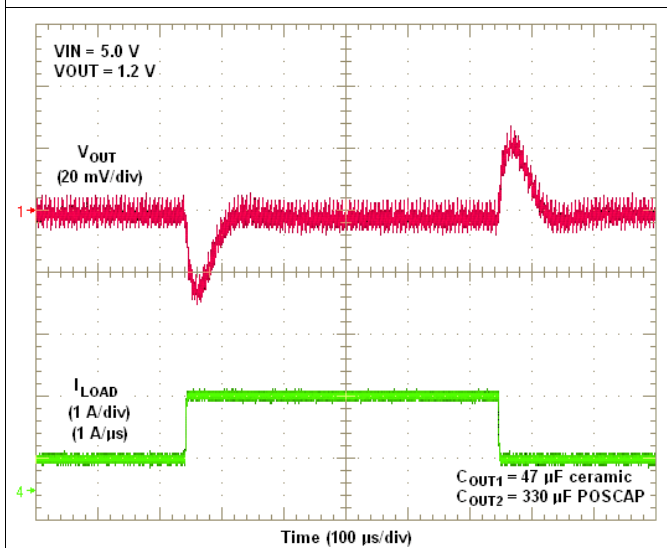

Figure 13. VIN = 5V, VOUT = 1.2V, 1A Load Step

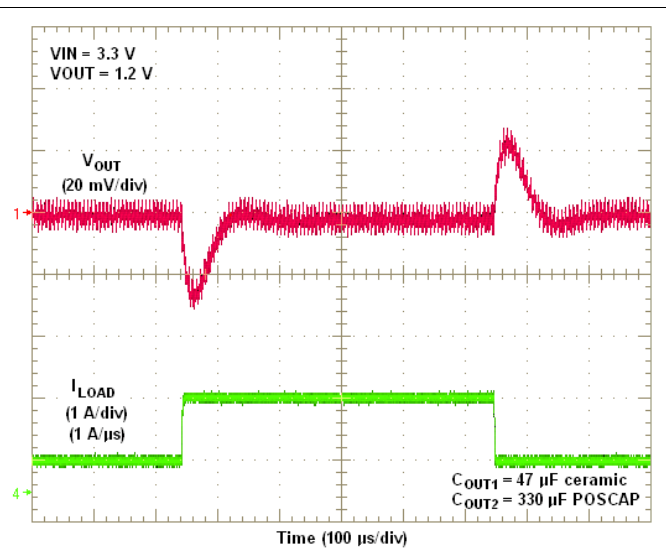
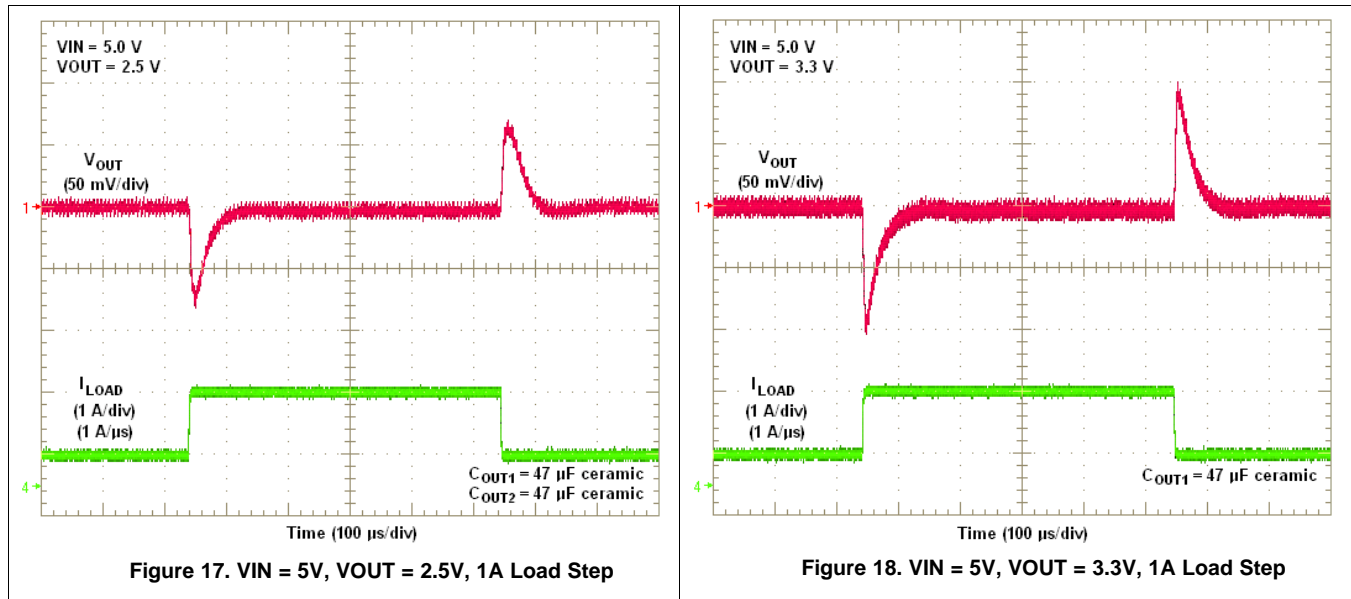
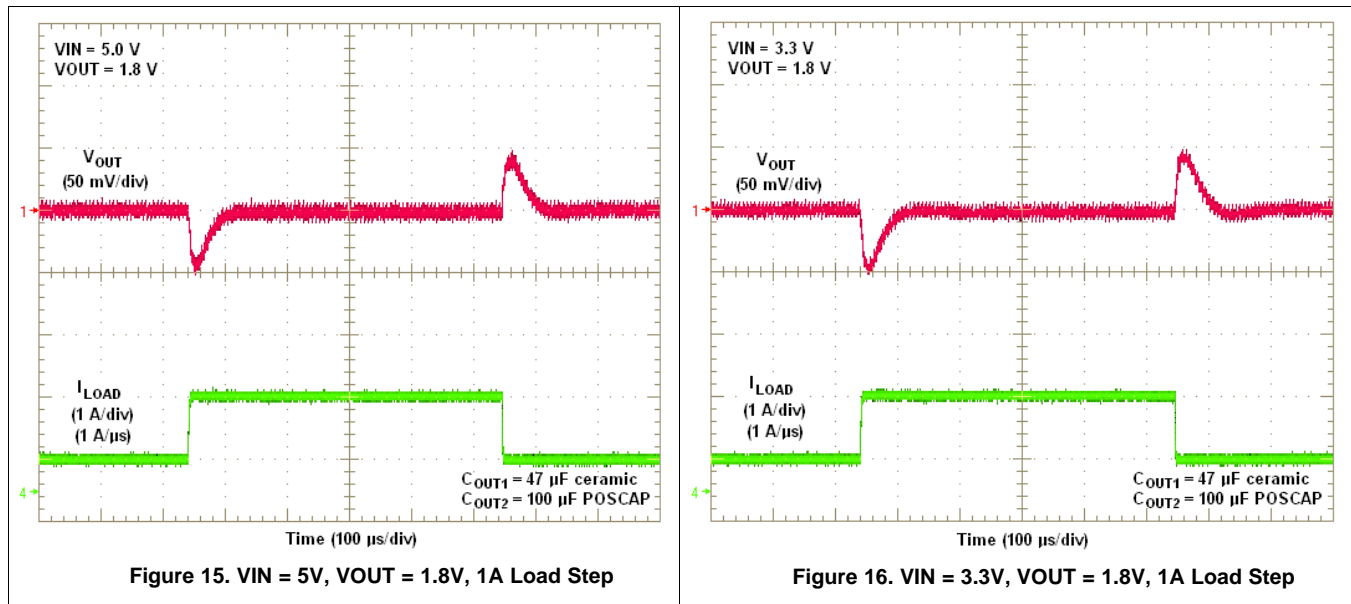
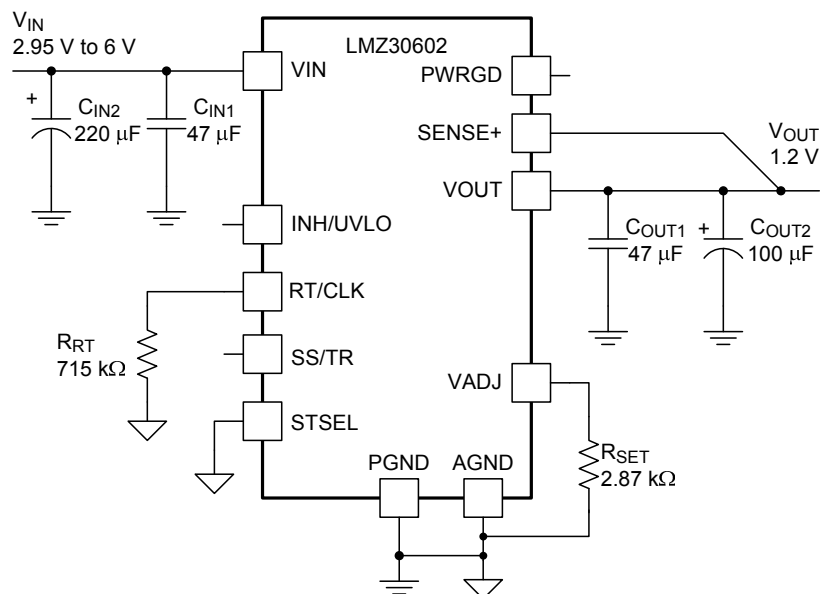

Figure 14. VIN = 3.3V, VOUT = 1.2V, 1A Load Step

Transient Response (continued)



## 8.4 Application Schematics



**Figure 19. Typical Schematic**  
VIN = 2.95 V to 6.0 V, VOUT = 1.2 V

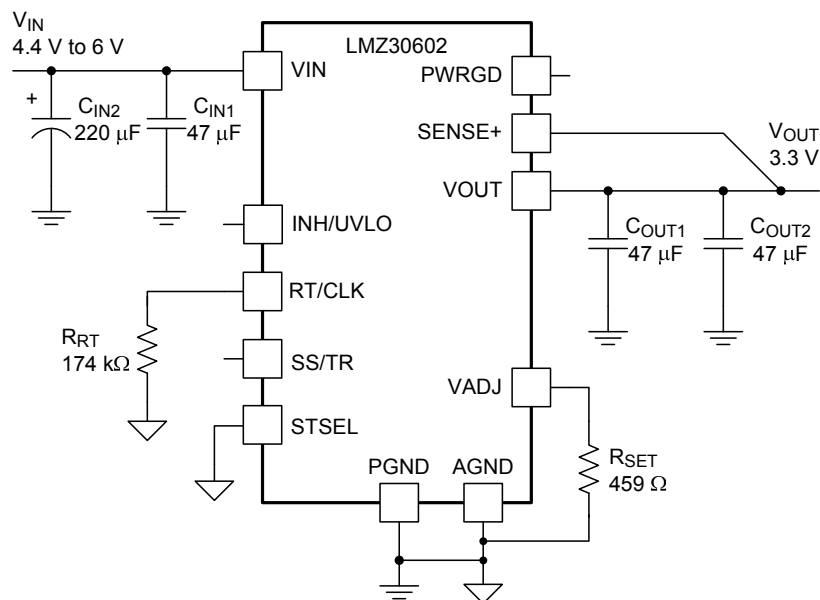

**Figure 20. Typical Schematic**  
VIN = 4.4 V to 6.0 V, VOUT = 3.3 V

## 8.5 Custom Design With WEBENCH® Tools

[Click here](#) to create a custom design using the LMZ30602 device with the WEBENCH® Power Designer.

1. Start by entering the input voltage ( $V_{IN}$ ), output voltage ( $V_{OUT}$ ), and output current ( $I_{OUT}$ ) requirements.
2. Optimize the design for key parameters such as efficiency, footprint, and cost using the optimizer dial.
3. Compare the generated design with other possible solutions from Texas Instruments.

The WEBENCH Power Designer provides a customized schematic along with a list of materials with real-time pricing and component availability.

In most cases, these actions are available:

- Run electrical simulations to see important waveforms and circuit performance
- Run thermal simulations to understand board thermal performance
- Export customized schematic and layout into popular CAD formats
- Print PDF reports for the design, and share the design with colleagues

Get more information about WEBENCH tools at [www.ti.com/WEBENCH](http://www.ti.com/WEBENCH).

## 8.6 Power Good (PWRGD)

The PWRGD pin is an open drain output. Once the voltage on the SENSE+ pin is between 93% and 105% of the set voltage, the PWRGD pin pull-down is released and the pin floats. The recommended pull-up resistor value is between 10 k $\Omega$  and 100 k $\Omega$  to a voltage source that is 6 V or less. The PWRGD pin is in a defined state once  $V_{IN}$  is greater than 1.2 V, but with reduced current sinking capability. The PWRGD pin achieves full current sinking capability once the  $V_{IN}$  pin is above 2.95V. [Figure 21](#) shows the PWRGD waveform during power-up. The PWRGD pin is pulled low when the voltage on SENSE+ is lower than 91% or greater than 107% of the nominal set voltage. Also, the PWRGD pin is pulled low if the input UVLO or thermal shutdown is asserted, or if the INH pin is pulled low.



## 8.7 Power-Up Characteristics

When configured as shown in the front page schematic, the LMZ30602 produces a regulated output voltage following the application of a valid input voltage. During the power-up, internal soft-start circuitry slows the rate that the output voltage rises, thereby limiting the amount of in-rush current that can be drawn from the input source. The soft-start circuitry introduces a short time delay from the point that a valid input voltage is recognized. Figure 21 shows the start-up waveforms for a LMZ30602, operating from a 5-V input and with the output voltage adjusted to 1.8 V. The waveform is measured with a 2-A constant current load.

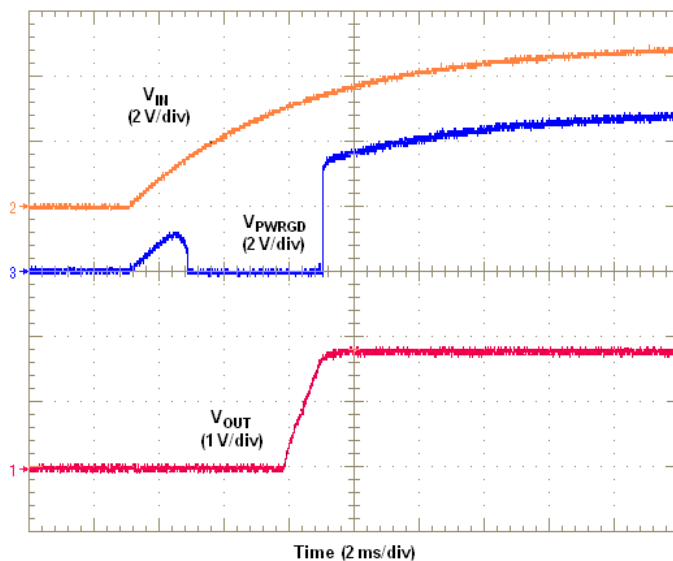

Figure 21. Start-Up Waveforms

## 8.8 Remote Sense

The SENSE+ pin must be connected to  $V_{OUT}$  at the load, or at the device pins.

Connecting the SENSE+ pin to  $V_{OUT}$  at the load improves the load regulation performance of the device by allowing it to compensate for any I-R voltage drop between its output pins and the load. An I-R drop is caused by the high output current flowing through the small amount of pin and trace resistance. This should be limited to a maximum of 300 mV.

### NOTE

The remote sense feature is not designed to compensate for the forward drop of nonlinear or frequency dependent components that may be placed in series with the converter output. Examples include OR-ing diodes, filter inductors, ferrite beads, and fuses. When these components are enclosed by the SENSE+ connection, they are effectively placed inside the regulation control loop, which can adversely affect the stability of the regulator.

## 8.9 Output On/Off Inhibit (INH)

The INH pin provides electrical on/off control of the device. Once the INH pin voltage exceeds the threshold voltage, the device starts operation. If the INH pin voltage is pulled below the threshold voltage, the regulator stops switching and enters low quiescent current state.

The INH pin has an internal pull-up current source, allowing the user to float the INH pin for enabling the device. If an application requires controlling the INH pin, use an open drain/collector device, or a suitable logic gate to interface with the pin. Do not place an external pull-up resistor on this pin. [Figure 22](#) shows the typical application of the inhibit function.

Turning Q1 on applies a low voltage to the inhibit control (INH) pin and disables the output of the supply, as shown in [Figure 23](#). If Q1 is turned off, the supply executes a soft-start power-up sequence, as shown in [Figure 24](#). The waveforms were measured with a 2-A constant current load.

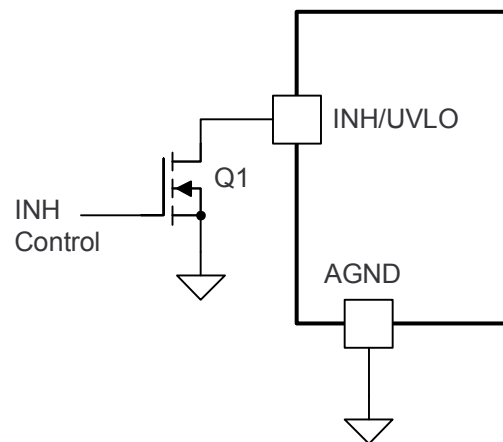

**Figure 22. Typical Inhibit Control**

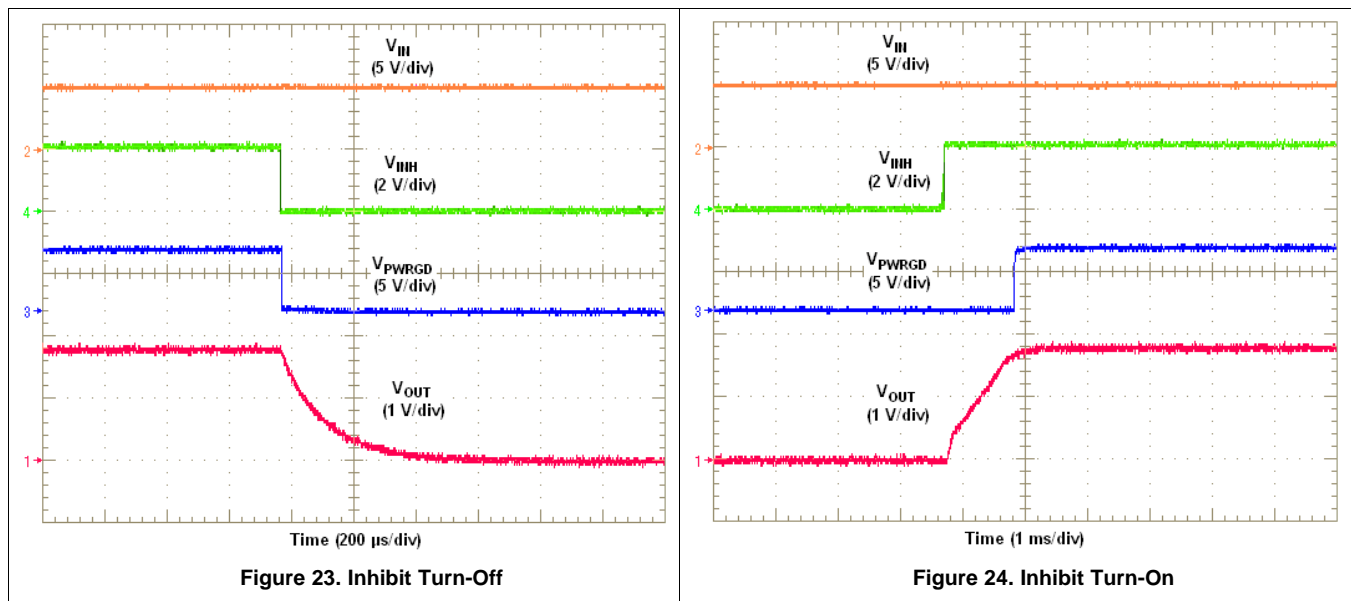

### 8.10 Slow Start (SS/TR)

Connecting the STSEL pin to AGND and leaving SS/TR pin open enables the internal SS capacitor with a slow start interval of approximately 1.1 ms. Adding additional capacitance between the SS pin and AGND increases the slow start time. Table 8 shows an additional SS capacitor connected to the SS/TR pin and the STSEL pin connected to AGND. See Table 8 below for SS capacitor values and timing interval.

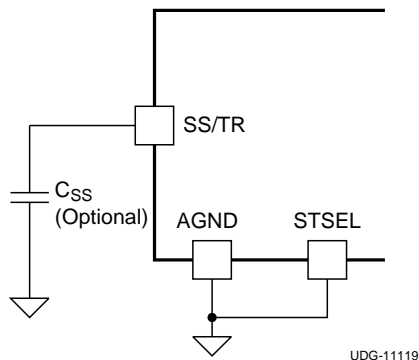

Figure 25. Slow-Start Capacitor (C<sub>SS</sub>) and STSEL Connection

Table 8. Slow-Start Capacitor Values and Slow-Start Time

C <sub>SS</sub> (pF)	open	2200	4700	10000	15000	22000	25000
SS Time (msec)	1.1	1.9	2.8	4.6	6.4	8.8	9.8

### 8.11 Overcurrent Protection

For protection against load faults, the LMZ30602 uses current limiting. The device is protected from overcurrent conditions by cycle-by-cycle current limiting and frequency foldback. During an overcurrent condition the output current is limited and the output voltage is reduced, as shown in Figure 26. When the overcurrent condition is removed, the output voltage returns to the established voltage, as shown in Figure 27.

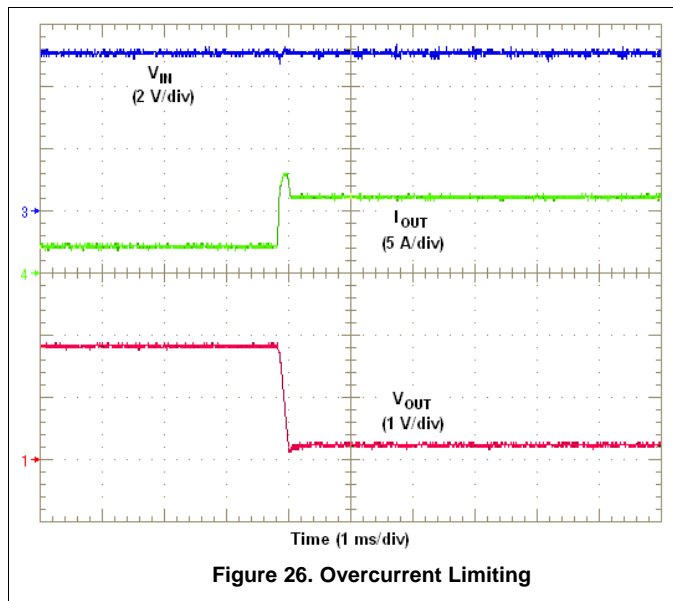

Figure 26. Overcurrent Limiting

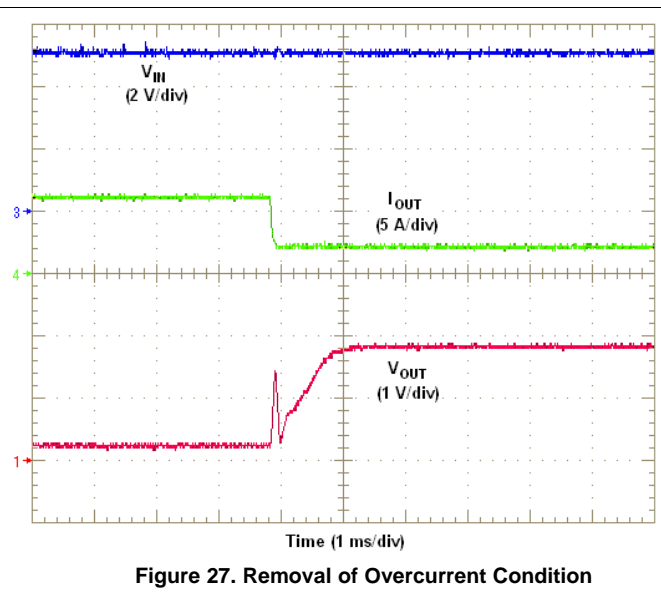

Figure 27. Removal of Overcurrent Condition

## 8.12 Synchronization (CLK)

An internal phase locked loop (PLL) has been implemented to allow synchronization between 500 kHz and 2 MHz, and to easily switch from RT mode to CLK mode. To implement the synchronization feature, connect a square wave clock signal to the RT/CLK pin with a minimum pulse width of 75 ns. The maximum clock pulse width must be calculated using Equation 2. The clock signal amplitude must transition lower than 0.4 V and higher than 2.2 V. The start of the switching cycle is synchronized to the falling edge of RT/CLK pin. In applications where both RT mode and CLK mode are needed, the device can be configured as shown in Figure 28.

Before the external clock is present, the device works in RT mode and the switching frequency is set by RT resistor ( $R_{RT}$ ). When the external clock is present, the CLK mode overrides the RT mode. The device switches from RT mode to CLK mode and the RT/CLK pin becomes high impedance as the PLL starts to lock onto the frequency of the external clock. The device will lock to the external clock frequency approximately 15  $\mu$ s after a valid clock signal is present. It is not recommended to switch from CLK mode back to RT mode because the switching frequency drops to a lower frequency before returning to the switching frequency set by  $R_{RT}$ .

$$CLK\_PW_{MAX} = \frac{0.75 \times \left( 1 - \frac{V_{OUT}}{V_{IN(min)}} \right)}{f_{SW}} \quad (2)$$

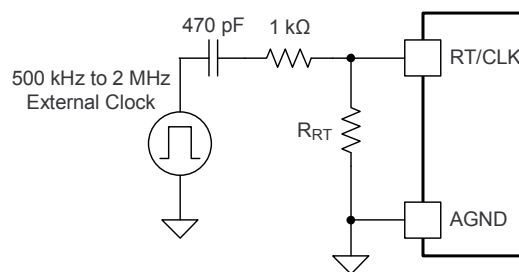

**Figure 28. CLK/RT Configuration**

The synchronization frequency must be selected based on the output voltages of the devices being synchronized. Table 9 shows the allowable frequencies for a given range of output voltages based on a resistive load. 5-V input applications requiring 1.5 A or less can synchronize to a wider frequency range. For the most efficient solution, always synchronize to the lowest allowable frequency. For example, an application requires synchronizing three LMZ30602 devices with output voltages of 1.2V@1.7A, 1.8@1.1A and 3.3V@ 1.0A, all powered from  $V_{IN} = 5V$ . Table 9 shows that all three output voltages can be synchronized to any frequency between 700 kHz to 1 MHz. For best efficiency, choose 700 kHz as the synchronization frequency.

**Table 9. Synchronization Frequency vs Output Voltage**

SYNCHRONIZATION FREQUENCY (kHz)	$R_{RT}$ (k $\Omega$ )	$V_{IN} = 5 V$				$V_{IN} = 3.3 V$	
		$I_{OUT} \leq 1.5 A$		$I_{OUT} > 1.5 A$		All $I_{OUT}$	
		$V_{OUT}$ RANGE (V)		$V_{OUT}$ RANGE (V)		$V_{OUT}$ RANGE (V)	
		MIN	MAX	MIN	MAX	MIN	MAX
500	open	0.8	1.4	0.8	0.8	0.8	1.1
550	3400	0.8	1.6	0.8	0.9	0.8	1.2
600	1800	0.8	1.9	0.8	1.1	0.8	2.0
650	1200	0.8	2.4	0.8	1.2	0.8	2.2
700	887	0.8	3.6	0.8	1.3	0.8	2.4
750	715	0.9	3.6	0.9	1.5	0.8	2.5
800	590	0.9	3.6	0.9	1.7	0.8	2.5
900	511	1.0	3.6	1.0	2.2	0.8	2.5
1000	348	1.2	3.6	1.2	2.5	0.8	2.5
1250	232	1.4	3.6	1.4	3.3	1.0	2.5
1500	174	1.7	3.6	1.7	3.6	1.1	2.5
1750	137	2.0	3.6	2.0	3.6	1.3	2.4
2000	113	2.3	3.6	2.3	3.6	1.5	2.3

### 8.13 Sequencing (SS/TR)

Many of the common power supply sequencing methods can be implemented using the SS/TR, INH and PWRGD pins. The sequential method is illustrated in [Figure 29](#) using two LMZ30602 devices. The PWRGD pin of the first device is coupled to the INH pin of the second device which enables the second power supply once the primary supply reaches regulation. Do not place a pull-up resistor on PWRGD in this configuration. [Figure 30](#) shows sequential turn-on waveforms of two LMZ30602 devices.

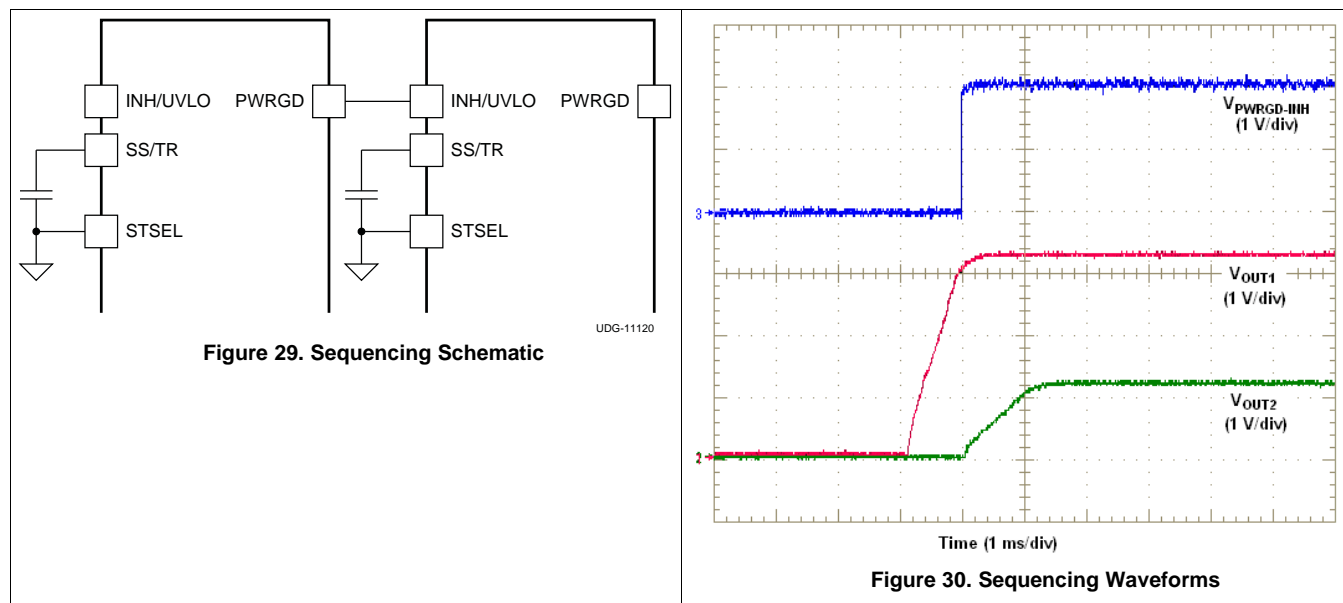

Simultaneous power supply sequencing can be implemented by connecting the resistor network of R1 and R2 shown in [Figure 31](#) to the output of the power supply that needs to be tracked or to another voltage reference source. [Figure 32](#) shows simultaneous turn-on waveforms of two LMZ30602 devices. Use [Equation 3](#) and [Equation 4](#) to calculate the values of R1 and R2.

$$R1 = \frac{(V_{OUT2} \times 12.6)}{0.803} \text{ (k}\Omega\text{)} \quad (3)$$

$$R2 = \frac{0.803 \times R1}{(V_{OUT2} - 0.803)} \text{ (k}\Omega\text{)} \quad (4)$$

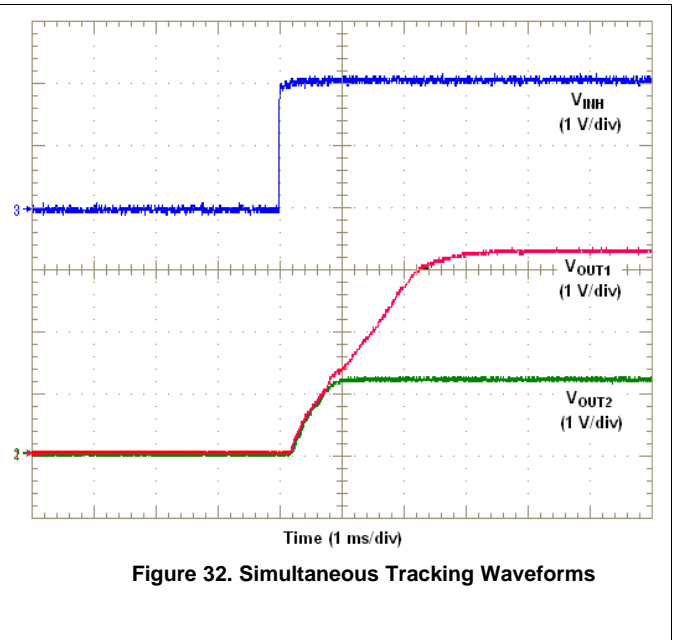
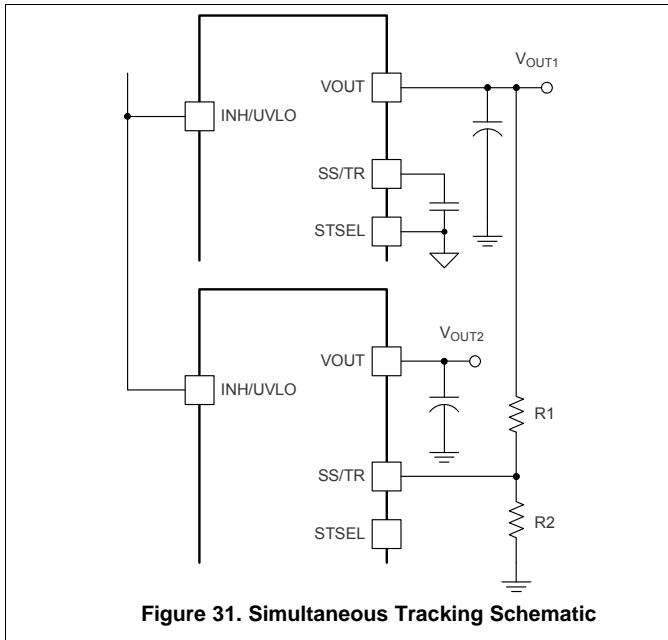

### 8.14 Programmable Undervoltage Lockout (UVLO)

The LMZ30602 implements internal UVLO circuitry on the VIN pin. The device is disabled when the VIN pin voltage falls below the internal VIN UVLO threshold. The internal VIN UVLO rising threshold is 3.135 V (max) with a typical hysteresis of 300 mV.

If an application requires a higher UVLO threshold on the VIN pin, the UVLO pin can be configured as shown in Figure 33. Table 10 lists standard values for R<sub>UVLO</sub> to adjust the VIN UVLO voltage up.

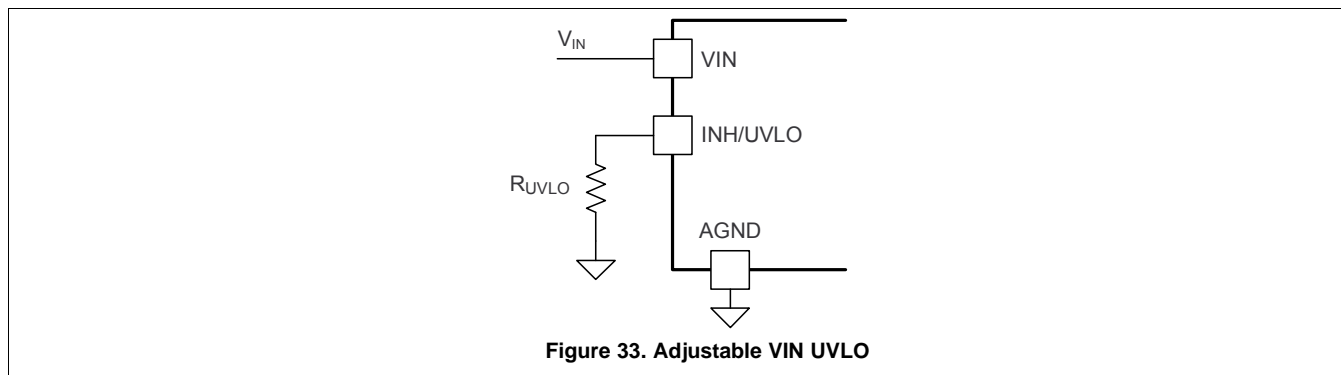

**Table 10. Standard Resistor values for Adjusting VIN UVLO**

VIN UVLO (V) (typ)	3.25	3.5	3.75	4.0	4.25	4.5	4.75
R <sub>UVLO</sub> (kΩ)	294	133	86.6	63.4	49.9	42.2	35.7
Hysteresis (mV)	325	335	345	355	365	375	385

### 8.15 Thermal Shutdown

The internal thermal shutdown circuitry forces the device to stop switching if the junction temperature exceeds 175°C typically. The device reinitiates the power up sequence when the junction temperature drops below 160°C typically.

### 8.16 EMI

The LMZ30602 is compliant with EN55022 Class B radiated emissions. Figure 34 and Figure 35 show typical examples of radiated emissions plots for the LMZ30602 operating from 5V and 3.3V respectively. Both graphs include the plots of the antenna in the horizontal and vertical positions.

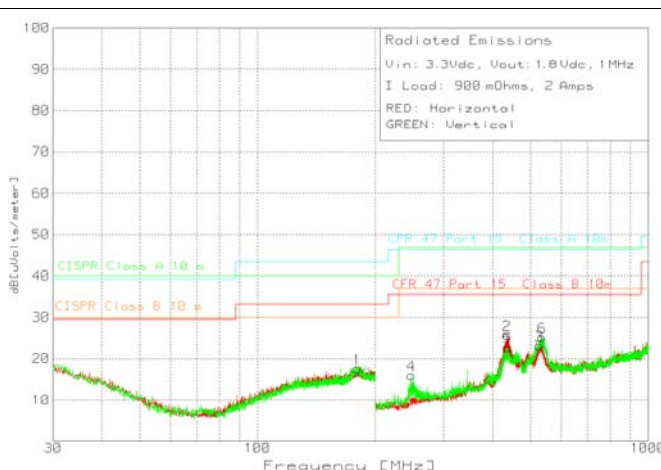
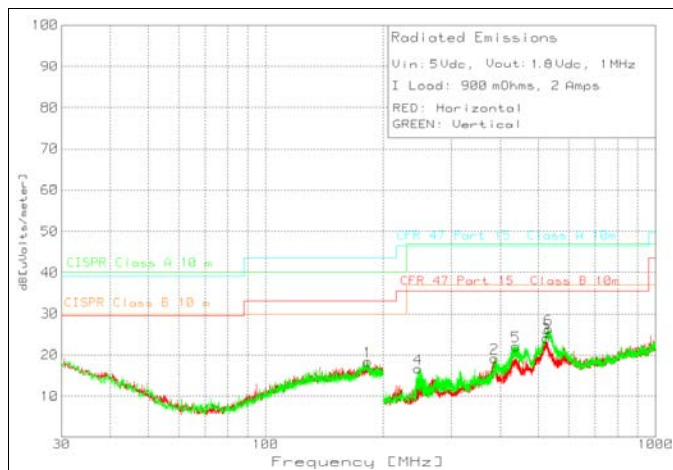

## 8.17 Layout Considerations

To achieve optimal electrical and thermal performance, an optimized PCB layout is required. Figure 36, shows a typical PCB layout. Some considerations for an optimized layout are:

- Use large copper areas for power planes (VIN, VOUT, and PGND) to minimize conduction loss and thermal stress.
- Place ceramic input and output capacitors close to the module pins to minimize high frequency noise.
- Locate additional output capacitors between the ceramic capacitor and the load.
- Place a dedicated AGND copper area beneath the LMZ30602.
- Connect the AGND and PGND copper area at one point; directly at the pin 37 PowerPad using multiple vias.
- Place  $R_{SET}$ ,  $R_{RT}$ , and  $C_{SS}$  as close as possible to their respective pins.
- Use multiple vias to connect the power planes to internal layers.

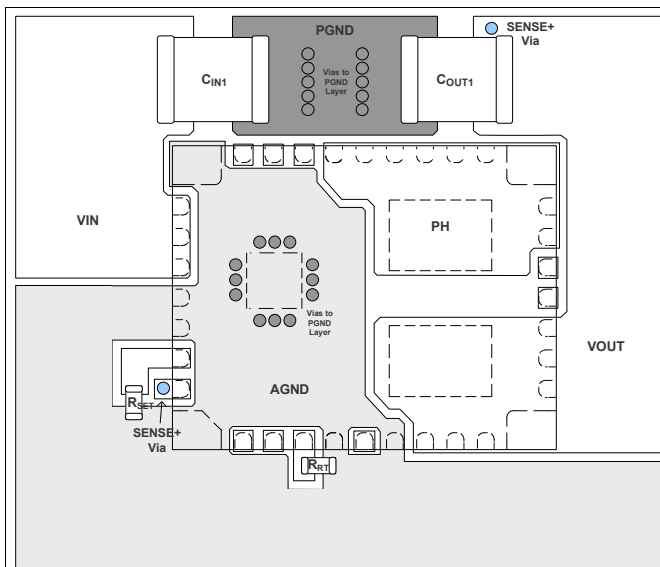

Figure 36. Typical Top-Layer Recommended Layout

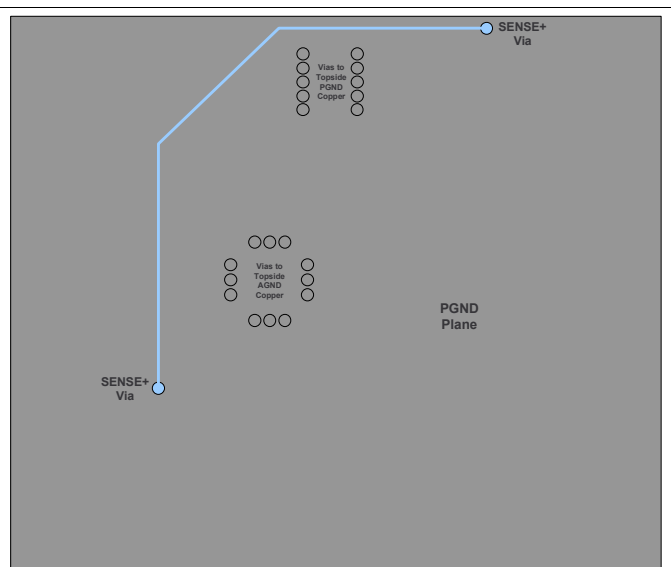

Figure 37. Typical PGND-Layer Recommended Layout



## 9 Revision History

NOTE: Page numbers for previous revisions may differ from page numbers in the current version.

### Changes from Revision A (June 2017) to Revision B Page

---

- Added WEBENCH® design links for the LMZ30602 ..... 1
  - Increased the peak reflow temperature and maximum number of reflows to JEDEC specifications for improved manufacturability ..... 2
  - Added *Device and Documentation Support* section ..... 26
  - Added *Mechanical, Packaging, and Orderable Information* section ..... 27
- 

### Changes from Original (July 2013) to Revision A Page

---

- Added peak reflow and maximum number of reflows information ..... 2
  - Changed voltage levels in [Table 9](#) ..... 20
-

## 10 Device and Documentation Support

### 10.1 Device Support

#### 10.1.1 Development Support

##### 10.1.1.1 Custom Design With WEBENCH® Tools

Click [here](#) to create a custom design using the LMZ30602 device with the WEBENCH® Power Designer.

1. Start by entering the input voltage ( $V_{IN}$ ), output voltage ( $V_{OUT}$ ), and output current ( $I_{OUT}$ ) requirements.
2. Optimize the design for key parameters such as efficiency, footprint, and cost using the optimizer dial.
3. Compare the generated design with other possible solutions from Texas Instruments.

The WEBENCH Power Designer provides a customized schematic along with a list of materials with real-time pricing and component availability.

In most cases, these actions are available:

- Run electrical simulations to see important waveforms and circuit performance
- Run thermal simulations to understand board thermal performance
- Export customized schematic and layout into popular CAD formats
- Print PDF reports for the design, and share the design with colleagues

Get more information about WEBENCH tools at [www.ti.com/WEBENCH](http://www.ti.com/WEBENCH).

### 10.2 Receiving Notification of Documentation Updates

To receive notification of documentation updates, navigate to the device product folder on ti.com. In the upper right corner, click on *Alert me* to register and receive a weekly digest of any product information that has changed. For change details, review the revision history included in any revised document.

### 10.3 Community Resources

The following links connect to TI community resources. Linked contents are provided "AS IS" by the respective contributors. They do not constitute TI specifications and do not necessarily reflect TI's views; see TI's [Terms of Use](#).

**TI E2E™ Online Community** *TI's Engineer-to-Engineer (E2E) Community*. Created to foster collaboration among engineers. At [e2e.ti.com](http://e2e.ti.com), you can ask questions, share knowledge, explore ideas and help solve problems with fellow engineers.

**Design Support** *TI's Design Support* Quickly find helpful E2E forums along with design support tools and contact information for technical support.

### 10.4 Trademarks

E2E is a trademark of Texas Instruments.

WEBENCH is a registered trademark of Texas Instruments.

All other trademarks are the property of their respective owners.

### 10.5 Electrostatic Discharge Caution



This integrated circuit can be damaged by ESD. Texas Instruments recommends that all integrated circuits be handled with appropriate precautions. Failure to observe proper handling and installation procedures can cause damage.

ESD damage can range from subtle performance degradation to complete device failure. Precision integrated circuits may be more susceptible to damage because very small parametric changes could cause the device not to meet its published specifications.

### 10.6 Glossary

[SLYZ022](#) — *TI Glossary*.

This glossary lists and explains terms, acronyms, and definitions.

## 11 Mechanical, Packaging, and Orderable Information

The following pages include mechanical, packaging, and orderable information. This information is the most current data available for the designated devices. This data is subject to change without notice and revision of this document. For browser-based versions of this data sheet, refer to the left-hand navigation.

### 11.1 Tape and Reel Information

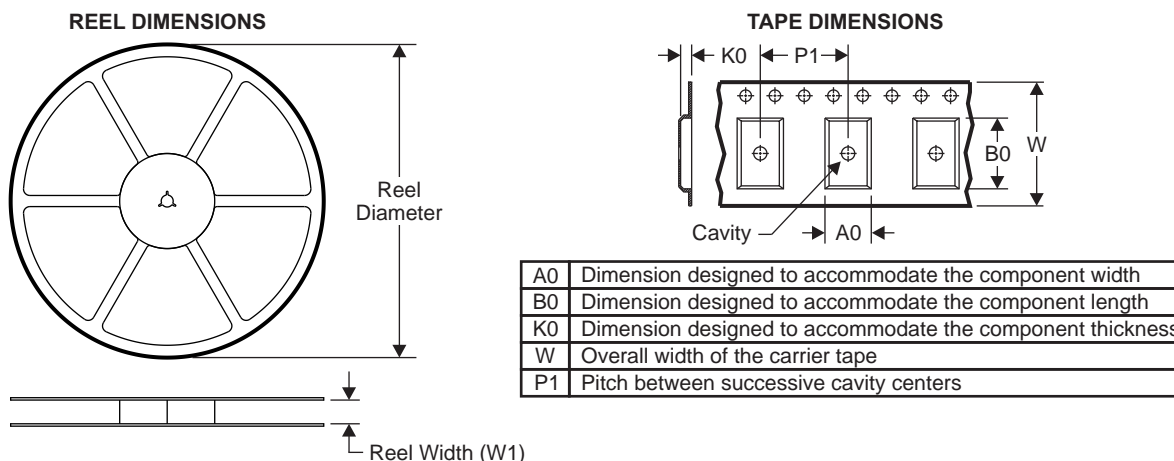

#### QUADRANT ASSIGNMENTS FOR PIN 1 ORIENTATION IN TAPE

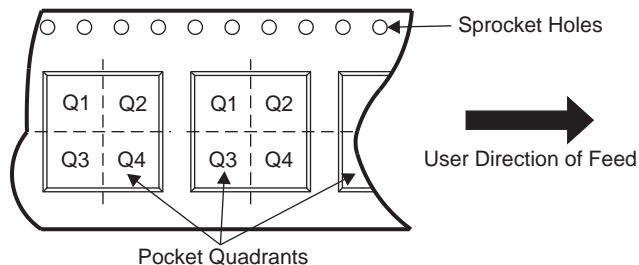

Device	Package Type	Package Drawing	Pins	SPQ	Reel Diameter (mm)	Reel Width W1 (mm)	A0 (mm)	B0 (mm)	K0 (mm)	P1 (mm)	W (mm)	Pin1 Quadrant
LMZ30602RKGR	B1QFN	RKG	39	500	330.0	24.4	9.35	15.35	3.1	16.0	24.0	Q1
LMZ30602RKGT	B1QFN	RKG	39	250	330.0	24.4	9.35	15.35	3.1	16.0	24.0	Q1

**LMZ30602**

SNVS997B –JULY 2013–REVISED APRIL 2018

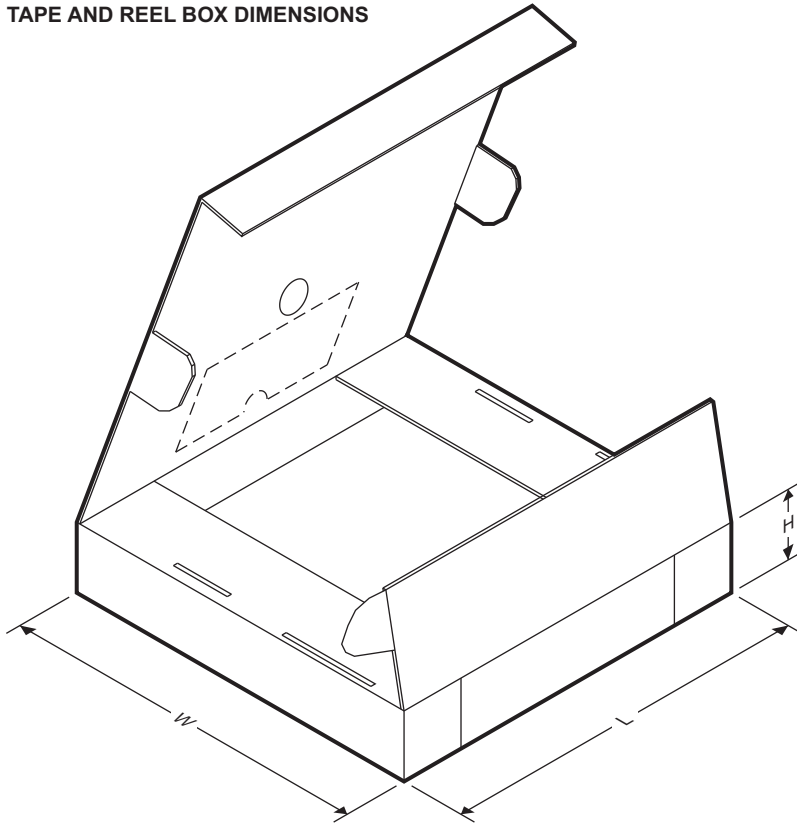
[www.ti.com](http://www.ti.com)
**TAPE AND REEL BOX DIMENSIONS**

Device	Package Type	Package Drawing	Pins	SPQ	Length (mm)	Width (mm)	Height (mm)
LMZ30602RKGR	B1QFN	RKG	39	500	383.0	353.0	58.0
LMZ30602RKGT	B1QFN	RKG	39	250	383.0	353.0	58.0



# MECHANICAL DATA

RKG (R-PB1QFN-N39)

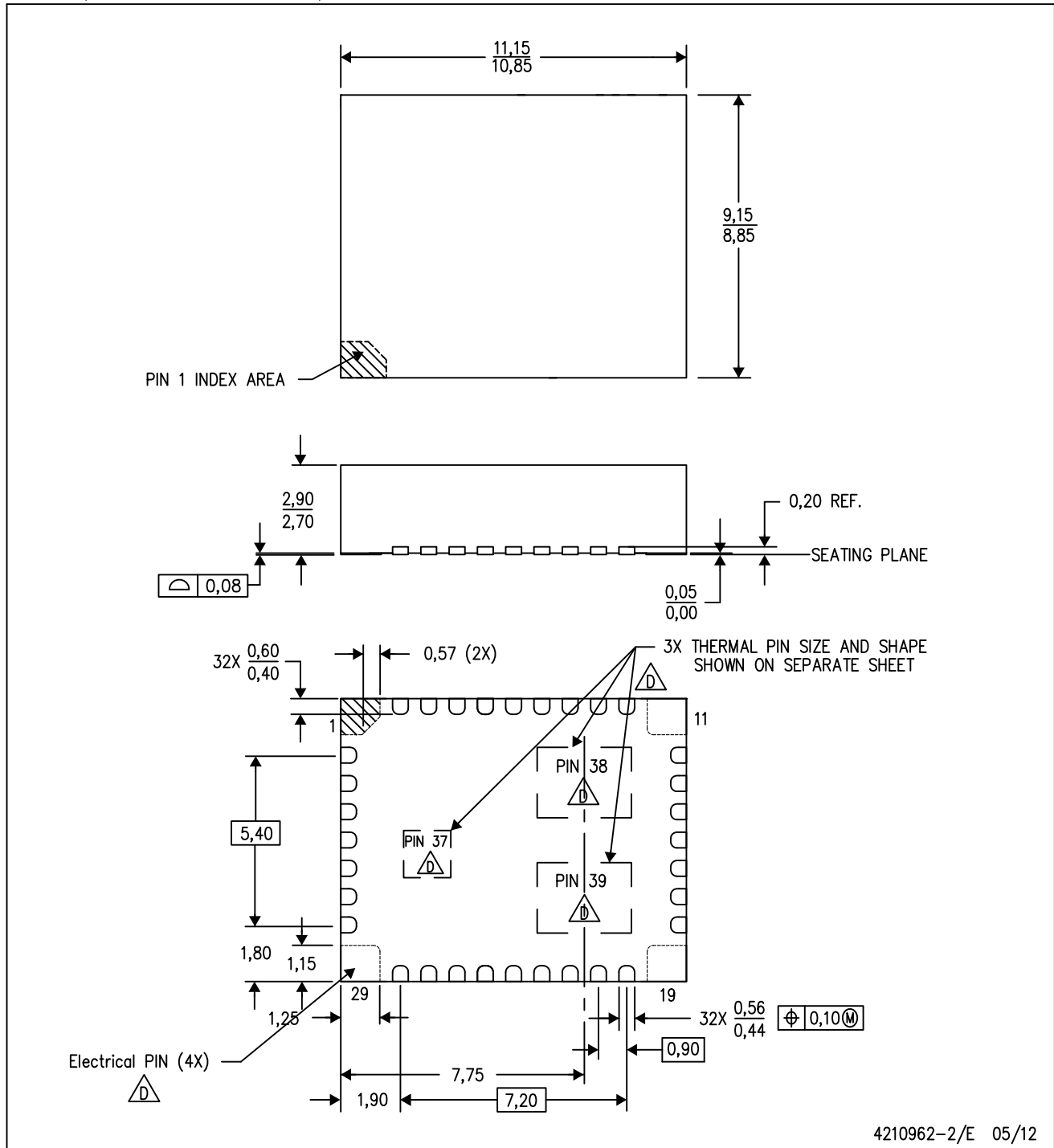
PLASTIC QUAD FLATPACK NO-LEAD



4210962-2/E 05/12

- NOTES:
- A. All linear dimensions are in millimeters. Dimensioning and tolerancing per ASME Y14.5M-1994.
  - B. This drawing is subject to change without notice.
  - C. Quad Flatpack, No-leads (QFN) package configuration.
  -  The package thermal pad must be soldered to the board for thermal and mechanical performance.
  - E. See the additional figure in the Product Data Sheet for details regarding the exposed thermal pad features and dimensions.
  -  The package thermal performance may be enhanced by bonding the thermal pad to an external thermal plane.



RKG (S-PB1QFN-N39)

PLASTIC QUAD FLATPACK NO-LEAD

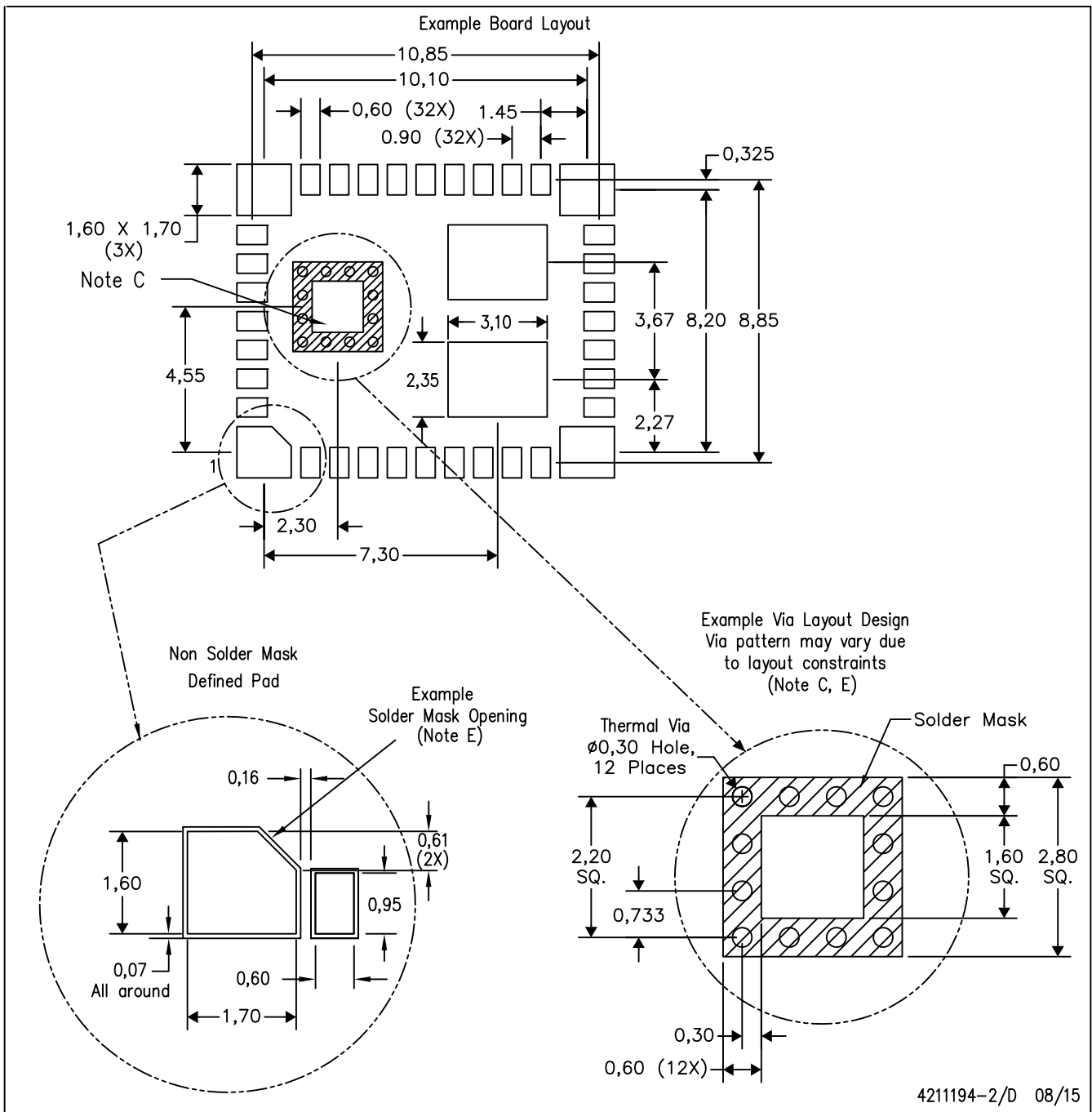

- NOTES:
- A. All linear dimensions are in millimeters.
  - B. This drawing is subject to change without notice.
  - C. This package is designed to be soldered to a thermal pad on the board. Refer to Application Note, Quad Flat-Pack Packages, Texas Instruments Literature No. SLUA271, and also the Product Data Sheets for specific thermal information, via requirements, and recommended board layout. These documents are available at [www.ti.com](http://www.ti.com) <<http://www.ti.com>>.
  - D. Laser cutting apertures with trapezoidal walls and also rounding corners will offer better paste release. Customers should contact their board assembly site for stencil design recommendations. Refer to IPC 7525 for stencil design considerations.
  - E. Customers should contact their board fabrication site for minimum solder mask web tolerances between signal pads.

RKG (S-PB1QFN-N39)

PLASTIC QUAD FLATPACK NO-LEAD

Example Stencil Design (Note D)  
Stencil Thickness = 0,125mm

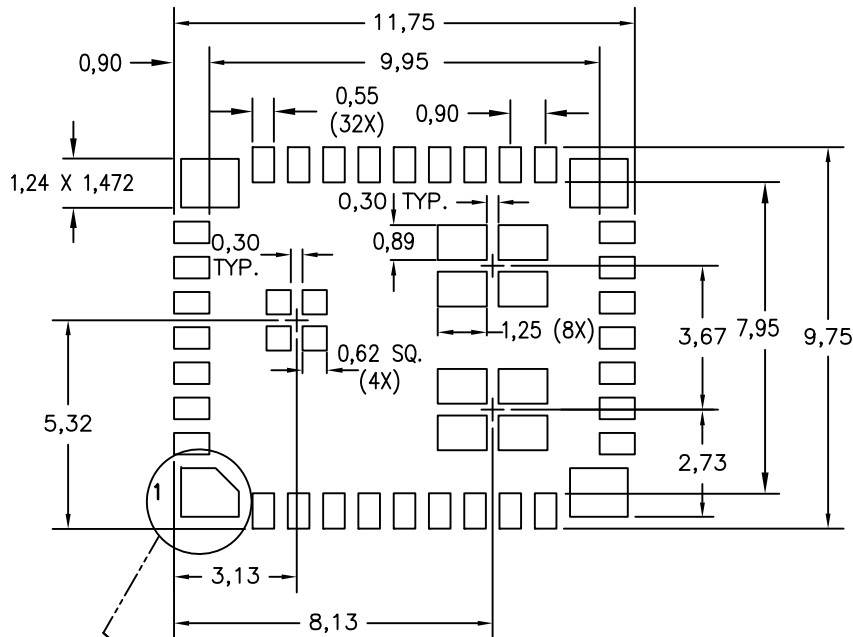

60% solder coverage on thermal pads

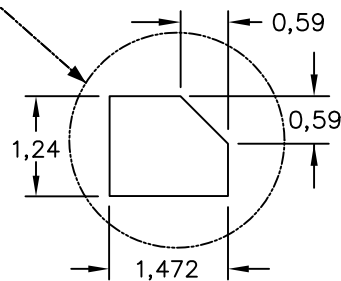

4211194-3/D 08/15

- NOTES:
- A. All linear dimensions are in millimeters.
  - B. This drawing is subject to change without notice.
  - C. This package is designed to be soldered to a thermal pad on the board. Refer to Application Note, Quad Flat-Pack Packages, Texas Instruments Literature No. SLUA271, and also the Product Data Sheets for specific thermal information, via requirements, and recommended board layout. These documents are available at [www.ti.com](http://www.ti.com) <<http://www.ti.com>>.
  - D. Laser cutting apertures with trapezoidal walls and also rounding corners will offer better paste release. Customers should contact their board assembly site for stencil design recommendations. Refer to IPC 7525 for stencil design considerations.
  - E. Customers should contact their board fabrication site for minimum solder mask web tolerances between signal pads.



**PACKAGING INFORMATION**

Orderable part number	Status (1)	Material type (2)	Package   Pins	Package qty   Carrier	RoHS (3)	Lead finish/ Ball material (4)	MSL rating/ Peak reflow (5)	Op temp (°C)	Part marking (6)
<a href="#">LMZ30602RKGR</a>	Active	Production	B1QFN (RKG)   39	500   LARGE T&R	Exempt	NIPDAU	Level-3-250C-168 HR	-40 to 85	LMZ30602
LMZ30602RKGR.A	Active	Production	B1QFN (RKG)   39	500   LARGE T&R	Exempt	NIPDAU	Level-3-250C-168 HR	-40 to 125	LMZ30602
LMZ30602RKGR.B	Active	Production	B1QFN (RKG)   39	500   LARGE T&R	-	Call TI	Call TI	-40 to 85	
<a href="#">LMZ30602RKGT</a>	Active	Production	B1QFN (RKG)   39	250   SMALL T&R	Exempt	NIPDAU	Level-3-250C-168 HR	-40 to 85	LMZ30602
LMZ30602RKGT.A	Active	Production	B1QFN (RKG)   39	250   SMALL T&R	Exempt	NIPDAU	Level-3-250C-168 HR	-40 to 125	LMZ30602
LMZ30602RKGT.B	Active	Production	B1QFN (RKG)   39	250   SMALL T&R	-	Call TI	Call TI	-40 to 85	

<sup>(1)</sup> **Status:** For more details on status, see our [product life cycle](#).

<sup>(2)</sup> **Material type:** When designated, preproduction parts are prototypes/experimental devices, and are not yet approved or released for full production. Testing and final process, including without limitation quality assurance, reliability performance testing, and/or process qualification, may not yet be complete, and this item is subject to further changes or possible discontinuation. If available for ordering, purchases will be subject to an additional waiver at checkout, and are intended for early internal evaluation purposes only. These items are sold without warranties of any kind.

<sup>(3)</sup> **RoHS values:** Yes, No, RoHS Exempt. See the [TI RoHS Statement](#) for additional information and value definition.

<sup>(4)</sup> **Lead finish/Ball material:** Parts may have multiple material finish options. Finish options are separated by a vertical ruled line. Lead finish/Ball material values may wrap to two lines if the finish value exceeds the maximum column width.

<sup>(5)</sup> **MSL rating/Peak reflow:** The moisture sensitivity level ratings and peak solder (reflow) temperatures. In the event that a part has multiple moisture sensitivity ratings, only the lowest level per JEDEC standards is shown. Refer to the shipping label for the actual reflow temperature that will be used to mount the part to the printed circuit board.

<sup>(6)</sup> **Part marking:** There may be an additional marking, which relates to the logo, the lot trace code information, or the environmental category of the part.

Multiple part markings will be inside parentheses. Only one part marking contained in parentheses and separated by a "~" will appear on a part. If a line is indented then it is a continuation of the previous line and the two combined represent the entire part marking for that device.

**Important Information and Disclaimer:** The information provided on this page represents TI's knowledge and belief as of the date that it is provided. TI bases its knowledge and belief on information provided by third parties, and makes no representation or warranty as to the accuracy of such information. Efforts are underway to better integrate information from third parties. TI has taken and continues to take reasonable steps to provide representative and accurate information but may not have conducted destructive testing or chemical analysis on incoming materials and chemicals. TI and TI suppliers consider certain information to be proprietary, and thus CAS numbers and other limited information may not be available for release.

In no event shall TI's liability arising out of such information exceed the total purchase price of the TI part(s) at issue in this document sold by TI to Customer on an annual basis.



## IMPORTANT NOTICE AND DISCLAIMER

TI PROVIDES TECHNICAL AND RELIABILITY DATA (INCLUDING DATASHEETS), DESIGN RESOURCES (INCLUDING REFERENCE DESIGNS), APPLICATION OR OTHER DESIGN ADVICE, WEB TOOLS, SAFETY INFORMATION, AND OTHER RESOURCES "AS IS" AND WITH ALL FAULTS, AND DISCLAIMS ALL WARRANTIES, EXPRESS AND IMPLIED, INCLUDING WITHOUT LIMITATION ANY IMPLIED WARRANTIES OF MERCHANTABILITY, FITNESS FOR A PARTICULAR PURPOSE OR NON-INFRINGEMENT OF THIRD PARTY INTELLECTUAL PROPERTY RIGHTS.

These resources are intended for skilled developers designing with TI products. You are solely responsible for (1) selecting the appropriate TI products for your application, (2) designing, validating and testing your application, and (3) ensuring your application meets applicable standards, and any other safety, security, regulatory or other requirements.

These resources are subject to change without notice. TI grants you permission to use these resources only for development of an application that uses the TI products described in the resource. Other reproduction and display of these resources is prohibited. No license is granted to any other TI intellectual property right or to any third party intellectual property right. TI disclaims responsibility for, and you fully indemnify TI and its representatives against any claims, damages, costs, losses, and liabilities arising out of your use of these resources.

TI's products are provided subject to [TI's Terms of Sale](#), [TI's General Quality Guidelines](#), or other applicable terms available either on [ti.com](#) or provided in conjunction with such TI products. TI's provision of these resources does not expand or otherwise alter TI's applicable warranties or warranty disclaimers for TI products. Unless TI explicitly designates a product as custom or customer-specified, TI products are standard, catalog, general purpose devices.

TI objects to and rejects any additional or different terms you may propose.

Copyright © 2025, Texas Instruments Incorporated

Last updated 10/2025