

Precision Remote Diode Digital Temperature Sensor with TruTherm® BJT Beta Compensation Technology for 45nm Process

Check for Samples: [LM95245](#)

FEATURES

- Remote and Local Temperature Channels
- Targeted for Intel 45nm Processor Diodes
- Two Formats: -128°C to $+127.875^{\circ}\text{C}$ and 0°C to 255.875°C
- Digital Filter for Remote Channel
- Programmable TCRIT and OS Thresholds
- Programmable Shared Hysteresis Register
- Diode Fault Detection
- Mask, Offset, and Status Registers
- SMBus 2.0 Compatible Interface, Supports TIMEOUT
- Programmable Conversion Rate for Best Power Consumption
- Three-Level Address Pin
- Standby Mode One-Shot Conversion Control
- Pin-for-Pin Compatible With the LM95235 and LM86, LM89, LM99
- 8-Pin VSSOP and SOIC Packages

APPLICATIONS

- Processor/Computer System Thermal Management (For Example, Laptops, Desktops, Workstations, Servers)
- Electronic Test Equipment
- Office Electronics

KEY SPECIFICATIONS

- Supply Voltage 3.0 to 3.6 V
- Supply Current, Conv. Rate = 1 Hz 350 μA (typ)
- Remote Diode Temperature Accuracy
 - $T_A = 25^{\circ}\text{C}$ to 85°C ; $T_D = 50^{\circ}\text{C}$ to 105°C , $\pm 0.75^{\circ}\text{C}$ (max)
 - $T_A = 25^{\circ}\text{C}$ to 85°C ; $T_D = 40^{\circ}\text{C}$ to 125°C , $\pm 1.5^{\circ}\text{C}$ (max)
- Local Temperature Accuracy
 - $T_A = 25^{\circ}\text{C}$ to 100°C , $\pm 2.0^{\circ}\text{C}$ (max)
- Conversion Rate, Both Channels 16 to 0.4 Hz

DESCRIPTION

The LM95245 is an 11-bit digital temperature sensor with a 2-wire System Management Bus (SMBus) interface and TruTherm technology that can monitor the temperature of a remote diode as well as its own temperature. The LM95245 can be used to very accurately monitor the temperature of external devices such as microprocessors. TruTherm technology allows the LM95245 to precisely monitor thermal diodes found in 90 nm and smaller geometry processes. The LM95245 is specifically targeted for Intel processors on 45nm process. LM95245 reports temperature in two different formats for $+127.875^{\circ}\text{C}/-128^{\circ}\text{C}$ range and $0^{\circ}\text{C}/255^{\circ}\text{C}$ range. The LM95245 $\overline{T_CRIT}$ and \overline{OS} outputs are asserted when either unmasked channel exceeds its programmed limit and can be used to shutdown the system, to turn on the system fans, or as a microcontroller interrupt function. The current status of the $\overline{T_CRIT}$ and \overline{OS} pins can be read back from the status registers via the SMBus interface. All limits have a shared programmable hysteresis register.

The remote temperature channel of the LM95245 has a programmable digital filter. The LM95245 is targeted for a typical Intel® processor on a 45 nm, 65 nm or 90nm process, and has an offset register for maximum flexibility and best accuracy.

The LM95245 has a three-level address pin to connect up to 3 devices to the same SMBus master, that is shared with the \overline{OS} output. The LM95245 has a programmable conversion rate register and a standby mode to save power. One conversion can be triggered in standby mode by writing to the one-shot register.



Please be aware that an important notice concerning availability, standard warranty, and use in critical applications of Texas Instruments semiconductor products and disclaimers thereto appears at the end of this data sheet.

All trademarks are the property of their respective owners.

Connection Diagram

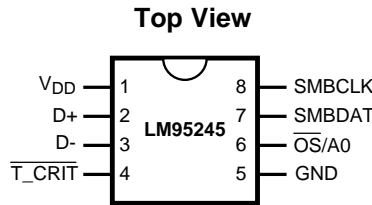

Figure 1. VSSOP-8 and SOIC-8 Packages see package numbers DGK0008A, D0008A

Simplified Block Diagram

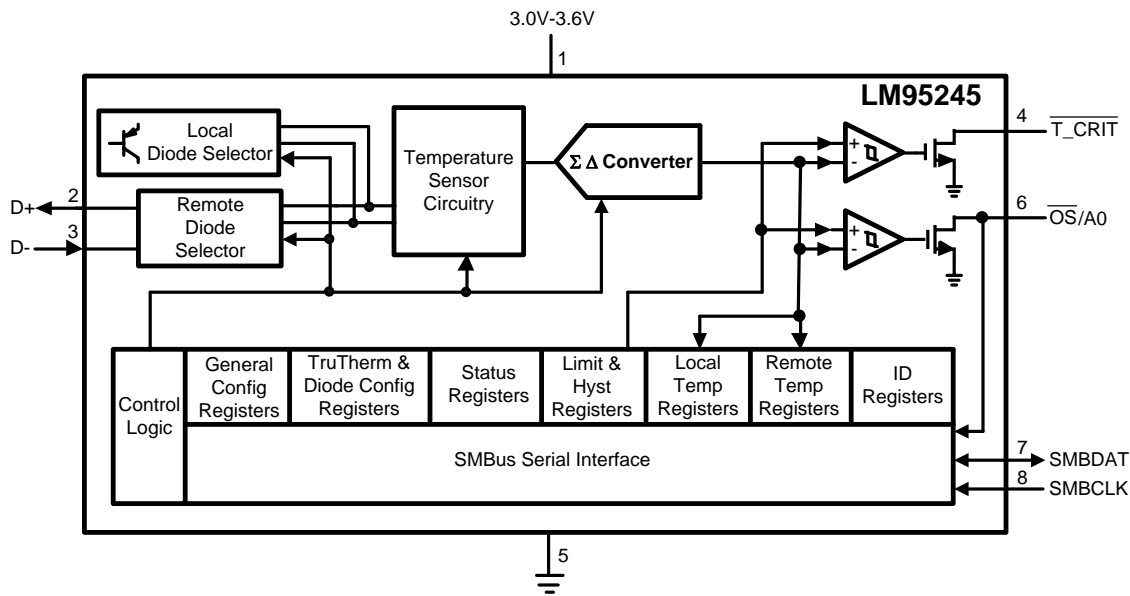
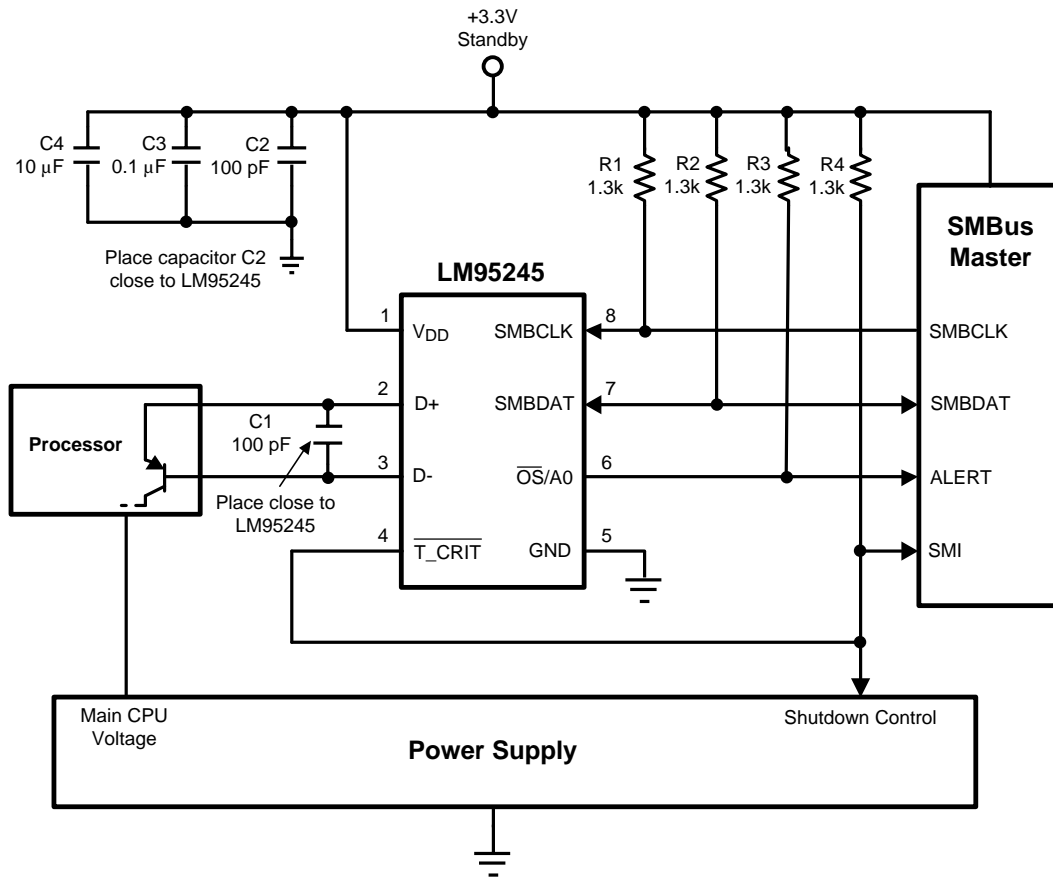

Table 1. Pin Descriptions

Pin Number	Name	Type	Description
1	V _{DD}	Power	Device power supply. Requires bypass capacitor of 10 μF in parallel with 0.1 μF and 100 pF. Place 100 pF closest to device pin.
2	D+	Analog Input/Output	Positive input from the thermal diode.
3	D-	Analog Input/Output	Negative input from the thermal diode.
4	T _{CRIT}	Digital Output	Critical temperature output. Open-drain output requires pull-up resistor. Active low.
5	GND	Ground	Device ground.
6	OS/A0	Digital Input/Output	Over-temperature shutdown comparator output or SMBus slave address input. Defaults as an SMBus slave address input that selects one of three addresses. Can be tied to V _{DD} , GND, or to the middle of a resistor divider connected between V _{DD} and GND. When programmed as an OS comparator output it is active low and open drain.
7	SMBDAT	Digital Input/Output	SMBus interface data pin. Open-drain output requires pull-up resistor.
8	SMBCLK	Digital Input	SMBus interface clock pin.

Typical Application





These devices have limited built-in ESD protection. The leads should be shorted together or the device placed in conductive foam during storage or handling to prevent electrostatic damage to the MOS gates.

Absolute Maximum Ratings ⁽¹⁾⁽²⁾

Supply Voltage, V_{DD}	-0.3V to 6.0V	
Voltage at SMBDAT, SMBCLK, $\overline{T_CRIT}$, $\overline{OS/A0}$ Pins	-0.5V to 6.0V	
Voltage at Other Pins	($V_{DD} + 0.3V$)	
Input Current at D- Pin ⁽³⁾	± 1 mA	
Input Current at All Other Pins ⁽³⁾	± 5 mA	
Output Sink Current, SMBDAT, $\overline{T_Crit}$, \overline{OS} Pins	10 mA	
Package Input Current ⁽³⁾	30 mA	
ESD Susceptibility ⁽⁴⁾	Human Body Model	2500V
	Machine Model	250V
	Charged Device Model	1000V
Junction Temperature ⁽⁵⁾	+125°C	
Storage Temperature	-65°C to +150°C	

- (1) Absolute Maximum Ratings indicate limits beyond which damage to the device may occur. Operating Ratings indicate conditions for which the device is guaranteed to be functional, but do not guarantee specific performance limits. For guaranteed specifications and test conditions, see the Electrical Characteristics. The guaranteed specifications apply only for the test conditions listed. Some performance characteristics may degrade when the device is not operated under the listed test conditions. Operation of the device beyond the maximum Operating Ratings is not recommended.
- (2) Soldering process must comply with Reflow Temperature Profile specifications. Refer to www.ti.com/packaging. Reflow temperature profiles are different for packages containing lead (Pb) than for those that do not.
- (3) When the input voltage (V_I) at any pin exceeds the power supplies ($V_I < GND$ or $V_I > V_{DD}$), the current at that pin should be limited to 5 mA. Parasitic components and or ESD protection circuitry are shown in Table 2 for the LM95245's pins. Care should be taken not to forward bias the parasitic diodes on pins 2 and 3. Doing so by more than 50 mV may corrupt the temperature measurements. SNP refers to Snap-back device.
- (4) Human body model (HBM) is a charged 100 pF capacitor discharged into a 1.5 kΩ resistor. Machine model (MM), is a charged 200 pF capacitor discharged directly into each pin. Charged Device Model (CDM) simulates a pin slowly acquiring charge (such as from a device sliding down the feeder in an automated assembler) then rapidly being discharged.
- (5) Thermal resistance junction-to-ambient when attached to a printed circuit board with 1 oz. foil and no airflow is: θ_{JA} for VSSOP-8 package = 210°C/W, θ_{JA} for SOIC-8 package = 168°C/W

Table 2. ESD Protection

Pin No.	Label	Circuit	Pin ESD Protection Structure Circuits
1	V_{DD}	B	
2	D+	A	
3	D-	A	
4	$\overline{T_CRIT}$	C	
5	GND	B	
6	$\overline{OS/A0}$	C	
7	SMBDAT	C	
8	SMBCLK	C	

Operating Ratings⁽¹⁾

Operating Temperature Range	-40°C to +125°C
Electrical Characteristics Temperature Range, $T_{MIN} \leq T_A \leq T_{MAX}$	-40°C $\leq T_A \leq$ +85°C
Supply Voltage (V_{DD})	+3.0V to +3.6V

- (1) Absolute Maximum Ratings indicate limits beyond which damage to the device may occur. Operating Ratings indicate conditions for which the device is guaranteed to be functional, but do not guarantee specific performance limits. For guaranteed specifications and test conditions, see the Electrical Characteristics. The guaranteed specifications apply only for the test conditions listed. Some performance characteristics may degrade when the device is not operated under the listed test conditions. Operation of the device beyond the maximum Operating Ratings is not recommended.

Temperature-to-Digital Converter Characteristics

Unless otherwise noted, these specifications apply for $V_{DD} = +3.0$ Vdc to 3.6 Vdc. **Boldface limits apply for $T_A = T_J = T_{MIN} \leq T_A \leq T_{MAX}$** ; all other limits $T_A = T_J = +25^\circ\text{C}$, unless otherwise noted. T_J is the junction temperature of the LM95245. T_D is the junction temperature of the remote thermal diode.

Parameter	Test Conditions	Typ ⁽¹⁾	Limits ⁽²⁾	Unit (Limit)	
Temperature Accuracy Using Local Diode ⁽³⁾	$T_A = 25^\circ\text{C}$ to $+100^\circ\text{C}$	± 1	± 2	°C (max)	
	$T_A = -40^\circ\text{C}$ to $+25^\circ\text{C}$		± 6	°C (max)	
Temperature Accuracy Using Remote Diode ⁽⁴⁾	$T_A = +25^\circ\text{C}$ to $+85^\circ\text{C}$; $T_D = +50^\circ\text{C}$ to $+105^\circ\text{C}$	45nm Intel Processor	± 0.5	± 0.75	°C (max)
	$T_A = +25^\circ\text{C}$ to $+85^\circ\text{C}$; $T_D = +40^\circ\text{C}$ to $+120^\circ\text{C}$	45nm Intel Processor	± 0.75	± 1.5	°C (max)
	$T_A = -40^\circ\text{C}$ to $+25^\circ\text{C}$; $T_D = +25^\circ\text{C}$ to $+125^\circ\text{C}$	45nm Intel Processor		± 3.0	°C (max)
Remote Diode Measurement Resolution	Digital Filter Off	11		Bits	
	Digital Filter On	0.125		°C	
Local Diode Measurement Resolution		13		Bits	
		0.03125		°C	
Conversion Time, Fastest Setting ⁽⁵⁾	Local and Remote Channels	63	72	ms (max)	
	Local or Remote Channels	33		ms	
Quiescent Current	SMBus Inactive, 1 Hz conversion rate ⁽⁶⁾	350	670	μA (max)	
	Standby Mode	300		μA	
D- Source Voltage		400		mV	
External Diode Current Source	High-level	172	225	μA (max)	
	Low-level	10.75		μA	
Diode Source Current Ratio		16			
Power-On Reset Voltage			2.8	V (max)	
			1.6	V (min)	
$\overline{T_CRIT}$ Pin Temperature Threshold	Default	+110		°C	
\overline{OS} Pin Temperature Threshold	Default	+85		°C	

- (1) Typical figures are at $T_A = 25^\circ\text{C}$ and represent most likely parametric norms at the time of product characterization. The typical specifications are not guaranteed.
- (2) Limits are guaranteed to TI's AOQL (Average Outgoing Quality Level).
- (3) Local temperature accuracy does not include the effects of self-heating. The rise in temperature due to self-heating is the product of the internal power dissipation of the LM95245 and the thermal resistance. See ⁽¹⁾ for the thermal resistance to be used in the self-heating calculation.
- (4) The accuracy of the LM95245 is guaranteed when using a typical thermal diode of an Intel processor on a 45 nm process, as selected in the Remote Diode Model Select register. See typical performance curve for performance with Intel processor on a 65nm or 90nm process.
- (5) This specification is provided only to indicate how often temperature data is updated. The LM95245 can be read at any time without regard to conversion state (and will yield last conversion result).
- (6) Quiescent current will not increase substantially when the SMBus is active.

Logic Electrical Characteristics

Digital DC Characteristics

Unless otherwise noted, these specifications apply for $V_{DD} = +3.0$ Vdc to 3.6 Vdc. **Boldface limits apply for $T_A = T_J = T_{MIN}$ to T_{MAX}** ; all other limits $T_A = T_J = +25^\circ\text{C}$, unless otherwise noted.

Parameter		Test Conditions	Typ ⁽¹⁾	Limits ⁽²⁾	Unit (Limit)
SMBDAT, SMBCLK INPUTS					
$V_{IN(1)}$	Logical "1" Input Voltage			2.1	V (min)
$V_{IN(0)}$	Logical "0" Input Voltage			0.8	V (max)
$V_{IN(HYST)}$	SMBDAT and SMBCLK Digital Input Hysteresis		400		mV
$I_{IN(1)}$	Logical "1" Input Current	$V_{IN} = V_{DD}$	-0.005	-10	μA (max)
$I_{IN(0)}$	Logical "0" Input Current	$V_{IN} = 0$ V	0.005	+10	μA (max)
C_{IN}	Input Capacitance		5		pF
A0 DIGITAL INPUT					
V_{IH}	Input High Voltage			$0.90 \times V_{DD}$	V (min)
V_{IM}	Input Middle Voltage			$0.57 \times V_{DD}$	V (max)
				$0.43 \times V_{DD}$	V (min)
V_{IL}	Input Low Voltage			$0.10 \times V_{DD}$	V (max)
$I_{IN(1)}$	Logical "1" Input Current	$V_{IN} = V_{DD}$	-0.005	-10	μA (max)
$I_{IN(0)}$	Logical "0" Input Current	$V_{IN} = 0$ V	0.005	+10	μA (max)
C_{IN}	Input Capacitance		5		pF
SMBDAT, $\overline{T_CRIT}$, \overline{OS} DIGITAL OUTPUTS					
I_{OH}	High Level Output Leakage Current	$V_{OUT} = V_{DD}$		10	μA (max)
$V_{OL(\overline{T_CRIT}, \overline{OS})}$	$\overline{T_CRIT}$, \overline{OS} Low Level Output Voltage	$I_{OL} = 6$ mA		0.4	V (max)
$V_{OL(SMBDAT)}$	SMBDAT Low Level Output Voltage	$I_{OL} = 4$ mA $I_{OL} = 6$ mA		0.4	V (max)
				0.6	V (max)
C_{OUT}	Digital Output Capacitance		5		pF

- (1) Typical figures are at $T_A = 25^\circ\text{C}$ and represent most likely parametric norms at the time of product characterization. The typical specifications are not guaranteed.
- (2) Limits are guaranteed to TI's AOQL (Average Outgoing Quality Level).

SMBus Digital Switching Characteristics

Unless otherwise noted, these specifications apply for $V_{DD} = +3.0 \text{ Vdc}$ to $+3.6 \text{ Vdc}$, C_L (load capacitance) on output lines = 80 pF. **Boldface limits apply for $T_A = T_J = T_{MIN}$ to T_{MAX}** ; all other limits $T_A = T_J = +25^\circ\text{C}$, unless otherwise noted. The switching characteristics of the LM95245 fully meet or exceed the published specifications of the SMBus version 2.0. The following parameters are the timing relationships between SMBCLK and SMBDAT signals related to the LM95245. They adhere to, but are not necessarily, the SMBus specifications.

Parameter		Test Conditions	Typ ⁽¹⁾	Limits ⁽²⁾	Unit (Limit)
f_{SMB}	SMBus Clock Frequency			100 10	kHz (max) kHz (min)
t_{LOW}	SMBus Clock Low Time	from $V_{IN(0)max}$ to $V_{IN(0)max}$		4.7 25	μs (min) ms (max)
t_{HIGH}	SMBus Clock High Time	from $V_{IN(1)min}$ to $V_{IN(1)min}$		4.0	μs (min)
$t_{R,SMB}$	SMBus Rise Time	⁽³⁾	1		μs (max)
$t_{F,SMB}$	SMBus Fall Time	⁽⁴⁾	0.3		μs (max)
t_{OF}	Output Fall Time	$C_L = 400 \text{ pF}$ $I_O = 3 \text{ mA}$, ⁽⁴⁾		250	ns (max)
$t_{TIMEOUT}$	SMBDAT and SMBCLK Time Low for Reset of Serial Interface ⁽⁵⁾			25 35	ms (min) ms (max)
$t_{SU,DAT}$	Data In Setup Time to SMBCLK High			250	ns (min)
$t_{HD,DAT}$	Data Out Stable after SMBCLK Low			300 1075	ns (min) ns (max)
$t_{HD,STA}$	Start Condition SMBDAT Low to SMBCLK Low (Start condition hold before the first clock falling edge)			100	ns (min)
$t_{SU,STO}$	Stop Condition SMBCLK High to SMBDAT Low (Stop Condition Setup)			100	ns (min)
$t_{SU,STA}$	SMBus Repeated Start-Condition Setup Time, SMBCLK High to SMBDAT Low			0.6	μs (min)
t_{BUF}	SMBus Free Time Between Stop and Start Conditions			1.3	μs (min)

- (1) Typical figures are at $T_A = 25^\circ\text{C}$ and represent most likely parametric norms at the time of product characterization. The typical specifications are not guaranteed.
- (2) Limits are guaranteed to TI's AOQL (Average Outgoing Quality Level).
- (3) The output rise time is measured from $(V_{IN(0)max} - 0.15\text{V})$ to $(V_{IN(1)min} + 0.15\text{V})$.
- (4) The output fall time is measured from $(V_{IN(1)min} + 0.15\text{V})$ to $(V_{IN(0)max} - 0.15\text{V})$.
- (5) Holding the SMBDAT and/or SMBCLK lines Low for a time interval greater than $t_{TIMEOUT}$ will reset the LM95245's SMBus state machine, therefore setting SMBDAT and SMBCLK pins to a high impedance state.

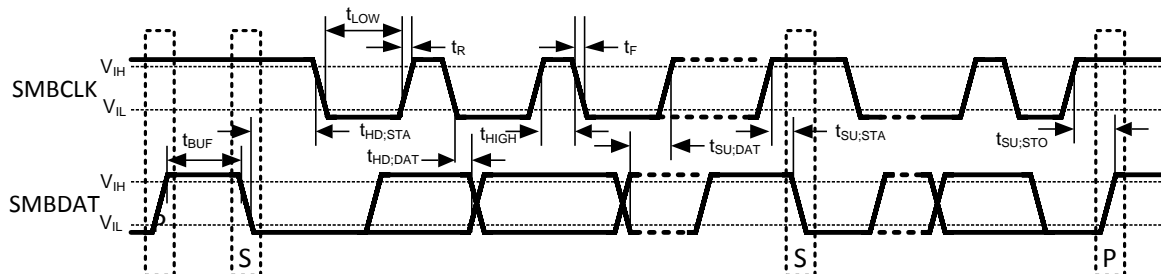

Figure 2. SMBus Communication

Typical Performance Characteristics

Thermal Diode Capacitor or PCB Leakage Current Effect Remote Diode Temperature Reading

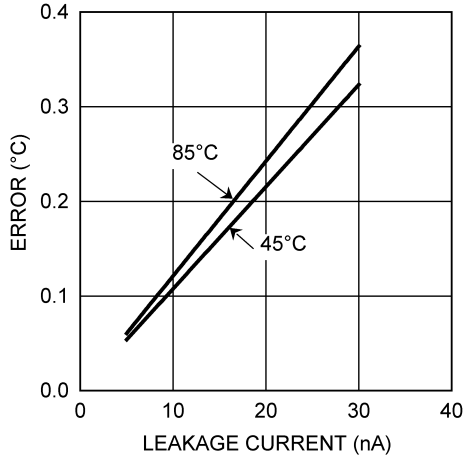

Figure 3.

Remote Temperature Reading Sensitivity to Thermal Diode Filter Capacitance, TruTherm Enabled

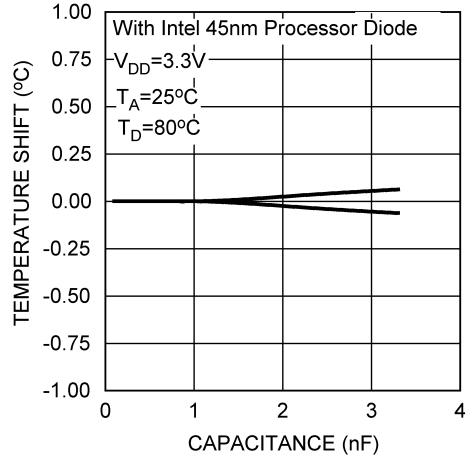

Figure 4.

Conversion Rate Effect on Average Power Supply Current

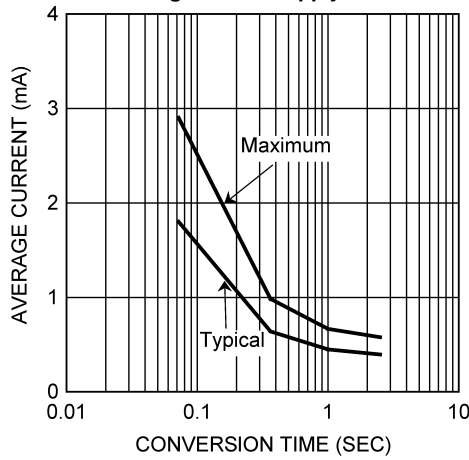

Figure 5.

Intel Processor on 45nm, 65nm, or 90 nm Process Thermal Diode Performance Comparison

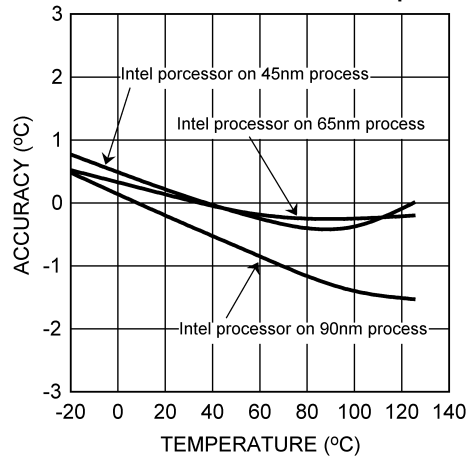

Figure 6.

FUNCTIONAL DESCRIPTION

The LM95245 is a temperature sensor that measures Local and Remote temperature zones. The LM95245 uses a ΔV_{be} temperature sensing method. A differential voltage, representing temperature, is digitized using a Sigma-Delta analog to digital converter. TruTherm BJT (Transistor) Beta Compensation Technology allows the LM95245 to accurately sense the temperature of a thermal diode found on die fabricated using a sub-micron process. For more information on TruTherm Technology see [Applications Hints](#). The LM95245 is compatible with the serial SMBus version 2.0 two-wire serial interface.

The LM95245 has \overline{OS} and \overline{TCRIT} open-drain digital outputs that indicate the state of the local and remote temperature readings when compared to user-programmable limits. If enabled, the local temperature is compared to the user-programmable Local Shared OS and TCRIT Limit Register (Default Value = 85°C). The comparison result can trigger the $\overline{T_CRIT}$ pin and/or the \overline{OS} pin depending on the settings of the Local TCRIT Mask and OS Mask bits found in Configuration Register 1. The comparison result can also be read back from Status Register 1. If enabled, the remote temperature is compared to the user-programmable Remote TCRIT Limit Register (Default Value = 110°C), and the Remote OS Limit Register (Default Value = 85°C) values. The comparison result can trigger the $\overline{T_CRIT}$ pin and/or the \overline{OS} pin depending on the settings of Configuration Register 1. The following table describes the default temperature settings for each measured temperature that triggers $\overline{T_CRIT}$ and/or \overline{OS} pins:

Output Pin	Remote, °C	Local, °C
$\overline{T_CRIT}$	110	85
\overline{OS}	85	85

The following table describes the limit register mapping to the $\overline{T_CRIT}$ and/or \overline{OS} pins:

Output Pin	Remote	Local
$\overline{T_CRIT}$	Remote TCRIT Limit	Local Shared OS/TCRIT Limit
\overline{OS}	Remote OS Limit	Local Shared OS/TCRIT Limit

The $\overline{T_CRIT}$ and \overline{OS} outputs are open-drain, active low.

The remote temperature readings support a programmable digital filter. Based on the settings in Configuration Register 2 a digital filter can be turned on to improve the noise performance of the remote temperature as well as to increase the resolution of the temperature reading. If the filter is enabled the filtered readings are used for TCRIT and OS comparisons. The LM95245 may be placed in low power consumption (Standby) mode by setting the STOP/RUN bit found in Configuration Register 1. In the Standby mode, the LM95245's SMBus interface remains active while all circuitry not required is turned off. In the Standby mode the host can trigger one round of conversions by writing to the One-Shot Register. The value written into this register is not kept. Local and Remote temperatures will be converted once and the $\overline{T_CRIT}$ and \overline{OS} pins will reflect the comparison results based on this set of conversions results.

All the temperature readings are in 16-bit left-justified word format. The 10-bit plus sign local temperature reading is contained in two 8-bit registers: Local Temp MSB and Local Temp LSB Registers. The remote temperature supports both a 13-bit unsigned and a 12-bit plus sign format. These readings are available in their corresponding registers as described in [Table 8](#). The lower 2-bits of the remote temperature reading will contain temperature information only if the digital filter is enabled. If the digital filter is disabled, these two bits will read back 0.

The signed and unsigned remote temperature readings are available simultaneously in separate registers, therefore allowing both negative temperatures and temperatures 128°C and above to be measured.

All Limit Registers support unsigned temperature format with 1°C LSb resolution. The Local Shared TCRIT and OS Limit Register is 7 bits for limits between 0°C and 127°C. The Remote Temperature TCRIT and OS Limit Registers are 8 bits each for limits between 0°C and 255°C.

CONVERSION SEQUENCE

In the power-up default state the LM95245 takes a maximum of 1 second to convert the Local Temperature, Remote Temperature, and to update all of its registers. Only during the conversion process is the Busy bit (D7) in Status Register 1 (02h) high. These conversions are addressed in a round-robin sequence. The conversion rate may be modified by the Conversion Rate bits found in the Conversion Rate Register (R/W: 04h/0Ah). When the conversion rate is modified a delay is inserted between conversions, the actual maximum conversion time remains at 72 ms. Different conversion rates will cause the LM95245 to draw different amounts of supply current as shown in Figure 7.

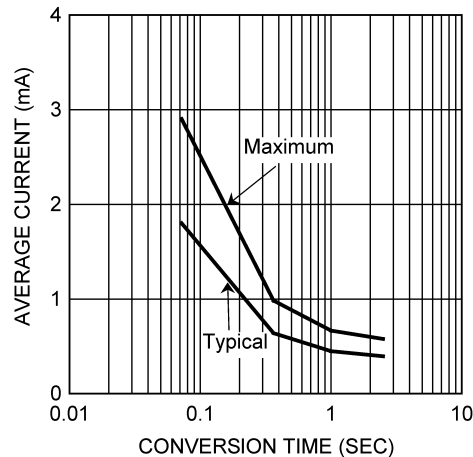

Figure 7. Conversion Rate Effect on Power Supply Current

POWER-ON-DEFAULT STATES

LM95245 always powers up to these known default states. The LM95245 remains in these states until after the first conversion.

1. Command Register set to 00h
2. Conversion Rate register defaults to 02h (1 second).
3. Local Temperature set to 0°C until the end of the first conversion
4. Remote Diode Temperature set to 0°C until the end of the first conversion
5. Remote OS limit default is 55h (85 °C).
6. Local Shared and TCRIT limit default is 55h (85 °C).
7. Remote TCRIT limit default is 6Eh (110 °C).
8. Remote Offset High and Low bytes default to 00h.
9. Configuration Register 1 defaults to 00h. This sets the LM95245 as follows:
 - (a) The STOP/ $\overline{\text{RUN}}$ defaults to the active/converting mode.
 - (b) The Local and Remote TCRIT and OS Masks are reset to 0.
10. Configuration Register 2 defaults to 1Fh. This sets the LM95245 as follows:
 - (a) Remote Diode digital filter defaults on.
 - (b) The Remote Diode mode defaults to a typical Intel processor on 45/65/90 nm process.
 - (c) Diode Fault Mask bit for TCRIT defaults to 1.
 - (d) Diode Fault Mask bit for OS defaults to 0.
 - (e) Pin 6 Function defaults to Address Input function (A0).

SMBus INTERFACE

The LM95245 operates as a slave on the SMBus, so the SMBCLK line is an input and the SMBDAT line is bidirectional. The LM95245 never drives the SMBCLK line and it does not support clock stretching. According to SMBus specifications, the LM95245 has a 7-bit slave address. Three SMBus addresses can be selected by connecting pin 6 (A0) to either Low, Mid-Supply or High voltages. The address selection table below shows two sets of possible selections for the LM95245C1MM and the LM95245C1MM-1.

State of the A0 Pin	LM95245C1MM SMBus Device Address		LM95245C1MM-1 SMBus Device Address	
	HEX	Binary	HEX	Binary
Low	18	001 1000	19	001 1001
Mid-Supply	29	010 1001	29	010 1001
High	4C	100 1100	4D	100 1100

The $\overline{OS}/A0$ pin, after power-up, defaults as an address select input pin (A0). After power-up, the $\overline{OS}/A0$ pin can only be programmed as an OS output when it is in the “High” state. Therefore, 4Ch is the only valid slave address that can be used when the $\overline{OS}/A0$ pin is programmed to function as an OS output. When the $\overline{OS}/A0$ pin is programmed to function as an A0 input the LM95245 will immediately detect the state of this pin to determine its SMBus slave address. The LM95245 does not latch the state of the A0 pin when it is functioning as an input. If the $\overline{OS}/A0$ pin is not used it must be externally connected through hardware to some state, as shown in the table, in order to guarantee that the proper address is selected and not in an indeterminate state. The $\overline{OS}/A0$ does not have an internal pull-up.

DIGITAL FILTER

In order to suppress erroneous remote temperature readings due to noise, the LM95245 incorporates a digital filter for the Remote Temperature Channel. The filter is accessed in the Configuration Register 2, bits D2 (FE1) and D1 (FE0). The filter can be set according to the following table.

FE1	FE0	Filter Setting
0	0	Filter Off
0	1	Reserved
1	0	Reserved
1	1	Filter On

[Filter Impulse and Step Response Curves](#) depicts the filter output in response to a step input and an impulse input.

Filter Impulse and Step Response Curves

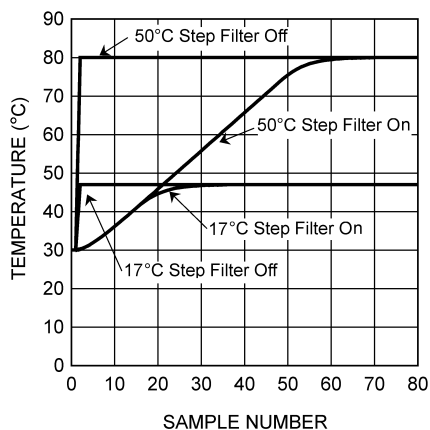

Figure 8. Seventeen and Fifty Degree Step Response

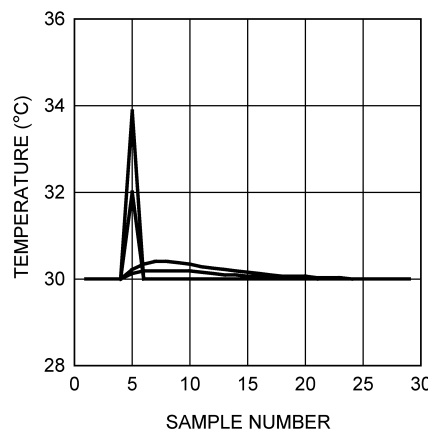

Figure 9. Impulse Response with Input Transients Less Than 4°C

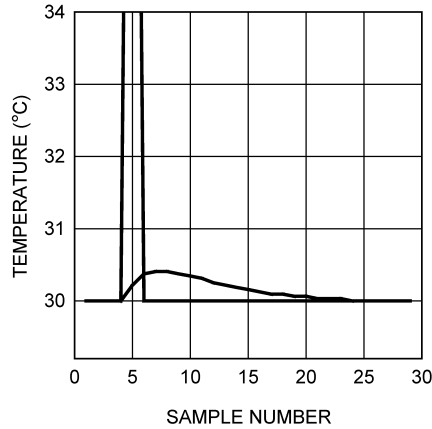

Figure 10. Impulse Response with Input Transients Greater Than 4°C

Figure 11 shows the filter in use in a typical Intel processor on a 45/65/90 nm process system. Note that the two curves have been purposely offset for clarity. Inserting the filter does not induce an offset as shown.

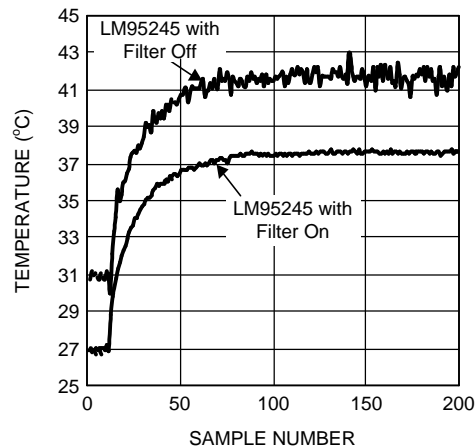

Figure 11. Digital Filter Response in a Typical Intel Processor on a 45nm, 65 nm or 90 nm Process (Filter Curves Were Purposely Offset for Clarity)

TEMPERATURE DATA FORMAT

Temperature data can only be read from the Local and Remote Temperature registers.

Remote temperature data with the digital filter off is represented by an 10-bit plus sign, two's complement word and 11-bit unsigned binary word with an LSb (Least Significant Bit) equal to 0.125°C. The data format is a left justified 16-bit word available in two 8-bit registers. Unused bits report "0".

Remote temperature data with the digital filter on is represented by a 12-bit plus sign, two's complement word and 13-bit unsigned binary word with an LSb (Least Significant Bit) equal to 0.03125°C (1/32°C). The data format is a left justified 16-bit word available in two 8-bit registers. Unused bits report "0".

Table 3. 11-Bit, 2's Complement (10-Bit Plus Sign)

Temperature	Digital Output	
	Binary	Hex
+125°C	0111 1101 0000 0000	7D00h
+25°C	0001 1001 0000 0000	1900h
+1°C	0000 0001 0000 0000	0100h
+0.125°C	0000 0000 0010 0000	0020h
0°C	0000 0000 0000 0000	0000h

Table 3. 11-Bit, 2's Complement (10-Bit Plus Sign) (continued)

Temperature	Digital Output	
	Binary	Hex
-0.125°C	1111 1111 1110 0000	FFE0h
-1°C	1111 1111 0000 0000	FF00h
-25°C	1110 0111 0000 0000	E700h
-55°C	1100 1001 0000 0000	C900h

Table 4. 11-Bit, Unsigned Binary

Temperature	Digital Output	
	Binary	Hex
+255.875°C	1111 1111 1110 0000	FFE0h
+255°C	1111 1111 0000 0000	FF00h
+201°C	1100 1001 0000 0000	C900h
+125°C	0111 1101 0000 0000	7D00h
+25°C	0001 1001 0000 0000	1900h
+1°C	0000 0001 0000 0000	0100h
+0.125°C	0000 0000 0010 0000	0020h
0°C	0000 0000 0000 0000	0000h

Table 5. 13-Bit, 2's Complement (12-Bit Plus Sign)

Temperature	Digital Output	
	Binary	Hex
+125°C	0111 1101 0000 0000	7D00h
+25°C	0001 1001 0000 0000	1900h
+1°C	0000 0001 0000 0000	0100h
+0.03125°C	0000 0000 0000 1000	0008h
0°C	0000 0000 0000 0000	0000h
-0.03125°C	1111 1111 1111 1000	FFF8h
-1°C	1111 1111 0000 0000	FF00h
-25°C	1110 0111 0000 0000	E700h
-55°C	1100 1001 0000 0000	C900h

Table 6. 13-Bit, Unsigned Binary

Temperature	Digital Output	
	Binary	Hex
+255.875°C	1111 1111 1110 0000	FFE0h
+255°C	1111 1111 0000 0000	FF00h
+201°C	1100 1001 0000 0000	C900h
+125°C	0111 1101 0000 0000	7D00h
+25°C	0001 1001 0000 0000	1900h
+1°C	0000 0001 0000 0000	0100h
+0.03125°C	0000 0000 0000 1000	0008h
0°C	0000 0000 0000 0000	0000h

Local Temperature data is represented by a 10-bit plus sign, two's complement word with an LSb (Least Significant Bit) equal to 0.125°C. The data format is a left justified 16-bit word available in two 8-bit registers. Unused bits will always report "0". Local temperature readings greater than +127.875°C are clamped to +127.875°C, they will not roll-over to negative temperature readings.

Table 7. 11-Bit, 2's Complement (10-Bit Plus Sign)

Temperature	Digital Output	
	Binary	Hex
+125°C	0111 1101 0000 0000	7D00h
+25°C	0001 1001 0000 0000	1900h
+1°C	0000 0001 0000 0000	0100h
+0.125°C	0000 0000 0010 0000	0020h
0°C	0000 0000 0000 0000	0000h
-0.125°C	1111 1111 1110 0000	FFE0h
-1°C	1111 1111 0000 0000	FF00h
-25°C	1110 0111 0000 0000	E700h
-55°C	1100 1001 0000 0000	C900h

SMBDAT OPEN-DRAIN OUTPUT

The SMBDAT output is an open-drain output and does not have internal pull-ups. A “high” level will not be observed on this pin until pull-up current is provided by some external source, typically a pull-up resistor. Choice of resistor value depends on many system factors but, in general, the pull-up resistor should be as large as possible without effecting the SMBus desired data rate. This will minimize any internal temperature reading errors due to internal heating of the LM95245. The maximum resistance of the pull-up to provide a 2.1V high level, based on LM95245 specification for High Level Output Current with the supply voltage at 3.0V, is 82 kΩ (5%) or 88.7 kΩ (1%).

T_CRIT OUTPUT AND TCRIT LIMIT

The LM95245's $\overline{T_CRIT}$ pin is an active-low open-drain output that is triggered when the local and/or the remote temperature conversion is above the limits defined by the Remote and/or Local Limit registers. The state of the $\overline{T_CRIT}$ pin will return to the HIGH state when both the Local and Remote temperatures are below the values programmed into the Limit Registers less the value in the Common Hysteresis Register. Additionally, if the remote temperature exceeds the value in the Remote TCRIT Limit Register the Status Bit for Remote TCRIT (RTCRIT), in Status Register 1, is set to 1. In the same way if the local temperature exceeds the value in the Local Shared OS and TCRIT Limit Register the Status Bit for the Shared Local OS and TCRIT (LOC) bit in Status Register 1 is set to 1. The $\overline{T_CRIT}$ output and the Status Register flags are updated after every Local and Remote temperature conversion. See [Figure 12](#)

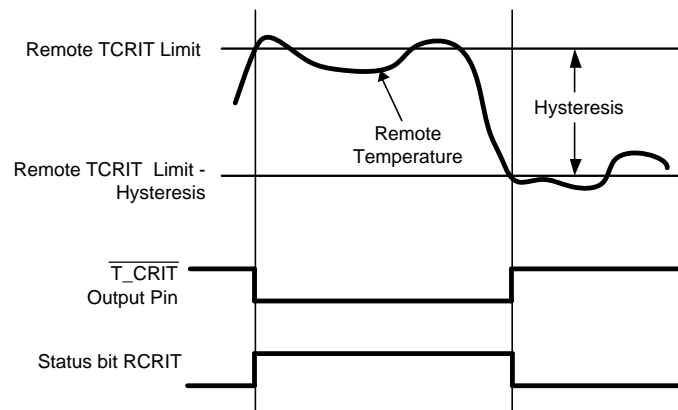
**Figure 12. $\overline{T_CRIT}$ Comparator Temperature Response Diagram**

OS OUTPUT AND OS LIMIT

The LM95245's OS/A0 pin is selected as an OS digital output as described in [SMBus INTERFACE](#). As an OS pin, it is activated whenever the local and/or remote temperature conversion is above the limits defined by the Limit registers. If the remote temperature exceeds the value in the Remote OS Limit Register the Status Bit for Remote OS (ROS) in Status Register 1 is set to 1. In the same way if the local temperature exceeds the value in the Local Shared OS and TCRIT Limit Register the Status Bit for the Shared Local OS and TCRIT (LOC) bit in Status Register 1 is set to 1. The state of the T_CRIT pin output will return to the HIGH state when both the Local and Remote temperatures are below the values programmed into the Limit Registers less the value in the Common Hysteresis Register. The OS output and the Status Register flags are updated after every Local and Remote temperature conversion. See [Figure 13](#).

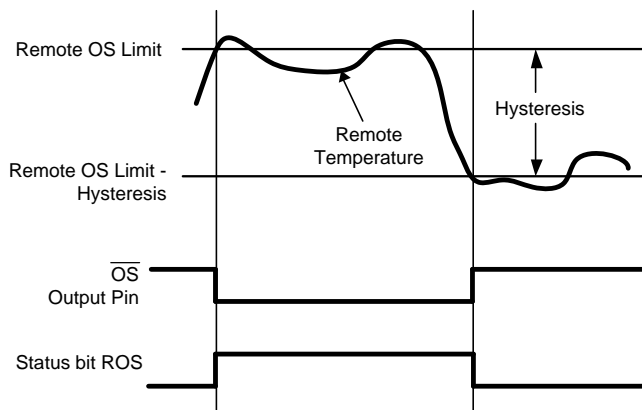

Figure 13. OS Temperature Response Diagram

DIODE FAULT DETECTION

The LM95245 is equipped with operational circuitry designed to detect fault conditions concerning the remote diodes. In the event that the D+ pin is detected as shorted to GND, V_{DD} or D+ is floating, the Remote Temperature reading is -128.000 °C if signed format is selected and +255.875 °C if unsigned format is selected. In addition, the Status Register 1 bit D2 is set.

COMMUNICATING with the LM95245

SMBus Timing Diagrams for Access of Data (Default Address of 4Ch is Shown)

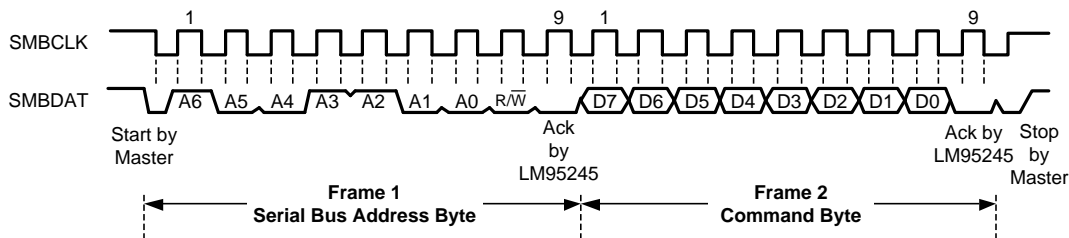

Figure 14. (a) Serial Bus Write to the Internal Command Register

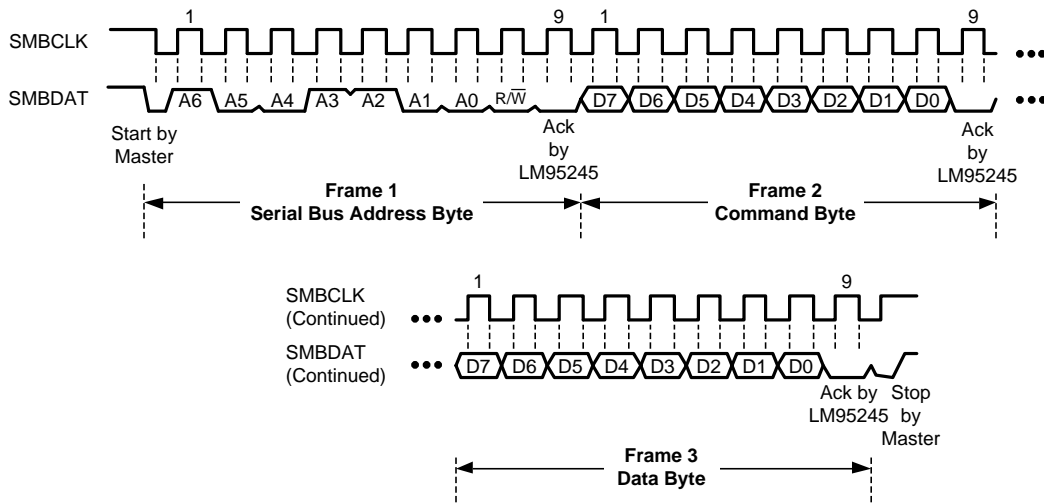

Figure 15. (b) Serial Bus Write to the Internal Command Register Followed by a Data Byte

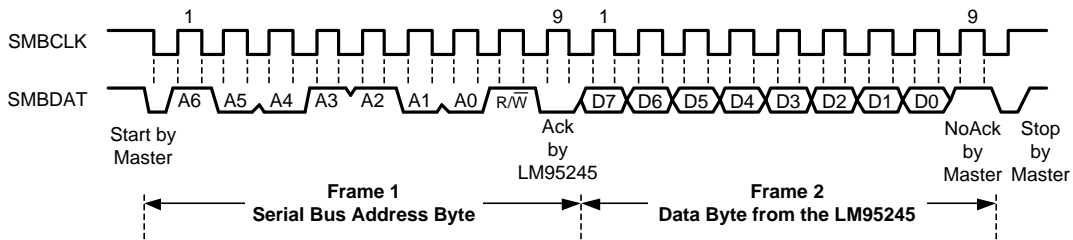

Figure 16. (c) Serial Bus byte Read from a Register with the Internal Command Register Preset to Desired Value

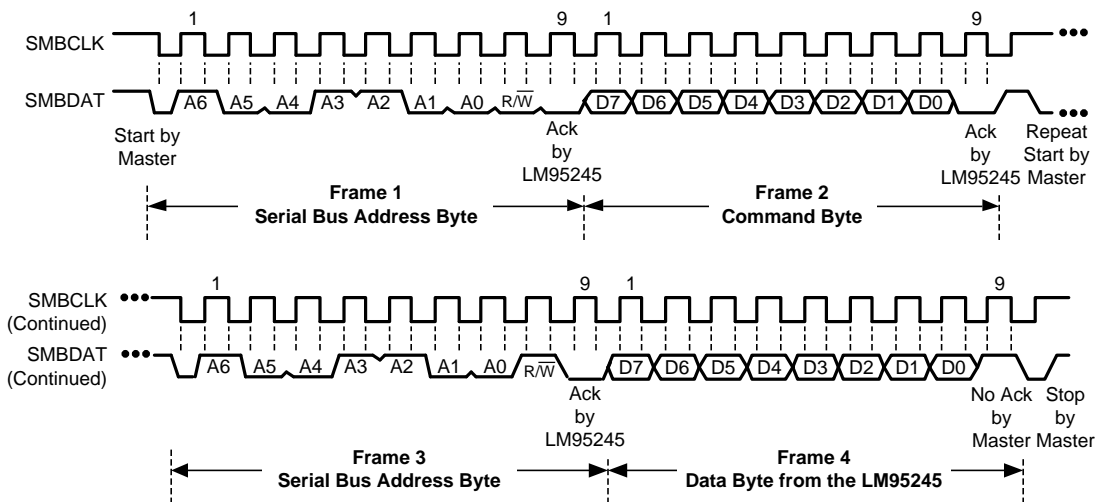

Figure 17. (d) Serial Bus Write followed by a Repeat Start and Immediate Read

The data registers in the LM95245 are selected by the Command Register. At power-up the Command Register is set to "00", the location for the Read Local Temperature Register. The Command Register latches the last location it was set to. Each data register in the LM95245 falls into one of four types of user accessibility:

1. Read only
2. Write only

3. Write/Read same address
4. Write/Read different address

A **Write** to the LM95245 will always include the address byte and the command byte. A write to any register requires one data byte.

Reading the LM95245 can take place either of two ways:

1. If the location latched in the Command Register is correct (most of the time it is expected that the Command Register will point to one of the Read Temperature Registers because that will be the data most frequently read from the LM95245), then the read can simply consist of an address byte, followed by retrieving the data byte.
2. If the Command Register needs to be set, then an address byte, command byte, repeat start, and another address byte will accomplish a read.

The data byte has the most significant bit first. At the end of a read, the LM95245 can accept either acknowledge or No Acknowledge from the Master (No Acknowledge is typically used as a signal for the slave that the Master has read its last byte). When retrieving all 11 bits from a previous remote diode temperature measurement, the master must insure that all 11 bits are from the same temperature conversion. This may be achieved by reading the MSB register first. The LSB will be locked after the MSB is read. The LSB will be unlocked after being read. If the user reads MSBs consecutively, each time the MSB is read, the LSB associated with that temperature will be locked in and override the previous LSB value locked-in.

SERIAL INTERFACE RESET

In the event that the SMBus Master is RESET while the LM95245 is transmitting on the SMBDAT line, the LM95245 must be returned to a known state in the communication protocol. This may be done in one of two ways:

1. When SMBDAT is LOW, the LM95245 SMBus state machine resets to the SMBus idle state if either SMBDAT or SMBCLK are held low for more than 35 ms (t_{TIMEOUT}). Note that according to SMBus specification 2.0 all devices are to timeout when either the SMBCLK or SMBDAT lines are held low for 25 - 35 ms. Therefore, to insure a timeout of all devices on the bus the SMBCLK or SMBDAT lines must be held low for at least 35 ms.
2. When SMBDAT is HIGH, have the master initiate an SMBus start. The LM95245 will respond properly to an SMBus start condition at any point during the communication. After the start the LM95245 will expect an SMBus Address address byte.

ONE-SHOT CONVERSION

The One-Shot register is used to initiate a single conversion and comparison cycle when the device is in standby mode, after which the device returns to standby. This is not a data register and it is the write operation that causes the one-shot conversion. The data written to this address is irrelevant and is not stored. A zero will always be read from this register.

LM95245 REGISTERS

Command register selects which registers will be read from or written to. Data for this register should be transmitted during the Command Byte of the SMBus write communication. POR means Power-On Reset.

P0-P7: Command

P7	P6	P5	P4	P3	P2	P1	P0
Command							

Table 8. Register Summary

Register Name	Read Address (Hex)	Write Address (Hex)	No. of bits	POR Default (Hex)	Read/Write	Description
TEMPERATURE SIGNED VALUE REGISTERS						
Local Temp MSB	0x00	NA	8	–	RO	Supports SMBus byte
Local Temp LSB	0x30	NA	3	–	RO	All unused bits are reported as "0".
Remote Temp MSB – Signed	0x01	NA	8	–	RO	Supports SMBus byte
Remote Temp LSB – Signed	0x10	NA	5/3	–	RO	All unused bits are reported as "0".
TEMPERATURE UNSIGNED VALUE REGISTERS						
Remote Temp MSB – Unsigned	0x31	NA	8	–	RO	Supports SMBus byte reads
Remote Temp LSB – Unsigned	0x32	NA	5/3	–	RO	All unused bits are reported as "0".
DIODE CONFIGURATION REGISTERS						
Configuration Register 2	0xBF	0xBF	5	0x1F	R/W	Filter Enable, Diode Model Select, Diode Fault Mask; Pin 6 $\overline{OS}/A0$ function select
Remote Offset High Byte	0x11	0x11	8	0x00	R/W	2's Complement
Remote Offset Low Byte	0x12	0x12	3	0x00	R/W	2's Complement All unused bits are reported as "0".
GENERAL CONFIGURATION REGISTERS						
Configuration Register 1	0x03/ 0x09	0x09/ 0x03	5	0x00	R/W	STOP/ \overline{RUN} , Remote TCRT mask, Remote OS mask, Local TCRT mask, Local OS mask
Conversion Rate	0x04/0x0A	0x04/0x0A	2	0x02	R/W	Continuous or specific settings
One-Shot	NA	0x0F	–	–	WO	A write to this register activates one conversion if STOP/ \overline{RUN} bit = 1.
STATUS REGISTERS						
Status Register 1	0x02	NA	5	–	RO	Busy bit, and status bits
Status Register 2	0x33	NA	2	–	RO	Not Ready bit
LIMIT REGISTERS						
Remote OS Limit	0x07/ 0x0D	0x0D/ 0x07	8	0x55	R/W	Unsigned 0 to 255 °C Default 85 °C
Local Shared OS and T_Crit Limit	0x20	0x20	7	0x55	R/W	Unsigned 0 to 127 °C Default 85 °C
Remote T_Crit Limit	0x19	0x19	8	0x6E	R/W	Unsigned 0 to 255 °C Default 110 °C
Common Hysteresis	0x21	0x21	5	0x0A	R/W	up to 31°C
IDENTIFICATION REGISTERS						
Manufacturer ID	0xFE			0x01	RO	Always returns 0x01
Revision ID	0xFF			0xB3	RO	Returns revision number.

LOCAL and REMOTE MSB and LSB TEMPERATURE REGISTERS
Table 9. Local Temperature MSB

(Read Only Address 00h)

10-bit plus sign format:

BIT	D7	D6	D5	D4	D3	D2	D1	D0
Value	SIGN	64	32	16	8	4	2	1

Temperature Data: LSb = 1°C.

Table 10. Local Temperature LSB

(Read Only Address 30h)

10-bit plus sign format:

BIT	D7	D6	D5	D4	D3	D2	D1	D0
Value	0.5	0.25	0.125	0	0	0	0	0

Temperature Data: LSb = 0.125°C.

Table 11. Signed Remote Temperature MSB

(Read Only Address 01h)

12-bit plus sign format:

BIT	D7	D6	D5	D4	D3	D2	D1	D0
Value	SIGN	64	32	16	8	4	2	1

Temperature Data: LSb = 1°C.

Table 12. Signed Remote Temperature LSB, Filter On

(Read Only Address 10h)

12-bit plus sign binary formats with filter on:

BIT	D7	D6	D5	D4	D3	D2	D1	D0
Value	0.5	0.25	0.125	0.0625	0.03125	0	0	0

Table 13. Signed Remote Temperature LSB, Filter Off

(Read Only Address 10h)

12-bit plus sign binary formats with filter off:

BIT	D7	D6	D5	D4	D3	D2	D1	D0
Value	0.5	0.25	0.125	0	0	0	0	0

Temperature Data: LSb = 0.125°C filter off or 0.03125°C filter on.

Table 14. Unsigned Remote Temperature MSB

(Read Only Address 31h)

13-bit unsigned format:

BIT	D7	D6	D5	D4	D3	D2	D1	D0
Value	128	64	32	16	8	4	2	1

Temperature Data: LSb = 1°C.

Table 15. Unsigned Remote Temperature LSB, Filter On

(Read Only Address 32h)

13-bit unsigned binary formats with filter on:

BIT	D7	D6	D5	D4	D3	D2	D1	D0
Value	0.5	0.25	0.125	0.0625	0.03125	0	0	0

Table 16. Unsigned Remote Temperature LSB, Filter Off

(Read Only Address 32h)

13-bit unsigned binary formats with filter off:

BIT	D7	D6	D5	D4	D3	D2	D1	D0
Value	0.5	0.25	0.125	0	0	0	0	0

Temperature Data: LSb = 0.125°C filter off or 0.03125°C filter on.

For data synchronization purposes, the MSB register should be read first if the user wants to read both MSB and LSB registers. The LSB will be locked after the MSB is read. The LSB will be unlocked after being read. If the user reads MSBs consecutively, each time the MSB is read, the LSB associated with that temperature will be locked in and override the previous LSB value locked-in.

DIODE CONFIGURATION REGISTERS**Table 17. Configuration Register 2**

(Read/write Address BFh):

D7	D6	D5	D4	D3	D2	D1	D0
0	$\overline{\text{OS}}$ /A0 Function Select	OS Fault Mask	$\overline{\text{T_CRIT}}$ Mask	TruTherm Select	RFE1	RFE0	1

Bits	Name	Description
7	Reserved	Reports "0" when read.
6	$\overline{\text{OS}}$ /A0 Function Select	0: Address (A0) function is enabled 1: Over-temperature Shutdown (OS) is enabled
5	Diode Fault Mask for $\overline{\text{OS}}$	0: Off 1: On
4	Diode Fault Mask for $\overline{\text{T_CRIT}}$	0: Off 1: On
3	Remote Diode TruTherm Mode Select	0: Selects Diode Model 2, MMBT3904, with TruTherm technology disabled. Note, performance in this mode is not guaranteed. 1: Selects Diode Model 1, A typical Intel Processor, with 45nm, 65 nm or 90 nm technology, and TruTherm technology enabled.
2-1	Remote Filter Enable	00: Filter Disable 01: Reserved 10: Reserved 11: Filter Enable
0	Reserved	Reports "1" when read.

Power up default is 1Fh.

Table 18. Remote Offset High Byte (2's Complement)

(R/W Address 11h)

10-bit plus sign format:

BIT	D7	D6	D5	D4	D3	D2	D1	D0
Value	SIGN	64	32	16	8	4	2	1

Power up default is 00h.

Table 19. Remote Offset Low Byte (2's Complement)

(R/W Address 12h)

10-bit plus sign format:

BIT	D7	D6	D5	D4	D3	D2	D1	D0
Value	0.50	0.25	0.125	0	0	0	0	0

Power up default is 00h. LSb = 0.125 °C.

GENERAL CONFIGURATION REGISTERS
Table 20. Configuration Register 1

(Read/write Address 03h/09h or 09h/03h):

D7	D6	D5	D4	D3	D2	D1	D0
0	STOP/RUN	0	Remote $\overline{T_CRIT}$ Mask	Remote \overline{OS} Mask	Local $\overline{T_CRIT}$ Mask	Local \overline{OS} Mask	0

Bits	Name	Description
7	Reserved	Reports "0" when read.
6	STOP/ \overline{RUN}	0: Active / Converting 1: Standby
5	Reserved	Reports "0" when read.
4	Remote $\overline{T_CRIT}$ Mask	0: Off 1: On
3	Remote \overline{OS} Mask	0: Off 1: On
2	Local $\overline{T_CRIT}$ Mask	0: Off 1: On
1	Local \overline{OS} Mask	0: Off 1: On
0	Reserved	Reports "0" when read.

Power up default is 00h.

Table 21. Conversion Rate Register

(Read/write Address 04h/0Ah or 0Ah/04h):

2-bit format:

BIT	D7	D6	D5	D4	D3	D2	D1	D0
Value	0	0	0	0	0	0	MSb	LSb

Bits	Name	Description
7:2	Reserved	Reports "0" when read.
1:0	Conversion Rate	00: Continuous (33 ms typical when remote diode is missing or fault or 63 ms typical with remote diode connected) 01: 0.364 seconds 10: 1 second 11: 2.5 seconds

Power up default is 02h (1 second).

Table 22. One Shot Register

(Write Only Address 0Fh):

Writing to this register will start one conversion if the device is in standby mode (i.e. STOP/ \overline{RUN} bit = 1).
--

STATUS REGISTERS

Table 23. Status Register 1

(Read Only Address 02h):

D7	D6	D5	D4	D3	D2	D1	D0
Busy	0	0	ROS	0	Diode Fault	RTCRT	LOC

Bits	Name	Description
7	Busy	When set to "1" the part is converting.
6-5	Reserved	Report "0" when read.
4	ROS	Status Bit for Remote OS
3	Reserved	Reports "0" when read.
2	Diode Fault	Status bit for missing diode (Either D+ is shorted to GND, or V _{DD} ; or D+ is floating.) Note: The unsigned registers will report 0°C if read; the signed value registers will report -128.000°C.
1	RTCRT	Status bit for Remote TCRIT.
0	LOC	Status bit for the shared Local OS and TCRIT .

Table 24. Status Register 2

(Read Only Address 33h):

D7	D6	D5	D4	D3	D2	D1	D0
Not Ready	Reserved	0	0	0	0	0	0

Bits	Name	Description
7	Not Ready	Waiting for 30 ms power-up sequence to end.
6	Reserved	Can report "0" or "1" when read.
5-0	Reserved	Reports "0" when read.

LIMIT REGISTERS

Table 25. Unsigned Remote OS Limit - 0°C to 255°C

(Read/Write Address 07h/0Dh or 0Dh/07h):

D7	D6	D5	D4	D3	D2	D1	D0
128	64	32	16	8	4	2	1

Power on Reset default is 55h (85°C).

Table 26. Unsigned Local Shared OS and T_CRIT Limit - 0°C to 127°C

(Read/Write Address 20h):

D7	D6	D5	D4	D3	D2	D1	D0
128	64	32	16	8	4	2	1

Power on Reset default is 55h (85°C).

Table 27. Unsigned Remote T_CRIT Limit - 0°C to 255°C

(Read/Write Address 19h):

D7	D6	D5	D4	D3	D2	D1	D0
128	64	32	16	8	4	2	1

Power on Reset default is 6Eh (110°C).

Table 28. Common Hysteresis Register

(Read/Write Address 21h):

D7	D6	D5	D4	D3	D2	D1	D0
0	0	0	16	8	4	2	1

Power on Reset default is 0Ah (10°C).

IDENTIFICATION REGISTERS
Table 29. Manufacturers ID Register

(Read Only Address FEh):

Always returns 01h.

D7	D6	D5	D4	D3	D2	D1	D0
0	0	0	0	0	0	0	1

Table 30. Revision ID Register

(Read Only Address FFh)

Default is B3h. This register will increment by 1 every time there is a revision to the die by Texas Instruments. The initial revision bits for B3h are shown below.

D7	D6	D5	D4	D3	D2	D1	D0
1	0	1	1	0	0	1	1

APPLICATIONS HINTS

The LM95245 can be applied easily in the same way as other integrated-circuit temperature sensors, and its remote diode sensing capability allows it to be used in new ways as well. It can be soldered to a printed circuit board, and because the path of best thermal conductivity is between the die and the pins, its temperature will effectively be that of the printed circuit board lands and traces soldered to the LM95245's pins. This presumes that the ambient air temperature is almost the same as the surface temperature of the printed circuit board; if the air temperature is much higher or lower than the surface temperature, the actual temperature of the LM95245 die will be at an intermediate temperature between the surface and air temperatures. Again, the primary thermal conduction path is through the leads, so the circuit board temperature will contribute to the die temperature much more strongly than will the air temperature.

To measure temperature external to the LM95245's die, use a remote diode. This diode can be located on the die of a target IC, allowing measurement of the IC's temperature, independent of the LM95245's temperature. A discrete diode can also be used to sense the temperature of external objects or ambient air. Remember that a discrete diode's temperature will be affected, and often dominated, by the temperature of its leads. Most silicon diodes do not lend themselves well to this application. It is recommended that an MMBT3904 transistor base-emitter junction be used with the collector tied to the base. Accuracy using the MMBT3904 is not guaranteed. For applications requiring the use of the MMBT3904 use the LM95235.

The LM95245's BJT Beta Compensation TruTherm technology allows accurate sensing of integrated thermal diodes, such as those found on most processors.

The LM95245 has been optimized to measure the remote thermal diode integrated in a typical Intel processor on 45 nm, 65 nm or 90 nm process. Using the Remote Diode Model Select register the remote inputs must be assigned to sense a typical Intel processor on 45nm, 65 nm or 90 nm process. The typical performance of the LM95245 with these processors is shown in Figure 18. The Remote Offset register can be used to compensate for temperature errors further.

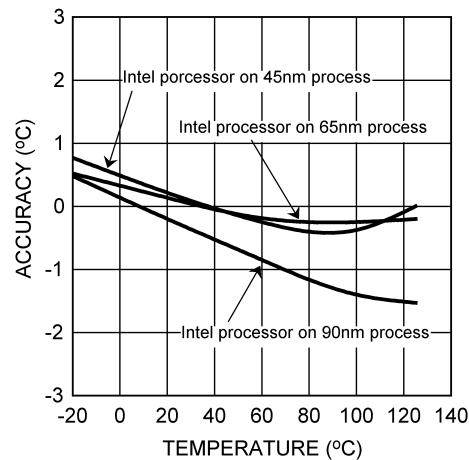

Figure 18. LM95245 Typical Performance with a Variety of Intel Processors

DIODE NON-IDEALITY

Diode Non-Ideality Factor Effect on Accuracy

When a transistor is connected as a diode, the following relationship holds for variables V_{BE} , T and I_F :

$$I_F = I_S \times \left[e^{\left(\frac{V_{BE}}{\eta \times V_t} \right)} - 1 \right]$$

where

$$V_t = \frac{kT}{q}$$

- $q = 1.6 \times 10^{-19}$ Coulombs (the electron charge),
 - T = Absolute Temperature in Kelvin
 - $k = 1.38 \times 10^{-23}$ joules/K (Boltzmann's constant),
 - η is the non-ideality factor of the process the diode is manufactured on,
 - I_S = Saturation Current and is process dependent,
 - I_f = Forward Current through the base-emitter junction
 - V_{BE} = Base-Emitter Voltage drop
- (1)

In the active region, the -1 term is negligible and may be eliminated, yielding the following equation

$$I_F = I_S \times \left[e^{\left(\frac{V_{BE}}{\eta \times V_t} \right)} \right]$$
(2)

In [Equation 2](#), η and I_S are dependant upon the process that was used in the fabrication of the particular diode. By forcing two currents with a very controlled ratio (I_{F2} / I_{F1}) and measuring the resulting voltage difference, it is possible to eliminate the I_S term. Solving for the forward voltage difference yields the relationship:

$$\Delta V_{BE} = \eta \times \left(\frac{kT}{q} \right) \times \ln \left(\frac{I_{F2}}{I_{F1}} \right)$$
(3)

Solving [Equation 3](#) for temperature yields:

$$T = \frac{q \times \Delta V_{BE}}{\eta \times k \times \ln \left(\frac{I_{F2}}{I_{F1}} \right)}$$
(4)

[Equation 4](#) holds true when a diode connected transistor such as the MMBT3904 is used. When this “diode” equation is applied to an integrated diode such as a processor transistor with its collector tied to GND as shown in [Figure 19](#) it will yield a wide non-ideality spread. This wide non-ideality spread is not due to true process variation but due to the fact that [Equation 4](#) is an approximation.

TruTherm technology uses the transistor (BJT) equation, [Equation 5](#), which is a more accurate representation of the topology of the thermal diode found in an FPGA or processor.

$$T = \frac{q \times \Delta V_{BE}}{\eta \times k \times \ln \left(\frac{I_{C2}}{I_{C1}} \right)}$$
(5)

TruTherm should only be enabled when measuring the temperature of a transistor integrated as shown in the processor of [Figure 19](#), because [Equation 5](#) only applies to this topology.

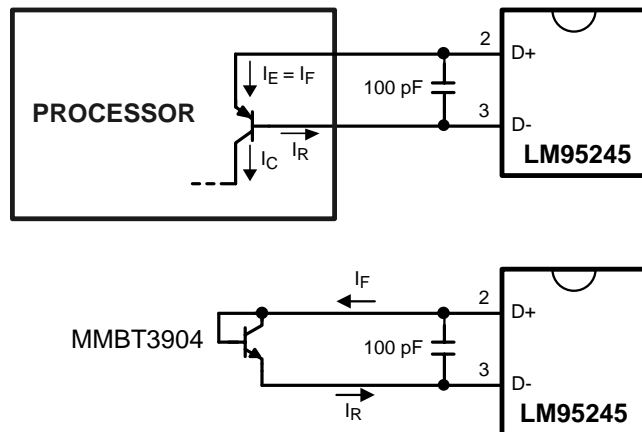

Figure 19. Thermal Diode Current Paths

Calculating Total System Accuracy

The voltage seen by the LM95245 also includes the $I_F R_S$ voltage drop of the series resistance. The non-ideality factor, η , is the only other parameter not accounted for and depends on the diode that is used for measurement. Since ΔV_{BE} is proportional to both η and T , the variations in η cannot be distinguished from variations in temperature. Since the non-ideality factor is not controlled by the temperature sensor, it will directly add to the inaccuracy of the sensor. For the Intel processor on 65nm process, Intel specifies a +4.06%/–0.897% variation in η from part to part when the processor diode is measured by a circuit that assumes diode equation, Equation 4, as true. As an example, assume a temperature sensor has an accuracy specification of $\pm 1.0^\circ\text{C}$ at a temperature of 80°C (353 Kelvin) and the processor diode has a non-ideality variation of +4.06%/–0.89%. The resulting system accuracy of the processor temperature being sensed will be:

$$T_{ACC} = + 1.0^\circ\text{C} + (+4.06\% \text{ of } 353 \text{ K}) = +15.3^\circ\text{C} \quad (6)$$

and

$$T_{ACC} = - 1.0^\circ\text{C} + (-0.89\% \text{ of } 353 \text{ K}) = -4.1^\circ\text{C} \quad (7)$$

TrueTherm technology uses the transistor equation, Equation 4, resulting in a non-ideality spread that truly reflects the process variation which is very small. The transistor equation non-ideality spread is $\pm 0.39\%$ for the 65nm thermal diode. The resulting accuracy when using TrueTherm technology improves to:

$$T_{ACC} = \pm 0.75^\circ\text{C} + (\pm 0.39\% \text{ of } 353 \text{ K}) = \pm 2.16^\circ\text{C} \quad (8)$$

Intel does not specify the diode model ideality and series resistance of the thermal diodes on 45nm so a similar comparison cannot be calculated, but lab experiments have shown similar improvement. For the 45nm processor the ideality spread as specified by Intel is -0.399% to +0.699%. The resulting spread in accuracy when using TrueTherm technology with the thermal diode on Intel processors with 45nm process is:

$$T_{ACC} = -0.75^\circ\text{C} + (-0.39\% \text{ of } 353 \text{ K}) = -2.16^\circ\text{C} \quad (9)$$

to

$$T_{ACC} = +0.75^\circ\text{C} + (+0.799\% \text{ of } 353 \text{ K}) = +4.32^\circ\text{C} \quad (10)$$

The next error term to be discussed is that due to the series resistance of the thermal diode and printed circuit board traces. The thermal diode series resistance is specified on most processor data sheets. For Intel processors in 45 nm process, this is specified at 4.5Ω typical with a minimum of 3Ω and a maximum of 7Ω . The LM95245 accommodates the typical series resistance of Intel Processor on 45 nm process. The error that is not accounted for is the spread of the processor's series resistance. The equation used to calculate the temperature error due to series resistance (T_{ER}) for the LM95245 is simply:

$$T_{ER} = \left(0.62 \frac{^\circ\text{C}}{\Omega} \right) \times R_{PCB} \quad (11)$$

Solving Equation 11 for R_{PCB} equal to -1.5Ω to 2.5Ω results in the additional error due to the spread in this series resistance of -0.93°C to $+1.55^{\circ}\text{C}$. The spread in error cannot be canceled out, as it would require measuring each individual thermal diode device. This is quite difficult and impractical in a large volume production environment.

Equation 11 can also be used to calculate the additional error caused by series resistance on the printed circuit board. Since the variation of the PCB series resistance is minimal, the bulk of the error term is always positive and can simply be cancelled out by subtracting it from the output readings of the LM95245.

Processor Family	Transistor Equation η_T , non-ideality			Series R, Ω
	min	typ	max	
Intel Processor on 45 nm process	0.997	1.001	1.008	4.5
Intel Processor on 65 nm process	0.997	1.001	1.005	4.52

Note: NA = Not Available at publication of this document.

PCB LAYOUT FOR MINIMIZING NOISE

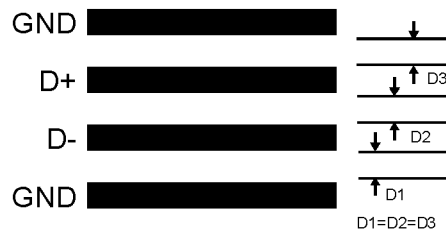

Figure 20. Ideal Diode Trace Layout

In a noisy environment, such as a processor mother board, layout considerations are very critical. Noise induced on traces running between the remote temperature diode sensor and the LM95245 can cause temperature conversion errors. Keep in mind that the signal level the LM95245 is trying to measure is in microvolts. The following guidelines should be followed:

1. V_{DD} should be bypassed with a $0.1\ \mu\text{F}$ capacitor in parallel with $100\ \text{pF}$. The $100\ \text{pF}$ capacitor should be placed as close as possible to the power supply pin. A bulk capacitance of approximately $10\ \mu\text{F}$ needs to be in the near vicinity of the LM95245.
2. A $100\ \text{pF}$ diode bypass capacitor is recommended to filter high frequency noise but may not be necessary. The LM95245 can handle capacitance up to $3.3\ \text{nF}$ (see Typical Performance Curve "Remote Temperature Reading Sensitivity to Thermal Diode Filter Capacitance"). Place the filter capacitors close to the LM95245 pins and make sure the traces to this capacitor are matched.
3. Ideally, the LM95245 should be placed within $10\ \text{cm}$ of the Processor diode pins with the traces being as straight, short and identical as possible. Trace resistance of $1\ \Omega$ can cause as much as 0.62°C of error. This error can be compensated by using simple software offset compensation.
4. Diode traces should be surrounded by a GND guard ring to either side, above and below if possible. This GND guard should not be between the D+ and D- lines. In the event that noise does couple to the diode lines it would be ideal if it is coupled common mode. That is equally to the D+ and D- lines.
5. Avoid routing diode traces in close proximity to power supply switching or filtering inductors.
6. Avoid running diode traces close to or parallel to high speed digital and bus lines. Diode traces should be kept at least $2\ \text{cm}$ apart from the high speed digital traces.
7. If it is necessary to cross high speed digital traces, the diode traces and the high speed digital traces should cross at a 90 degree angle.
8. The ideal place to connect the LM95245's GND pin is as close as possible to the Processors GND associated with the sense diode.
9. Leakage current between D+ and GND and between D+ and D- should be kept to a minimum. Thirteen nano-amperes of leakage can cause as much as 0.2°C of error in the diode temperature reading. Keeping the printed circuit board as clean as possible will minimize leakage current.

Noise coupling into the digital lines greater than 400 mVp-p (typical hysteresis) and undershoot less than 500 mV below GND, may prevent successful SMBus communication with the LM95245. SMBus no acknowledge is the most common symptom, causing unnecessary traffic on the bus. Although the SMBus maximum frequency of communication is rather low (100 kHz max), care still needs to be taken to ensure proper termination within a system with multiple parts on the bus and long printed circuit board traces. An RC lowpass filter with a 3 dB corner frequency of about 40 MHz is included on the LM95245's SMBCLK input. Additional resistance can be added in series with the SMBDAT and SMBCLK lines to further help filter noise and ringing. Minimize noise coupling by keeping digital traces out of switching power supply areas as well as ensuring that digital lines containing high speed data communications cross at right angles to the SMBDAT and SMBCLK lines.

REVISION HISTORY

Changes from Revision F (March 2013) to Revision G	Page
<hr/> <ul style="list-style-type: none">• Changed layout of National Data Sheet to TI format	<hr/> 28

PACKAGING INFORMATION

Orderable part number	Status (1)	Material type (2)	Package Pins	Package qty Carrier	RoHS (3)	Lead finish/ Ball material (4)	MSL rating/ Peak reflow (5)	Op temp (°C)	Part marking (6)
LM95245CIM/NOPB	Obsolete	Production	SOIC (D) 8	-	-	Call TI	Call TI	-	95245 CIM
LM95245CIMM	NRND	Production	VSSOP (DGK) 8	1000 SMALL T&R	No	SNPB	Level-1-260C-UNLIM	-40 to 125	T45C
LM95245CIMM-1/NOPB	Obsolete	Production	VSSOP (DGK) 8	-	-	Call TI	Call TI	-40 to 125	T46C
LM95245CIMM.A	NRND	Production	VSSOP (DGK) 8	1000 SMALL T&R	No	SNPB	Level-1-260C-UNLIM	-40 to 125	T45C
LM95245CIMM/NOPB	Obsolete	Production	VSSOP (DGK) 8	-	-	Call TI	Call TI	-40 to 125	T45C
LM95245CIMMX-1/NO.A	Active	Production	VSSOP (DGK) 8	3500 LARGE T&R	Yes	SN	Level-1-260C-UNLIM	-40 to 125	T46C
LM95245CIMMX-1/NOPB	Active	Production	VSSOP (DGK) 8	3500 LARGE T&R	Yes	SN	Level-1-260C-UNLIM	-40 to 125	T46C
LM95245CIMMX/NOPB	Active	Production	VSSOP (DGK) 8	3500 LARGE T&R	Yes	SN	Level-1-260C-UNLIM	-40 to 125	T45C
LM95245CIMMX/NOPB.A	Active	Production	VSSOP (DGK) 8	3500 LARGE T&R	Yes	SN	Level-1-260C-UNLIM	-40 to 125	T45C
LM95245CIMX/NOPB	Active	Production	SOIC (D) 8	2500 LARGE T&R	Yes	SN	Level-1-260C-UNLIM	-	95245 CIM
LM95245CIMX/NOPB.A	Active	Production	SOIC (D) 8	2500 LARGE T&R	Yes	SN	Level-1-260C-UNLIM	-40 to 125	95245 CIM

(1) **Status:** For more details on status, see our [product life cycle](#).

(2) **Material type:** When designated, preproduction parts are prototypes/experimental devices, and are not yet approved or released for full production. Testing and final process, including without limitation quality assurance, reliability performance testing, and/or process qualification, may not yet be complete, and this item is subject to further changes or possible discontinuation. If available for ordering, purchases will be subject to an additional waiver at checkout, and are intended for early internal evaluation purposes only. These items are sold without warranties of any kind.

(3) **RoHS values:** Yes, No, RoHS Exempt. See the [TI RoHS Statement](#) for additional information and value definition.

(4) **Lead finish/Ball material:** Parts may have multiple material finish options. Finish options are separated by a vertical ruled line. Lead finish/Ball material values may wrap to two lines if the finish value exceeds the maximum column width.

(5) **MSL rating/Peak reflow:** The moisture sensitivity level ratings and peak solder (reflow) temperatures. In the event that a part has multiple moisture sensitivity ratings, only the lowest level per JEDEC standards is shown. Refer to the shipping label for the actual reflow temperature that will be used to mount the part to the printed circuit board.

(6) **Part marking:** There may be an additional marking, which relates to the logo, the lot trace code information, or the environmental category of the part.

Multiple part markings will be inside parentheses. Only one part marking contained in parentheses and separated by a "~" will appear on a part. If a line is indented then it is a continuation of the previous line and the two combined represent the entire part marking for that device.

Important Information and Disclaimer: The information provided on this page represents TI's knowledge and belief as of the date that it is provided. TI bases its knowledge and belief on information provided by third parties, and makes no representation or warranty as to the accuracy of such information. Efforts are underway to better integrate information from third parties. TI has taken and continues to take reasonable steps to provide representative and accurate information but may not have conducted destructive testing or chemical analysis on incoming materials and chemicals. TI and TI suppliers consider certain information to be proprietary, and thus CAS numbers and other limited information may not be available for release.

In no event shall TI's liability arising out of such information exceed the total purchase price of the TI part(s) at issue in this document sold by TI to Customer on an annual basis.

TAPE AND REEL INFORMATION

QUADRANT ASSIGNMENTS FOR PIN 1 ORIENTATION IN TAPE

*All dimensions are nominal

Device	Package Type	Package Drawing	Pins	SPQ	Reel Diameter (mm)	Reel Width W1 (mm)	A0 (mm)	B0 (mm)	K0 (mm)	P1 (mm)	W (mm)	Pin1 Quadrant
LM95245CIMMX-1/NOPB	VSSOP	DGK	8	3500	330.0	12.4	5.3	3.4	1.4	8.0	12.0	Q1
LM95245CIMMX/NOPB	VSSOP	DGK	8	3500	330.0	12.4	5.3	3.4	1.4	8.0	12.0	Q1
LM95245CIMX/NOPB	SOIC	D	8	2500	330.0	12.4	6.5	5.4	2.0	8.0	12.0	Q1

TAPE AND REEL BOX DIMENSIONS

*All dimensions are nominal

Device	Package Type	Package Drawing	Pins	SPQ	Length (mm)	Width (mm)	Height (mm)
LM95245CIMMX-1/NOPB	VSSOP	DGK	8	3500	367.0	367.0	35.0
LM95245CIMMX/NOPB	VSSOP	DGK	8	3500	367.0	367.0	35.0
LM95245CIMX/NOPB	SOIC	D	8	2500	367.0	367.0	35.0

DGK0008A



PACKAGE OUTLINE

VSSOP - 1.1 mm max height

SMALL OUTLINE PACKAGE



4214862/A 04/2023

NOTES:

PowerPAD is a trademark of Texas Instruments.

1. All linear dimensions are in millimeters. Any dimensions in parenthesis are for reference only. Dimensioning and tolerancing per ASME Y14.5M.
2. This drawing is subject to change without notice.
3. This dimension does not include mold flash, protrusions, or gate burrs. Mold flash, protrusions, or gate burrs shall not exceed 0.15 mm per side.
4. This dimension does not include interlead flash. Interlead flash shall not exceed 0.25 mm per side.
5. Reference JEDEC registration MO-187.

EXAMPLE BOARD LAYOUT

DGK0008A

™ VSSOP - 1.1 mm max height

SMALL OUTLINE PACKAGE



LAND PATTERN EXAMPLE
EXPOSED METAL SHOWN
SCALE: 15X



SOLDER MASK DETAILS

4214862/A 04/2023

NOTES: (continued)

6. Publication IPC-7351 may have alternate designs.
7. Solder mask tolerances between and around signal pads can vary based on board fabrication site.
8. Vias are optional depending on application, refer to device data sheet. If any vias are implemented, refer to their locations shown on this view. It is recommended that vias under paste be filled, plugged or tented.
9. Size of metal pad may vary due to creepage requirement.

EXAMPLE STENCIL DESIGN

DGK0008A

TM VSSOP - 1.1 mm max height

SMALL OUTLINE PACKAGE



SOLDER PASTE EXAMPLE
SCALE: 15X

4214862/A 04/2023

NOTES: (continued)

11. Laser cutting apertures with trapezoidal walls and rounded corners may offer better paste release. IPC-7525 may have alternate design recommendations.
12. Board assembly site may have different recommendations for stencil design.



D0008A

PACKAGE OUTLINE

SOIC - 1.75 mm max height

SMALL OUTLINE INTEGRATED CIRCUIT



4214825/C 02/2019

NOTES:

1. Linear dimensions are in inches [millimeters]. Dimensions in parenthesis are for reference only. Controlling dimensions are in inches. Dimensioning and tolerancing per ASME Y14.5M.
2. This drawing is subject to change without notice.
3. This dimension does not include mold flash, protrusions, or gate burrs. Mold flash, protrusions, or gate burrs shall not exceed $.006$ [0.15] per side.
4. This dimension does not include interlead flash.
5. Reference JEDEC registration MS-012, variation AA.

EXAMPLE BOARD LAYOUT

D0008A

SOIC - 1.75 mm max height

SMALL OUTLINE INTEGRATED CIRCUIT



LAND PATTERN EXAMPLE
 EXPOSED METAL SHOWN
 SCALE:8X



SOLDER MASK DETAILS

4214825/C 02/2019

NOTES: (continued)

- 6. Publication IPC-7351 may have alternate designs.
- 7. Solder mask tolerances between and around signal pads can vary based on board fabrication site.

EXAMPLE STENCIL DESIGN

D0008A

SOIC - 1.75 mm max height

SMALL OUTLINE INTEGRATED CIRCUIT



SOLDER PASTE EXAMPLE
BASED ON .005 INCH [0.125 MM] THICK STENCIL
SCALE:8X

4214825/C 02/2019

NOTES: (continued)

8. Laser cutting apertures with trapezoidal walls and rounded corners may offer better paste release. IPC-7525 may have alternate design recommendations.
9. Board assembly site may have different recommendations for stencil design.

IMPORTANT NOTICE AND DISCLAIMER

TI PROVIDES TECHNICAL AND RELIABILITY DATA (INCLUDING DATASHEETS), DESIGN RESOURCES (INCLUDING REFERENCE DESIGNS), APPLICATION OR OTHER DESIGN ADVICE, WEB TOOLS, SAFETY INFORMATION, AND OTHER RESOURCES "AS IS" AND WITH ALL FAULTS, AND DISCLAIMS ALL WARRANTIES, EXPRESS AND IMPLIED, INCLUDING WITHOUT LIMITATION ANY IMPLIED WARRANTIES OF MERCHANTABILITY, FITNESS FOR A PARTICULAR PURPOSE OR NON-INFRINGEMENT OF THIRD PARTY INTELLECTUAL PROPERTY RIGHTS.

These resources are intended for skilled developers designing with TI products. You are solely responsible for (1) selecting the appropriate TI products for your application, (2) designing, validating and testing your application, and (3) ensuring your application meets applicable standards, and any other safety, security, regulatory or other requirements.

These resources are subject to change without notice. TI grants you permission to use these resources only for development of an application that uses the TI products described in the resource. Other reproduction and display of these resources is prohibited. No license is granted to any other TI intellectual property right or to any third party intellectual property right. TI disclaims responsibility for, and you fully indemnify TI and its representatives against any claims, damages, costs, losses, and liabilities arising out of your use of these resources.

TI's products are provided subject to [TI's Terms of Sale](#), [TI's General Quality Guidelines](#), or other applicable terms available either on ti.com or provided in conjunction with such TI products. TI's provision of these resources does not expand or otherwise alter TI's applicable warranties or warranty disclaimers for TI products. Unless TI explicitly designates a product as custom or customer-specified, TI products are standard, catalog, general purpose devices.

TI objects to and rejects any additional or different terms you may propose.

Copyright © 2025, Texas Instruments Incorporated

Last updated 10/2025