

FPC401 Quad Port Controller

1 Features

- Supports Control Signal Management and I2C Aggregation Across Four Ports
- Combine Multiple FPC401s to Control 56 Total Ports Through a Single Host Interface
- Eliminates Need for Discrete I2C Muxes, LED Drivers, and High-Pin-Count FPGA/CPLD Control Devices
- Reduces PCB Routing Complexity by Handling All Low-Speed Control Signals Close to the Port
- Selectable I2C (Up to 1 MHz) or SPI (Up to 10 MHz) Host Control Interface
- Automatic Pre-Fetching of Critical, User-Specified Data From the Modules
- Low Single-Port and Multi-Port Read/Write Latency: <math><50 \mu\text{s}</math> for SPI Mode, <math><400 \mu\text{s}</math> for I2C Mode
- Broadcast Mode Allows Writes to All Ports Simultaneously Across All FPC401 Controllers
- Advanced LED Features for Port Status Indication, Including Programmable Blinking and Dimming
- Customizable Interrupt Events
- Separate Host-Side I/O Voltage: 1.8-V to 3.3-V
- Small QFN Package Enabling Placement on Bottom Side of PCB Underneath Ports

2 Applications

- ToR/Aggregation/Core Switch and Router SFP+/QSFP+ Port Control
- SAS External Cable Management Interface Control
- Video Switch & Router SFP+/QSFP+ Port Control

3 Description

The FPC401 quad port controller serves as a low-speed signal aggregator for common port types such as SFP+, QSFP+, and SAS. The FPC401 aggregates all low-speed control and I2C signals across four ports and presents a single easy-to-use management interface to the host (I2C or SPI). Multiple FPC401s can be used in high-port-count applications with one common control interface to the host. The FPC401 is designed to allow placement on the bottom side of the PCB, underneath the press fit connector, to simplify routing. This localized control of the ports' low-speed signals cuts system BOM cost by enabling the use of smaller IO count control devices (FPGAs, CPLDs, MCUs) and by reducing routing layer congestion.

Device Information⁽¹⁾

PART NUMBER	PACKAGE	BODY SIZE (NOM)
FPC401	QFN (56)	5.00 mm x 11.00 mm

(1) For all available packages, see the orderable addendum at the end of the data sheet.

Simplified Block Diagram

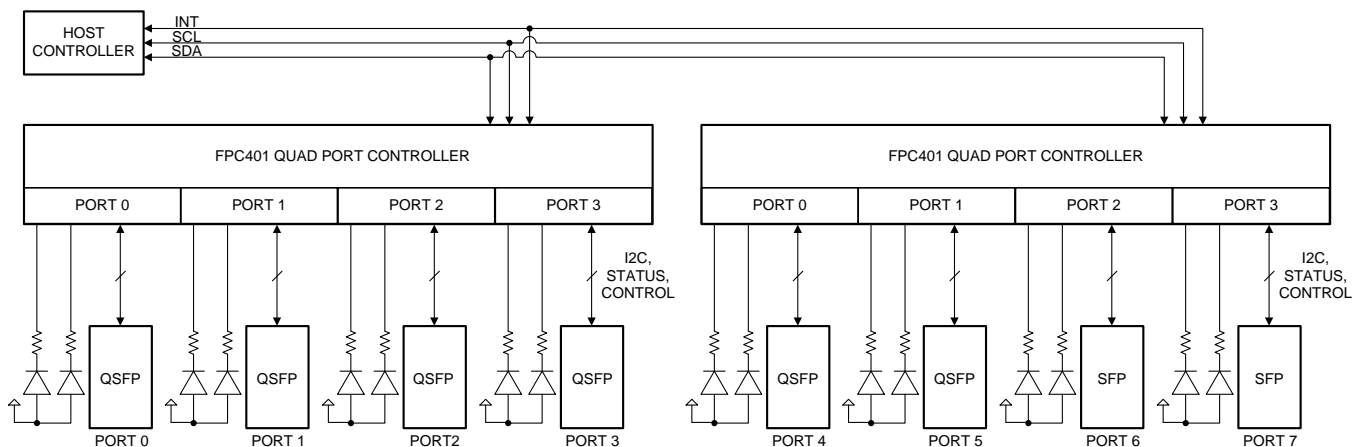

Copyright © 2016, Texas Instruments Incorporated



Table of Contents

<p>1 Features 1</p> <p>2 Applications 1</p> <p>3 Description 1</p> <p>4 Revision History..... 2</p> <p>5 Description (continued)..... 3</p> <p>6 Device and Documentation Support..... 4</p> <p style="padding-left: 20px;">6.1 Documentation Support 4</p>	<p>6.2 Receiving Notification of Documentation Updates.... 4</p> <p>6.3 Community Resources..... 4</p> <p>6.4 Trademarks 4</p> <p>6.5 Electrostatic Discharge Caution 4</p> <p>6.6 Glossary 4</p> <p>7 Mechanical, Packaging, and Orderable Information 4</p>
---	--

4 Revision History

NOTE: Page numbers for previous revisions may differ from page numbers in the current version.

DATE	REVISION	NOTES
December 2016	*	Initial release.

5 Description (continued)

The FPC401 is compatible with standard SFF-8431, SFF-8436, and SFF-8449 low-speed management interfaces, including a dedicated 100-kHz and 400-kHz I2C interface to each port. Additional general-purpose pins are available to perform functions such as driving port status LEDs or controlling power switches. The LED drivers have convenience features such as programmable blinking and dimming. The interface to the host controller can operate on a separate supply voltage between 1.8-V and 3.3-V to support low-voltage I/Os.

The FPC401 can prefetch data from user-specified registers in each module, making the data readily accessible to the host through a fast I2C (up to 1 MHz) or SPI (up to 10 MHz) interface. In addition, the FPC401 can trigger an interrupt to the host whenever critical, user-configurable events occur associated with any of the ports under its control. This eliminates the need to continuously poll the modules.

6 Device and Documentation Support

6.1 Documentation Support

6.1.1 Related Documentation

For related documentation, see the following:

- *FPC401 Programmer's Guide* (SNLU221)
- *FPC401 Evaluation Module (EVM) User's Guide* (SNLU222)

Click [here](#) to request access to these documents in the FPC401 MySecure folder.

6.2 Receiving Notification of Documentation Updates

To receive notification of documentation updates, navigate to the device product folder on ti.com. In the upper right corner, click on *Alert me* to register and receive a weekly digest of any product information that has changed. For change details, review the revision history included in any revised document.

6.3 Community Resources

The following links connect to TI community resources. Linked contents are provided "AS IS" by the respective contributors. They do not constitute TI specifications and do not necessarily reflect TI's views; see TI's [Terms of Use](#).

TI E2E™ Online Community *TI's Engineer-to-Engineer (E2E) Community*. Created to foster collaboration among engineers. At e2e.ti.com, you can ask questions, share knowledge, explore ideas and help solve problems with fellow engineers.

Design Support *TI's Design Support* Quickly find helpful E2E forums along with design support tools and contact information for technical support.

6.4 Trademarks

E2E is a trademark of Texas Instruments.
All other trademarks are the property of their respective owners.

6.5 Electrostatic Discharge Caution



This integrated circuit can be damaged by ESD. Texas Instruments recommends that all integrated circuits be handled with appropriate precautions. Failure to observe proper handling and installation procedures can cause damage.

ESD damage can range from subtle performance degradation to complete device failure. Precision integrated circuits may be more susceptible to damage because very small parametric changes could cause the device not to meet its published specifications.

6.6 Glossary

[SLYZ022](#) — *TI Glossary*.

This glossary lists and explains terms, acronyms, and definitions.

7 Mechanical, Packaging, and Orderable Information

The following pages include mechanical, packaging, and orderable information. This information is the most current data available for the designated devices. This data is subject to change without notice and revision of this document. For browser-based versions of this data sheet, refer to the left-hand navigation.

PACKAGING INFORMATION

Orderable part number	Status (1)	Material type (2)	Package Pins	Package qty Carrier	RoHS (3)	Lead finish/ Ball material (4)	MSL rating/ Peak reflow (5)	Op temp (°C)	Part marking (6)
FPC401RHUR	Active	Production	WQFN (RHU) 56	2000 LARGE T&R	Yes	SN	Level-2-260C-1 YEAR	-40 to 85	FPC401
FPC401RHUR.A	Active	Production	WQFN (RHU) 56	2000 LARGE T&R	Yes	SN	Level-2-260C-1 YEAR	-40 to 85	FPC401
FPC401RHUT.A	Active	Production	WQFN (RHU) 56	250 SMALL T&R	Yes	SN	Level-2-260C-1 YEAR	-40 to 85	FPC401

(1) **Status:** For more details on status, see our [product life cycle](#).

(2) **Material type:** When designated, preproduction parts are prototypes/experimental devices, and are not yet approved or released for full production. Testing and final process, including without limitation quality assurance, reliability performance testing, and/or process qualification, may not yet be complete, and this item is subject to further changes or possible discontinuation. If available for ordering, purchases will be subject to an additional waiver at checkout, and are intended for early internal evaluation purposes only. These items are sold without warranties of any kind.

(3) **RoHS values:** Yes, No, RoHS Exempt. See the [TI RoHS Statement](#) for additional information and value definition.

(4) **Lead finish/Ball material:** Parts may have multiple material finish options. Finish options are separated by a vertical ruled line. Lead finish/Ball material values may wrap to two lines if the finish value exceeds the maximum column width.

(5) **MSL rating/Peak reflow:** The moisture sensitivity level ratings and peak solder (reflow) temperatures. In the event that a part has multiple moisture sensitivity ratings, only the lowest level per JEDEC standards is shown. Refer to the shipping label for the actual reflow temperature that will be used to mount the part to the printed circuit board.

(6) **Part marking:** There may be an additional marking, which relates to the logo, the lot trace code information, or the environmental category of the part.

Multiple part markings will be inside parentheses. Only one part marking contained in parentheses and separated by a "-" will appear on a part. If a line is indented then it is a continuation of the previous line and the two combined represent the entire part marking for that device.

Important Information and Disclaimer: The information provided on this page represents TI's knowledge and belief as of the date that it is provided. TI bases its knowledge and belief on information provided by third parties, and makes no representation or warranty as to the accuracy of such information. Efforts are underway to better integrate information from third parties. TI has taken and continues to take reasonable steps to provide representative and accurate information but may not have conducted destructive testing or chemical analysis on incoming materials and chemicals. TI and TI suppliers consider certain information to be proprietary, and thus CAS numbers and other limited information may not be available for release.

In no event shall TI's liability arising out of such information exceed the total purchase price of the TI part(s) at issue in this document sold by TI to Customer on an annual basis.

TAPE AND REEL INFORMATION

QUADRANT ASSIGNMENTS FOR PIN 1 ORIENTATION IN TAPE

*All dimensions are nominal

Device	Package Type	Package Drawing	Pins	SPQ	Reel Diameter (mm)	Reel Width W1 (mm)	A0 (mm)	B0 (mm)	K0 (mm)	P1 (mm)	W (mm)	Pin1 Quadrant
FPC401RHUR	WQFN	RHU	56	2000	330.0	24.4	5.3	11.3	1.0	8.0	24.0	Q1

TAPE AND REEL BOX DIMENSIONS

*All dimensions are nominal

Device	Package Type	Package Drawing	Pins	SPQ	Length (mm)	Width (mm)	Height (mm)
FPC401RHUR	WQFN	RHU	56	2000	356.0	356.0	45.0

RHU0056A



PACKAGE OUTLINE

WQFN - 0.8 mm max height

PLASTIC QUAD FLATPACK - NO LEAD

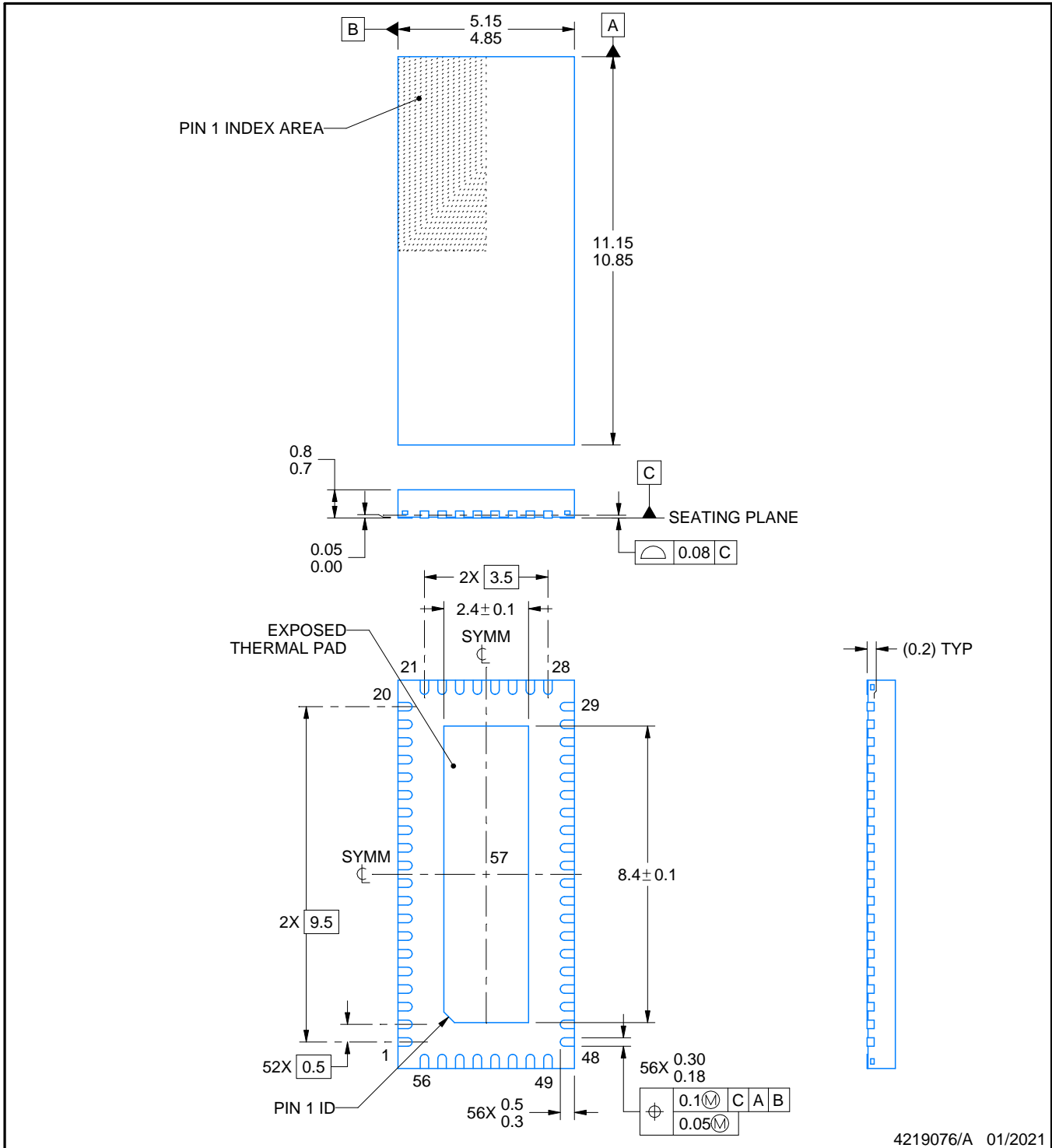

4219076/A 01/2021

NOTES:

1. All linear dimensions are in millimeters. Any dimensions in parenthesis are for reference only. Dimensioning and tolerancing per ASME Y14.5M.
2. This drawing is subject to change without notice.
3. The package thermal pad must be soldered to the printed circuit board for thermal and mechanical performance.

EXAMPLE BOARD LAYOUT

RHU0056A

WQFN - 0.8 mm max height

PLASTIC QUAD FLATPACK - NO LEAD

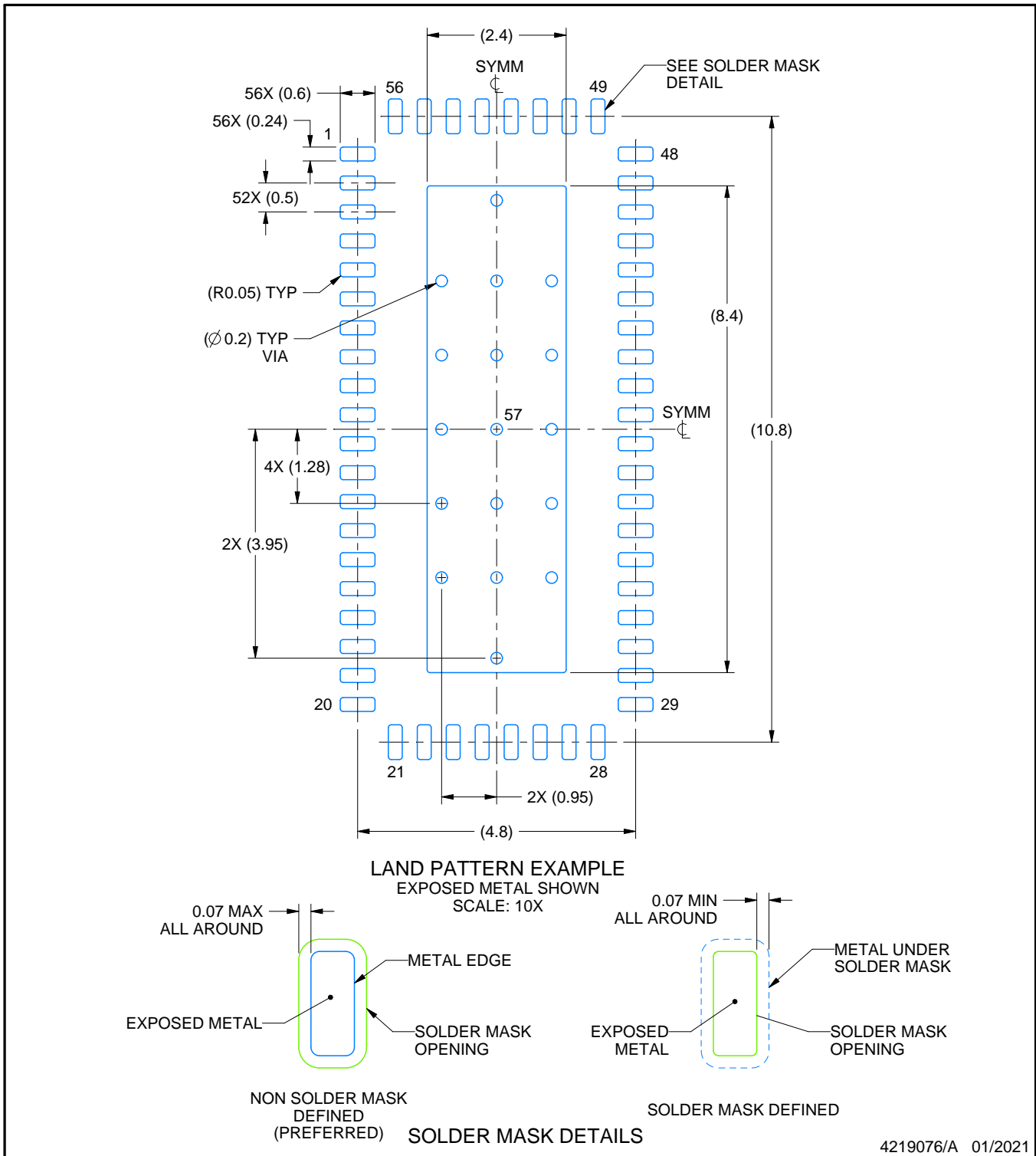

4219076/A 01/2021

NOTES: (continued)

4. This package is designed to be soldered to a thermal pad on the board. For more information, see Texas Instruments literature number SLUA271 (www.ti.com/lit/sluea271).
5. Vias are optional depending on application, refer to device data sheet. If any vias are implemented, refer to their locations shown on this view. It is recommended that vias under paste be filled, plugged or tented.

EXAMPLE STENCIL DESIGN

RHU0056A

WQFN - 0.8 mm max height

PLASTIC QUAD FLATPACK - NO LEAD

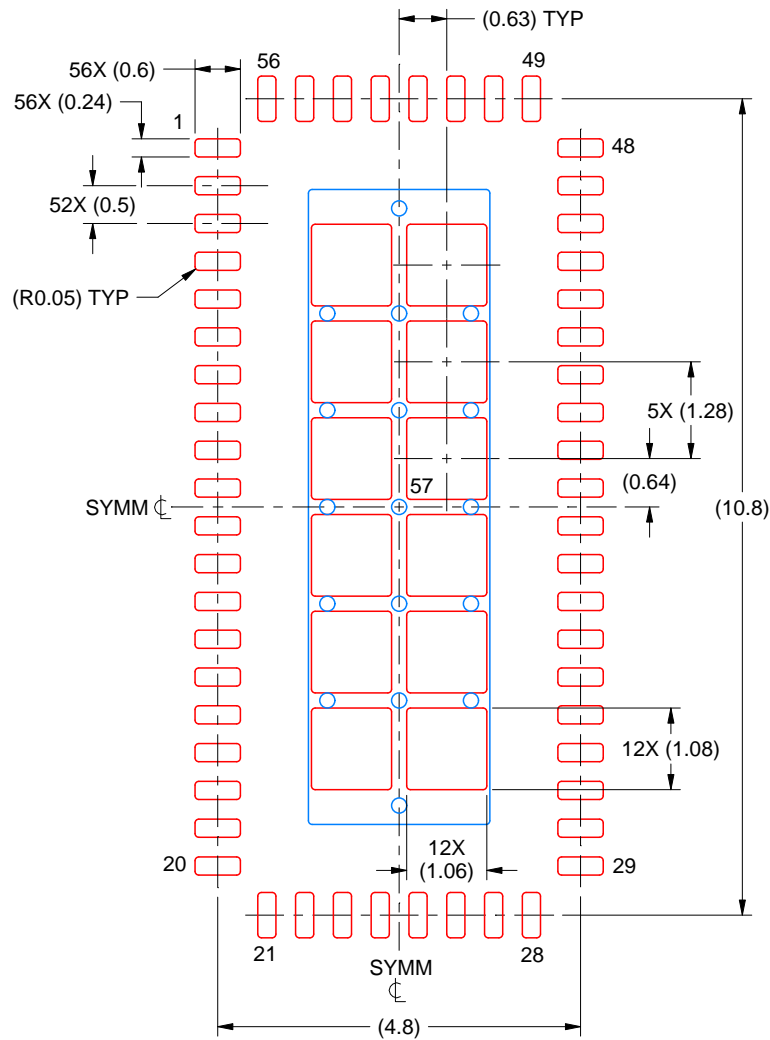

SOLDER PASTE EXAMPLE
 BASED ON 0.125 MM THICK STENCIL
 SCALE: 10X

EXPOSED PAD 57
 68% PRINTED SOLDER COVERAGE BY AREA UNDER PACKAGE

4219076/A 01/2021

NOTES: (continued)

6. Laser cutting apertures with trapezoidal walls and rounded corners may offer better paste release. IPC-7525 may have alternate design recommendations.

IMPORTANT NOTICE AND DISCLAIMER

TI PROVIDES TECHNICAL AND RELIABILITY DATA (INCLUDING DATA SHEETS), DESIGN RESOURCES (INCLUDING REFERENCE DESIGNS), APPLICATION OR OTHER DESIGN ADVICE, WEB TOOLS, SAFETY INFORMATION, AND OTHER RESOURCES "AS IS" AND WITH ALL FAULTS, AND DISCLAIMS ALL WARRANTIES, EXPRESS AND IMPLIED, INCLUDING WITHOUT LIMITATION ANY IMPLIED WARRANTIES OF MERCHANTABILITY, FITNESS FOR A PARTICULAR PURPOSE OR NON-INFRINGEMENT OF THIRD PARTY INTELLECTUAL PROPERTY RIGHTS.

These resources are intended for skilled developers designing with TI products. You are solely responsible for (1) selecting the appropriate TI products for your application, (2) designing, validating and testing your application, and (3) ensuring your application meets applicable standards, and any other safety, security, regulatory or other requirements.

These resources are subject to change without notice. TI grants you permission to use these resources only for development of an application that uses the TI products described in the resource. Other reproduction and display of these resources is prohibited. No license is granted to any other TI intellectual property right or to any third party intellectual property right. TI disclaims responsibility for, and you will fully indemnify TI and its representatives against, any claims, damages, costs, losses, and liabilities arising out of your use of these resources.

TI's products are provided subject to [TI's Terms of Sale](#) or other applicable terms available either on [ti.com](https://www.ti.com) or provided in conjunction with such TI products. TI's provision of these resources does not expand or otherwise alter TI's applicable warranties or warranty disclaimers for TI products.

TI objects to and rejects any additional or different terms you may have proposed.

Mailing Address: Texas Instruments, Post Office Box 655303, Dallas, Texas 75265

Copyright © 2025, Texas Instruments Incorporated