

# DLP9500UV DLP® 0.95-Inch UV 1080p 2x LVDS Type A Digital Micromirror Device

## 1 Features

- 0.95-Inch diagonal micromirror array
  - 1920 × 1080 array of aluminum, micrometer-sized mirrors (1080p resolution)
  - 10.8µm micromirror pitch
  - ±12° micromirror tilt angle (relative to flat state)
  - Designed for corner illumination
- Designed for use with UV light (363nm to 420nm):
  - Window transmission 98% (Single Pass, Through Two Window Surfaces) (nominal)
  - Micromirror reflectivity 88% (Nominal)
  - Array diffraction efficiency 85% (Nominal)
  - Array fill factor 94% (Nominal)
- Four 16-bit, low-voltage differential signaling (LVDS), double data rate (DDR) input data buses
- Up to 400MHz input data clock rate
- 42.2mm × 42.2mm × 7mm package footprint
- Hermetic package

## 2 Applications

- Industrial:
  - Direct imaging lithography
  - Laser marking and repair systems
  - Computer to plate printers
  - Rapid prototype machines
  - 3D printers
- Medical:
  - Ophthalmology
  - Photo therapy
  - Hyper-spectral imaging

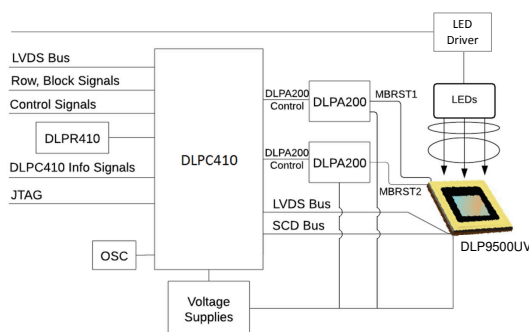

**Simplified Schematic**

## 3 Description

DLP9500UV is a digitally controlled micro-electromechanical system (MEMS) spatial light modulator (SLM). When coupled to an appropriate optical system, the DLP9500UV can be used to modulate the amplitude, direction, and/or phase of incoming light.

The DLP9500UV chipset is a new digital micromirror device (DMD) addition to the DLP® Discovery™ 4100 platform, which enables high resolution and high-performance spatial light modulation beyond the visible spectrum into the UVA spectrum (363nm to 420nm). The DLP9500UV DMD is designed with a special window that is optimized for UV transmission.

The DLP9500UV is the 0.95 1080p DMD, with a hermetic package, that is sold with a dedicated DLPC410 controller required for high-speed pattern rates of >23000Hz (1-bit binary) and >1700Hz (8-bit gray), one unit DLPR410 (DLP Discovery 4100 Configuration PROM), and two units DLPA200 (DMD micromirror drivers). Refer to the DLPC410, DLPA200, DLPR410, and DLP9500UV Functional Block Diagram.

Reliable function and operation of the DLP9500UV requires that it be used in conjunction with the other components of the chipset. A dedicated chipset provides developers with easier access to the DMD as well as high-speed, independent micromirror control.

DLP9500UV is a digitally controlled micro-electromechanical system (MEMS) spatial light modulator (SLM). When coupled to an appropriate optical system, the DLP9500UV can be used to modulate the amplitude, direction, and/or phase of incoming light.

### Device Information (1)

PART NUMBER	PACKAGE	PACKAGE SIZE
DLP9500UV	LCCC (355)	42.16mm × 42.16mm x 7.00 mm

(1) For more information, see the *Mechanical, Packaging, and Orderable* addendum.



## Table of Contents

<b>1 Features</b> .....	1	7.3 Feature Description.....	26
<b>2 Applications</b> .....	1	7.4 Device Functional Modes.....	33
<b>3 Description</b> .....	1	7.5 Window Characteristics and Optics.....	35
<b>4 Description (continued)</b> .....	3	7.6 Micromirror Array Temperature Calculation.....	36
<b>5 Pin Configuration and Functions</b> .....	3	7.7 Micromirror Landed-On and Landed-Off Duty Cycle.....	38
Pin Functions.....	4	<b>8 Application and Implementation</b> .....	40
<b>6 Specifications</b> .....	13	8.1 Application Information.....	40
6.1 Absolute Maximum Ratings.....	13	8.2 Typical Application.....	42
6.2 Storage Conditions.....	13	8.3 Power Supply Recommendations.....	44
6.3 ESD Ratings.....	13	8.4 Layout.....	45
6.4 Recommended Operating Conditions.....	14	<b>9 Device and Documentation Support</b> .....	48
6.5 Thermal Information.....	15	9.1 Device Support.....	48
6.6 Electrical Characteristics.....	16	9.2 Documentation Support.....	49
6.7 LVDS Timing Requirements.....	17	9.3 Related Links.....	49
6.8 LVDS Waveform Requirements.....	18	9.4 Support Resources.....	49
6.9 Serial Control Bus Timing Requirements.....	19	9.5 Trademarks.....	49
6.10 Systems Mounting Interface Loads.....	20	9.6 Electrostatic Discharge Caution.....	49
6.11 Micromirror Array Physical Characteristics.....	21	9.7 Glossary.....	49
6.12 Micromirror Array Optical Characteristics.....	22	<b>10 Revision History</b> .....	49
6.13 Chipset Component Usage Specification.....	23	<b>11 Mechanical, Packaging, and Orderable Information</b> .....	50
<b>7 Detailed Description</b> .....	24		
7.1 Overview.....	24		
7.2 Functional Block Diagram.....	24		

## 4 Description (continued)

Electrically, the DLP9500UV consists of a two-dimensional array of 1-bit CMOS memory cells, organized in a grid of 1920 memory cell columns by 1080 memory cell rows. The CMOS memory array is addressed on a row-by-row basis, over four 16-bit LVDS DDR buses. Addressing is handled by a serial control bus. The specific CMOS memory access protocol is handled by the DLPC410 digital controller.

## 5 Pin Configuration and Functions

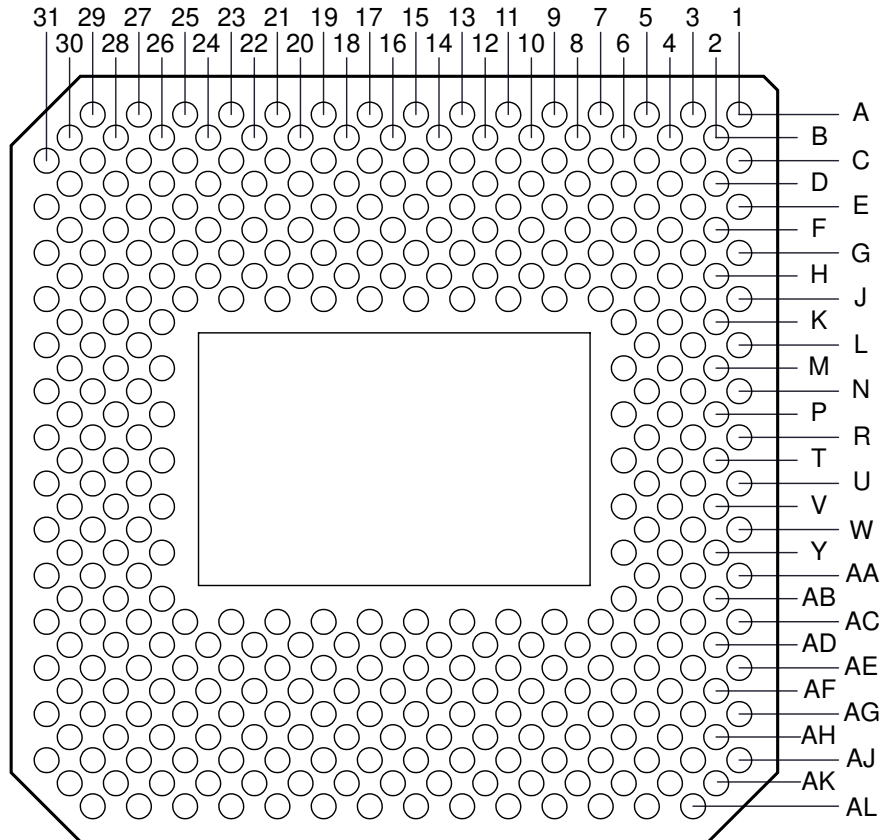

**Figure 5-1. FLN Package 355-Pin LCCC Bottom View**

### Pin Functions

PIN <sup>(1)</sup>		TYPE (I/O/P)	SIGNAL	DATA RATE <sup>(2)</sup>	INTERNAL TERM <sup>(3)</sup>	CLOCK	DESCRIPTION	TRACE (MILS)
NAME	NO.							
<b>DATA BUS A</b>								
D_AN(0)	F2	Input	LVC MOS	DDR	Differentially terminated – 100Ω	DCLK_A	Input data bus A (2x LVDS)	512.01
D_AN(1)	H8	Input	LVC MOS	DDR	Differentially terminated – 100Ω	DCLK_A		158.79
D_AN(2)	E5	Input	LVC MOS	DDR	Differentially terminated – 100Ω	DCLK_A		471.24
D_AN(3)	G9	Input	LVC MOS	DDR	Differentially terminated – 100Ω	DCLK_A		159.33
D_AN(4)	D2	Input	LVC MOS	DDR	Differentially terminated – 100Ω	DCLK_A		585.41
D_AN(5)	G3	Input	LVC MOS	DDR	Differentially terminated – 100Ω	DCLK_A		551.17
D_AN(6)	E11	Input	LVC MOS	DDR	Differentially terminated – 100Ω	DCLK_A		229.41
D_AN(7)	F8	Input	LVC MOS	DDR	Differentially terminated – 100Ω	DCLK_A		300.54
D_AN(8)	C9	Input	LVC MOS	DDR	Differentially terminated – 100Ω	DCLK_A		346.35
D_AN(9)	H2	Input	LVC MOS	DDR	Differentially terminated – 100Ω	DCLK_A		782.27
D_AN(10)	B10	Input	LVC MOS	DDR	Differentially terminated – 100Ω	DCLK_A		451.52
D_AN(11)	G15	Input	LVC MOS	DDR	Differentially terminated – 100Ω	DCLK_A		74.39
D_AN(12)	D14	Input	LVC MOS	DDR	Differentially terminated – 100Ω	DCLK_A		194.26
D_AN(13)	F14	Input	LVC MOS	DDR	Differentially terminated – 100Ω	DCLK_A		148.29
D_AN(14)	C17	Input	LVC MOS	DDR	Differentially terminated – 100Ω	DCLK_A		244.9
D_AN(15)	H16	Input	LVC MOS	DDR	Differentially terminated – 100Ω	DCLK_A	73.39	
D_AP(0)	F4	Input	LVC MOS	DDR	Differentially terminated – 100Ω	DCLK_A	Input data bus A (2x LVDS)	509.63
D_AP(1)	H10	Input	LVC MOS	DDR	Differentially terminated – 100Ω	DCLK_A		152.59
D_AP(2)	E3	Input	LVC MOS	DDR	Differentially terminated – 100Ω	DCLK_A		464.09
D_AP(3)	G11	Input	LVC MOS	DDR	Differentially terminated – 100Ω	DCLK_A		152.39
D_AP(4)	D4	Input	LVC MOS	DDR	Differentially terminated – 100Ω	DCLK_A		591.39
D_AP(5)	G5	Input	LVC MOS	DDR	Differentially terminated – 100Ω	DCLK_A		532.16
D_AP(6)	E9	Input	LVC MOS	DDR	Differentially terminated – 100Ω	DCLK_A		230.78
D_AP(7)	F10	Input	LVC MOS	DDR	Differentially terminated – 100Ω	DCLK_A		300.61
D_AP(8)	C11	Input	LVC MOS	DDR	Differentially terminated – 100Ω	DCLK_A		338.16
D_AP(9)	H4	Input	LVC MOS	DDR	Differentially terminated – 100Ω	DCLK_A		773.17
D_AP(10)	B8	Input	LVC MOS	DDR	Differentially terminated – 100Ω	DCLK_A		449.57
D_AP(11)	H14	Input	LVC MOS	DDR	Differentially terminated – 100Ω	DCLK_A		71.7
D_AP(12)	D16	Input	LVC MOS	DDR	Differentially terminated – 100Ω	DCLK_A		198.69
D_AP(13)	F16	Input	LVC MOS	DDR	Differentially terminated – 100Ω	DCLK_A		143.72
D_AP(14)	C15	Input	LVC MOS	DDR	Differentially terminated – 100Ω	DCLK_A		240.14
D_AP(15)	G17	Input	LVC MOS	DDR	Differentially terminated – 100Ω	DCLK_A	74.05	

PIN <sup>(1)</sup>		TYPE (I/O/P)	SIGNAL	DATA RATE <sup>(2)</sup>	INTERNAL TERM <sup>(3)</sup>	CLOCK	DESCRIPTION	TRACE (MILS)
NAME	NO.							
<b>DATA BUS B</b>								
D_BN(0)	AH2	Input	LVC MOS	DDR	Differentially terminated – 100Ω	DCLK_B	Input data bus B (2x LVDS)	525.25
D_BN(1)	AD8	Input	LVC MOS	DDR	Differentially terminated – 100Ω	DCLK_B		190.59
D_BN(2)	AJ5	Input	LVC MOS	DDR	Differentially terminated – 100Ω	DCLK_B		525.25
D_BN(3)	AE3	Input	LVC MOS	DDR	Differentially terminated – 100Ω	DCLK_B		494.91
D_BN(4)	AG9	Input	LVC MOS	DDR	Differentially terminated – 100Ω	DCLK_B		222.67
D_BN(5)	AE11	Input	LVC MOS	DDR	Differentially terminated – 100Ω	DCLK_B		205.45
D_BN(6)	AH10	Input	LVC MOS	DDR	Differentially terminated – 100Ω	DCLK_B		309.05
D_BN(7)	AF10	Input	LVC MOS	DDR	Differentially terminated – 100Ω	DCLK_B		285.62
D_BN(8)	AK8	Input	LVC MOS	DDR	Differentially terminated – 100Ω	DCLK_B		483.58
D_BN(9)	AG5	Input	LVC MOS	DDR	Differentially terminated – 100Ω	DCLK_B		711.58
D_BN(10)	AL11	Input	LVC MOS	DDR	Differentially terminated – 100Ω	DCLK_B		462.21
D_BN(11)	AE15	Input	LVC MOS	DDR	Differentially terminated – 100Ω	DCLK_B		74.39
D_BN(12)	AH14	Input	LVC MOS	DDR	Differentially terminated – 100Ω	DCLK_B		194.26
D_BN(13)	AF14	Input	LVC MOS	DDR	Differentially terminated – 100Ω	DCLK_B		156
D_BN(14)	AJ17	Input	LVC MOS	DDR	Differentially terminated – 100Ω	DCLK_B		247.9
D_BN(15)	AD16	Input	LVC MOS	DDR	Differentially terminated – 100Ω	DCLK_B	111.52	
D_BP(0)	AH4	Input	LVC MOS	DDR	Differentially terminated – 100Ω	DCLK_B	Input data bus B (2x LVDS)	525.02
D_BP(1)	AD10	Input	LVC MOS	DDR	Differentially terminated – 100Ω	DCLK_B		190.61
D_BP(2)	AJ3	Input	LVC MOS	DDR	Differentially terminated – 100Ω	DCLK_B		524.22
D_BP(3)	AE5	Input	LVC MOS	DDR	Differentially terminated – 100Ω	DCLK_B		476.07
D_BP(4)	AG11	Input	LVC MOS	DDR	Differentially terminated – 100Ω	DCLK_B		222.8
D_BP(5)	AE9	Input	LVC MOS	DDR	Differentially terminated – 100Ω	DCLK_B		219.48
D_BP(6)	AH8	Input	LVC MOS	DDR	Differentially terminated – 100Ω	DCLK_B		306.55
D_BP(7)	AF8	Input	LVC MOS	DDR	Differentially terminated – 100Ω	DCLK_B		298.04
D_BP(8)	AK10	Input	LVC MOS	DDR	Differentially terminated – 100Ω	DCLK_B		480.31
D_BP(9)	AG3	Input	LVC MOS	DDR	Differentially terminated – 100Ω	DCLK_B		727.18
D_BP(10)	AL9	Input	LVC MOS	DDR	Differentially terminated – 100Ω	DCLK_B		461.02
D_BP(11)	AD14	Input	LVC MOS	DDR	Differentially terminated – 100Ω	DCLK_B		71.35
D_BP(12)	AH16	Input	LVC MOS	DDR	Differentially terminated – 100Ω	DCLK_B		197.69
D_BP(13)	AF16	Input	LVC MOS	DDR	Differentially terminated – 100Ω	DCLK_B		150.38
D_BP(14)	AJ15	Input	LVC MOS	DDR	Differentially terminated – 100Ω	DCLK_B		243.14
D_BP(15)	AE17	Input	LVC MOS	DDR	Differentially terminated – 100Ω	DCLK_B	113.36	

PIN <sup>(1)</sup>		TYPE (I/O/P)	SIGNAL	DATA RATE <sup>(2)</sup>	INTERNAL TERM <sup>(3)</sup>	CLOCK	DESCRIPTION	TRACE (MILS)
NAME	NO.							
<b>DATA BUS C</b>								
D_CN(0)	B14	Input	LVC MOS	DDR	Differentially terminated – 100Ω	DCLK_C	Input data bus C (2x LVDS)	459.04
D_CN(1)	E15	Input	LVC MOS	DDR	Differentially terminated – 100Ω	DCLK_C		342.79
D_CN(2)	A17	Input	LVC MOS	DDR	Differentially terminated – 100Ω	DCLK_C		456.22
D_CN(3)	G21	Input	LVC MOS	DDR	Differentially terminated – 100Ω	DCLK_C		68.24
D_CN(4)	B20	Input	LVC MOS	DDR	Differentially terminated – 100Ω	DCLK_C		362.61
D_CN(5)	F20	Input	LVC MOS	DDR	Differentially terminated – 100Ω	DCLK_C		163.07
D_CN(6)	D22	Input	LVC MOS	DDR	Differentially terminated – 100Ω	DCLK_C		204.16
D_CN(7)	G23	Input	LVC MOS	DDR	Differentially terminated – 100Ω	DCLK_C		105.59
D_CN(8)	B26	Input	LVC MOS	DDR	Differentially terminated – 100Ω	DCLK_C		450.51
D_CN(9)	F28	Input	LVC MOS	DDR	Differentially terminated – 100Ω	DCLK_C		302.04
D_CN(10)	C29	Input	LVC MOS	DDR	Differentially terminated – 100Ω	DCLK_C		429.8
D_CN(11)	G27	Input	LVC MOS	DDR	Differentially terminated – 100Ω	DCLK_C		317.1
D_CN(12)	D26	Input	LVC MOS	DDR	Differentially terminated – 100Ω	DCLK_C		276.76
D_CN(13)	H28	Input	LVC MOS	DDR	Differentially terminated – 100Ω	DCLK_C		186.78
D_CN(14)	E29	Input	LVC MOS	DDR	Differentially terminated – 100Ω	DCLK_C		311.3
D_CN(15)	J29	Input	LVC MOS	DDR	Differentially terminated – 100Ω	DCLK_C		262.62
D_CP(0)	B16	Input	LVC MOS	DDR	Differentially terminated – 100Ω	DCLK_C		463.64
D_CP(1)	E17	Input	LVC MOS	DDR	Differentially terminated – 100Ω	DCLK_C		347.65
D_CP(2)	A15	Input	LVC MOS	DDR	Differentially terminated – 100Ω	DCLK_C		456.45
D_CP(3)	H20	Input	LVC MOS	DDR	Differentially terminated – 100Ω	DCLK_C		67.72
D_CP(4)	B22	Input	LVC MOS	DDR	Differentially terminated – 100Ω	DCLK_C	362.76	
D_CP(5)	F22	Input	LVC MOS	DDR	Differentially terminated – 100Ω	DCLK_C	161.69	

PIN <sup>(1)</sup>		TYPE (I/O/P)	SIGNAL	DATA RATE <sup>(2)</sup>	INTERNAL TERM <sup>(3)</sup>	CLOCK	DESCRIPTION	TRACE (MILS)	
NAME	NO.								
D_CP(6)	D20	Input	LVC MOS	DDR	Differentially terminated – 100Ω	DCLK_C	Input data bus C (2x LVDS)	195.09	
D_CP(7)	H22	Input	LVC MOS	DDR	Differentially terminated – 100Ω	DCLK_C		104.86	
D_CP(8)	B28	Input	LVC MOS	DDR	Differentially terminated – 100Ω	DCLK_C		451.41	
D_CP(9)	F26	Input	LVC MOS	DDR	Differentially terminated – 100Ω	DCLK_C		294.22	
D_CP(10)	C27	Input	LVC MOS	DDR	Differentially terminated – 100Ω	DCLK_C		429.68	
D_CP(11)	G29	Input	LVC MOS	DDR	Differentially terminated – 100Ω	DCLK_C		314.98	
D_CP(12)	D28	Input	LVC MOS	DDR	Differentially terminated – 100Ω	DCLK_C		276.04	
D_CP(13)	H26	Input	LVC MOS	DDR	Differentially terminated – 100Ω	DCLK_C		186.25	
D_CP(14)	E27	Input	LVC MOS	DDR	Differentially terminated – 100Ω	DCLK_C		312.07	
D_CP(15)	J27	Input	LVC MOS	DDR	Differentially terminated – 100Ω	DCLK_C		262.94	
<b>DATA BUS D</b>									
D_DN(0)	AK14	Input	LVC MOS	DDR	Differentially terminated – 100Ω	DCLK_D		Input data bus D (2x LVDS)	492.53
D_DN(1)	AG15	Input	LVC MOS	DDR	Differentially terminated – 100Ω	DCLK_D			342.78
D_DN(2)	AL17	Input	LVC MOS	DDR	Differentially terminated – 100Ω	DCLK_D			491.83
D_DN(3)	AE21	Input	LVC MOS	DDR	Differentially terminated – 100Ω	DCLK_D			74.24
D_DN(4)	AK20	Input	LVC MOS	DDR	Differentially terminated – 100Ω	DCLK_D	356.23		
D_DN(5)	AF20	Input	LVC MOS	DDR	Differentially terminated – 100Ω	DCLK_D	163.07		
D_DN(6)	AH22	Input	LVC MOS	DDR	Differentially terminated – 100Ω	DCLK_D	204.16		
D_DN(7)	AE23	Input	LVC MOS	DDR	Differentially terminated – 100Ω	DCLK_D	105.59		
D_DN(8)	AK26	Input	LVC MOS	DDR	Differentially terminated – 100Ω	DCLK_D	450.51		
D_DN(9)	AF28	Input	LVC MOS	DDR	Differentially terminated – 100Ω	DCLK_D	302.04		
D_DN(10)	AJ29	Input	LVC MOS	DDR	Differentially terminated – 100Ω	DCLK_D	429.8		
D_DN(11)	AE27	Input	LVC MOS	DDR	Differentially terminated – 100Ω	DCLK_D	298.87		

PIN <sup>(1)</sup>		TYPE (I/O/P)	SIGNAL	DATA RATE <sup>(2)</sup>	INTERNAL TERM <sup>(3)</sup>	CLOCK	DESCRIPTION	TRACE (MILS)
NAME	NO.							
D_DN(12)	AH26	Input	LVC MOS	DDR	Differentially terminated – 100Ω	DCLK_D	Input data bus D (2x LVDS)	276.76
D_DN(13)	AD28	Input	LVC MOS	DDR	Differentially terminated – 100Ω	DCLK_D		186.78
D_DN(14)	AG29	Input	LVC MOS	DDR	Differentially terminated – 100Ω	DCLK_D		311.3
D_DN(15)	AC29	Input	LVC MOS	DDR	Differentially terminated – 100Ω	DCLK_D		262.62
D_DP(0)	AK16	Input	LVC MOS	DDR	Differentially terminated – 100Ω	DCLK_D		495.13
D_DP(1)	AG17	Input	LVC MOS	DDR	Differentially terminated – 100Ω	DCLK_D		342.47
D_DP(2)	AL15	Input	LVC MOS	DDR	Differentially terminated – 100Ω	DCLK_D		492.06
D_DP(3)	AD20	Input	LVC MOS	DDR	Differentially terminated – 100Ω	DCLK_D		67.72
D_DP(4)	AK22	Input	LVC MOS	DDR	Differentially terminated – 100Ω	DCLK_D		356.37
D_DP(5)	AF22	Input	LVC MOS	DDR	Differentially terminated – 100Ω	DCLK_D		161.98
D_DP(6)	AH20	Input	LVC MOS	DDR	Differentially terminated – 100Ω	DCLK_D		195.09
D_DP(7)	AD22	Input	LVC MOS	DDR	Differentially terminated – 100Ω	DCLK_D		102.86
D_DP(8)	AK28	Input	LVC MOS	DDR	Differentially terminated – 100Ω	DCLK_D		451.41
D_DP(9)	AF26	Input	LVC MOS	DDR	Differentially terminated – 100Ω	DCLK_D		296.7
D_DP(10)	AJ27	Input	LVC MOS	DDR	Differentially terminated – 100Ω	DCLK_D		429.68
D_DP(11)	AE29	Input	LVC MOS	DDR	Differentially terminated – 100Ω	DCLK_D		302.74
D_DP(12)	AH28	Input	LVC MOS	DDR	Differentially terminated – 100Ω	DCLK_D	276.04	
D_DP(13)	AD26	Input	LVC MOS	DDR	Differentially terminated – 100Ω	DCLK_D	186.25	
D_DP(14)	AG27	Input	LVC MOS	DDR	Differentially terminated – 100Ω	DCLK_D	312.07	
D_DP(15)	AC27	Input	LVC MOS	DDR	Differentially terminated – 100Ω	DCLK_D	262.94	



PIN <sup>(1)</sup>		TYPE (I/O/P)	SIGNAL	DATA RATE <sup>(2)</sup>	INTERNAL TERM <sup>(3)</sup>	CLOCK	DESCRIPTION	TRACE (MILS)
NAME	NO.							
<b>DATA CLOCKS</b>								
DCLK_AN	D10	Input	LVC MOS	—	Differentially terminated – 100Ω	—	Input data bus A Clock (2x LVDS)	325.8
DCLK_AP	D8	Input	LVC MOS	—	Differentially terminated – 100Ω	—		319.9
DCLK_BN	AJ11	Input	LVC MOS	—	Differentially terminated – 100Ω	—	Input data bus B Clock (2x LVDS)	318.92
DCLK_BP	AJ9	Input	LVC MOS	—	Differentially terminated – 100Ω	—		318.74
DCLK_CN	C23	Input	LVC MOS	—	Differentially terminated – 100Ω	—	Input data bus C Clock (2x LVDS)	252.01
DCLK_CP	C21	Input	LVC MOS	—	Differentially terminated – 100Ω	—		241.18
DCLK_DN	AJ23	Input	LVC MOS	—	Differentially terminated – 100Ω	—	Input data bus D Clock (2x LVDS)	252.01
DCLK_DP	AJ21	Input	LVC MOS	—	Differentially terminated – 100Ω	—		241.18
<b>DATA CONTROL INPUTS</b>								
SCTRL_AN	J3	Input	LVC MOS	DDR	Differentially terminated – 100Ω	DCLK_A	Serial control for data bus A (2x LVDS)	608.14
SCTRL_AP	J5	Input	LVC MOS	DDR	Differentially terminated – 100Ω	DCLK_A		607.45
SCTRL_BN	AF4	Input	LVC MOS	DDR	Differentially terminated – 100Ω	DCLK_B	Serial control for data bus B (2x LVDS)	698.12
SCTRL_BP	AF2	Input	LVC MOS	DDR	Differentially terminated – 100Ω	DCLK_B		703.8
SCTRL_CN	E23	Input	LVC MOS	DDR	Differentially terminated – 100Ω	DCLK_C	Serial control for data bus C (2x LVDS)	232.46
SCTRL_CP	E21	Input	LVC MOS	DDR	Differentially terminated – 100Ω	DCLK_C		235.21
SCTRL_DN	AG23	Input	LVC MOS	DDR	Differentially terminated – 100Ω	DCLK_D	Serial control for data bus D (2x LVDS)	235.53
SCTRL_DP	AG21	Input	LVC MOS	DDR	Differentially terminated – 100Ω	DCLK_D		235.66
<b>SERIAL COMMUNICATION AND CONFIGURATION</b>								
SCPCLK	AE1	Input	LVC MOS	—	pull down	—	Serial port clock	324.26
SCPDO	AC3	Output	LVC MOS	—	—	SCP_CLK	Serial port output	281.38
SCPDI	AD2	Input	LVC MOS	—	pull down	SCP_CLK	Serial port input	261.55
SCPEN	AD4	Input	LVC MOS	—	pull down	SCP_CLK	Serial port enable	184.86
PWRDN	B4	Input	LVC MOS	—	pull down	—	Device reset	458.78
MODE_A	J1	Input	LVC MOS	—	pull down	—	Data bandwidth mode select	471.57
MODE_B	G1	Input	LVC MOS	—	pull down	—		521.99

PIN <sup>(1)</sup>		TYPE (I/O/P)	SIGNAL	DATA RATE <sup>(2)</sup>	INTERNAL TERM <sup>(3)</sup>	CLOCK	DESCRIPTION	TRACE (MILS)
NAME	NO.							
<b>MICROMIRROR CLOCKING PULSE (BIAS RESET)</b>								
MBRST(0)	L5	Input	Analog	—	—	—	Micromirror clocking pulse reset MBRST signals clock micromirrors into state of LVCMOS memory cell associated with each mirror.	898.97
MBRST(1)	M28	Input	Analog	—	—	—		621.98
MBRST(2)	P4	Input	Analog	—	—	—		846.88
MBRST(3)	P30	Input	Analog	—	—	—		784.18
MBRST(4)	L3	Input	Analog	—	—	—		763.34
MBRST(5)	P28	Input	Analog	—	—	—		749.61
MBRST(6)	P2	Input	Analog	—	—	—		878.25
MBRST(7)	T28	Input	Analog	—	—	—		783.83
MBRST(8)	M4	Input	Analog	—	—	—		969.36
MBRST(9)	L29	Input	Analog	—	—	—		621.24
MBRST(10)	T4	Input	Analog	—	—	—		918.43
MBRST(11)	N29	Input	Analog	—	—	—		685.14
MBRST(12)	N3	Input	Analog	—	—	—		812.31
MBRST(13)	L27	Input	Analog	—	—	—		591.89
MBRST(14)	R3	Input	Analog	—	—	—		878.5
MBRST(15)	V28	Input	Analog	—	—	—		660.15
MBRST(16)	V4	Input	Analog	—	—	—		848.64
MBRST(17)	R29	Input	Analog	—	—	—		796.31
MBRST(18)	Y4	Input	Analog	—	—	—		715
MBRST(19)	AA27	Input	Analog	—	—	—		604.35
MBRST(20)	W3	Input	Analog	—	—	—		832.39
MBRST(21)	W27	Input	Analog	—	—	—		675.21
MBRST(22)	AA3	Input	Analog	—	—	—		861.18
MBRST(23)	W29	Input	Analog	—	—	—		662.66
MBRST(24)	U5	Input	Analog	—	—	—		850.06
MBRST(25)	U29	Input	Analog	—	—	—		726.56
MBRST(26)	Y2	Input	Analog	—	—	—		861.48
MBRST(27)	AA29	Input	Analog	—	—	—		683.83
MBRST(28)	U3	Input	Analog	—	—	—		878.5
MBRST(29)	Y30	Input	Analog	—	—	—		789.2

PIN <sup>(1)</sup>		TYPE (I/O/P)	SIGNAL	DATA RATE <sup>(2)</sup>	INTERNAL TERM <sup>(3)</sup>	CLOCK	DESCRIPTION	TRACE (MILS)
NAME	NO.							
<b>POWER</b>								
VCC	A3, A5, A7, A9, A11, A13, A21, A23, A25, A27, A29, B2,	Power	Analog	—	—	—	Power for LVCMOS logic	—
	C1, C31, E31, G31, J31, K2, L31, N31, R31, U31, W31,							
	AA31, AC1, AC31, AE31, AG1, AG31, AJ31, AK2,							
	AK30, AL3, AL5, AL7, AL19, AL21, AL23, AL25, AL27							
VCCI	H6, H12, H18, H24, M6, M26, P6, P26, T6, T26, V6, V26, Y6, Y26, AD6, AD12, AD18, AD24	Power	Analog	—	—	—	Power supply for LVDS Interface	—
VCC2	L1, N1, R1, U1, W1, AA1	Power	Analog	—	—	—	Power for high voltage CMOS logic	—
VSS	A1, B12, B18, B24, B30, C7, C13, C19, C25, D6, D12,  D18, D24, D30, E1, E7, E13, E19, E25, F6, F12, F18, F24,  F30, G7, G13, G19, G25, K4, K6, K26, K28, K30, M2, M30,  N5, N27, R5, T2, T30, U27, V2, V30, W5, Y28, AB2, AB4,  AB6, AB26, AB28, AB30, AD30, AE7, AE13, AE19,  AE25, AF6, AF12, AF18, AF24, AF30, AG7, AG13,  AG19, AG25, AH6, AH12, AH18, AH24, AH30, AJ1,  AJ7, AJ13, AJ19, AJ25, AK6, AK12, AK18, AL29	Power	Analog	—	—	—	Common return for all power inputs	—

PIN <sup>(1)</sup>		TYPE (I/O/P)	SIGNAL	DATA RATE <sup>(2)</sup>	INTERNAL TERM <sup>(3)</sup>	CLOCK	DESCRIPTION	TRACE (MILS)
NAME	NO.							
<b>RESERVED SIGNALS (NOT FOR USE IN SYSTEM)</b>								
RESERVED_FC	J7	Input	LVC MOS	—	pulldown	—	Pins should be connected to VSS	—
RESERVED_FD	J9	Input	LVC MOS	—	pulldown	—		—
RESERVED_PFE	J11	Input	LVC MOS	—	pulldown	—		—
RESERVED_STM	AC7	Input	LVC MOS	—	pulldown	—		—
RESERVED_AE	C3	Input	LVC MOS	—	pulldown	—		—
NO_CONNECT	A19, B6, C5, H30, J13, J15, J17, J19, J21, J23, J25, R27, AA5, AC11, AC13, AC15, AC17, AC19, AC21, AC23, AC25, AC5, AC9, AK24, AK4, AL13	—	—	—	—	—	No connection (any connection to these terminals may result in undesirable effects)	—

- (1) The following power supplies are required to operate the DMD: VCC, VCC1, VCC2. VSS must also be connected.
- (2) DDR = Double Data Rate. SDR = Single Data Rate. Refer to the [Section 6.7](#) for specifications and relationships.
- (3) Refer to [Section 6.6](#) for differential termination specification.

## 6 Specifications

### 6.1 Absolute Maximum Ratings

over operating free-air temperature (unless otherwise noted). <sup>(1)</sup>

		MIN	MAX	UNIT
<b>ELECTRICAL</b>				
V <sub>CC</sub>	Voltage applied to V <sub>CC</sub> <sup>(2) (3)</sup>	-0.5	4	V
V <sub>CCI</sub>	Voltage applied to V <sub>CCI</sub> <sup>(2) (3)</sup>	-0.5	4	V
V <sub>CC2</sub>	Voltage applied to V <sub>CC2</sub> <sup>(2) (3) (4)</sup>	-0.5	9	V
V <sub>MBRST</sub>	Clocking pulse waveform voltage applied to MBRST[29:0] input pins (supplied by DLPA200s)	-28	28	V
V <sub>CC</sub> - V <sub>CCI</sub>	Supply voltage delta (absolute value) <sup>(4)</sup>		0.3	V
	Voltage applied to all other input terminals <sup>(2)</sup>	-0.5	V <sub>CC</sub> + 0.3	V
V <sub>ID</sub>	Maximum differential voltage, damage can occur to internal termination resistor if exceeded, see <a href="#">Figure 6-2</a>		700	mV
	Current required from a high-level output, V <sub>OH</sub> = 2.4V		-20	mA
	Current required from a low-level output, V <sub>OL</sub> = 0.4V		15	mA
<b>ENVIRONMENTAL</b>				
T <sub>ARRAY</sub>	Array temperature – operational <sup>(5)</sup>	20	30	°C
	Array temperature – non-operational <sup>(5)</sup>	-40	80	°C
T <sub>DELTA</sub>	Absolute temperature delta between the window test points (TP2, TP3) and the ceramic test point TP1 <sup>(6)</sup>		10	°C
RH	Relative humidity (non-condensing)		95%	—

- (1) Operation outside the Absolute Maximum Ratings may cause permanent device damage. Absolute Maximum Ratings do not imply functional operation of the device at these or any other conditions beyond those listed under Recommended Operating Conditions. If outside the Recommended Operating Conditions but within the Absolute Maximum Ratings, the device may not be fully functional, and this may affect device reliability, functionality, performance, and shorten the device lifetime.
- (2) All voltages referenced to V<sub>SS</sub> (ground)
- (3) Voltages V<sub>CC</sub>, V<sub>CCI</sub>, and V<sub>CC2</sub> are required for proper DMD operation.
- (4) Exceeding the recommended allowable absolute voltage difference between V<sub>CC</sub> and V<sub>CCI</sub> may result in excess current draw. The difference between V<sub>CC</sub> and V<sub>CCI</sub>, |V<sub>CC</sub> - V<sub>CCI</sub>|, should be less than the specified limit.
- (5) The worst-case temperature of any test point shown in *Thermal Test Point Locations*, or the active array as calculated by the micromirror array temperature calculation.
- (6) As either measured, predicted, or both between any two points - measured on the exterior of the package, or as predicted at any point inside the micromirror array cavity. Refer to the micromirror array temperature calculation.

### 6.2 Storage Conditions

Applicable for the DMD as a component or non-operating in a system

		MIN	MAX	UNIT
T <sub>DMD</sub>	Storage temperature	-40	80	°C
RH	Storage humidity (non-condensing)		95	%

### 6.3 ESD Ratings

			VALUE	UNIT
V <sub>ESD</sub>	Electrostatic discharge	Human body model (HBM), per ANSI/ESDA/JEDEC JS-001 <sup>(1)</sup>	±2000	V
		All pins except MBRST[29:0]	±250	
		MBRST[29:0] pins		

- (1) JEDEC document JEP155 states that 500V HBM allows safe manufacturing with a standard ESD control process. Manufacturing with less than 500V HBM is possible if necessary precautions are taken.

## 6.4 Recommended Operating Conditions

over operating free-air temperature range (unless otherwise noted)<sup>(1)</sup>

		MIN	NOM	MAX	UNIT
<b>ELECTRICAL</b>					
V <sub>CC</sub>	Supply voltage for LVCMOS core logic <sup>(2) (3)</sup>	3.0	3.3	3.6	V
V <sub>CCI</sub>	Supply voltage for LVDS receivers <sup>(2) (3)</sup>	3.0	3.3	3.6	V
V <sub>CC2</sub>	Mirror electrode and HVCMOS supply voltage <sup>(2) (3)</sup>	8.25	8.5	8.75	V
V <sub>MBRST</sub>	Clocking pulse waveform voltage applied to MBRST[15:0] input pins (supplied by DLPA200)	-27		26.5	V
<b>MECHANICAL</b>					
	Static load applied to electrical interface area, see <sup>(4)</sup> Figure 6-5			1334	N
	Static load applied to the thermal interface area, see <sup>(5)</sup> Figure 6-5			156	N
	Static load applied to Datum 'A' interface area Figure 6-5			712	N
<b>ENVIRONMENTAL <sup>(6)</sup></b>					
	Illumination power density <sup>(4) (12)</sup>	< 363nm <sup>(7)</sup>		2	mW/cm <sup>2</sup>
		363 to 400nm <sup>(8)</sup>		5.2	W/cm <sup>2</sup>
		400 to 420nm <sup>(8)</sup>		12.5	W
		400 to 420nm <sup>(8)</sup>		11	W/cm <sup>2</sup>
		400 to 420nm <sup>(8)</sup>		26.6	W
		363 to 420nm total <sup>(8) (9)</sup>		11	W/cm <sup>2</sup>
		363 to 420nm total <sup>(8) (9)</sup>		26.6	W
	> 420nm	Thermally limited <sup>(8)</sup>			W/cm <sup>2</sup>
T <sub>C</sub>	Case/array temperature <sup>(10) (11)</sup>	20	30 <sup>(12)</sup>		°C
T <sub>GRADIENT</sub>	Device temperature gradient – operational <sup>(13)</sup>		10		°C
RH	Relative humidity (non-condensing) <sup>(14)</sup>		95		%RH
	Operating landed duty cycle <sup>(15)</sup>		25%		

- (1) The functional performance of the device specified in this data sheet is achieved when operating the device within the limits defined by the Recommended Operating Conditions. No level of performance is implied when operating the device above or below the Recommended Operating Conditions limits.
- (2) All voltages referenced to VSS (ground).
- (3) Voltages V<sub>CC</sub>, V<sub>CC2</sub>, and V<sub>CCI</sub>, are required for proper DMD operation. VSS must also be connected.
- (4) Load should be uniformly distributed across the entire electrical interface area.
- (5) Load should be uniformly distributed across the thermal interface area. Refer to Figure 6-5.
- (6) Optimal, long-term performance and optical efficiency of the Digital Micromirror Device (DMD) can be affected by various application parameters, including illumination spectrum, illumination power density, micromirror landed duty-cycle, ambient temperature (storage and operating), DMD temperature, ambient humidity (storage and operating), and power on or off duty cycle. TI recommends that application-specific effects be considered as early as possible in the design cycle.
- (7) The maximum operating conditions for operating temperature and illumination power density for wavelengths < 363nm should not be implemented simultaneously.
- (8) Also limited by the resulting micromirror array temperature. Refer to Case Temperature and Micromirror Array Temperature Calculation for information related to calculating the micromirror array temperature.
- (9) The total integrated illumination power density from 363 to 420nm shall not exceed 11 W/cm<sup>2</sup> (or 26.6 W evenly distributed on the active array area). Therefore if 2.5 W/cm<sup>2</sup> of illumination is used in the 363 to 400nm range, then illumination in the 400 to 420nm range must be limited to 8.5 W/cm<sup>2</sup>.
- (10) In some applications, the total DMD heat load can be dominated by the amount of incident light energy absorbed. See Micromirror Array Temperature Calculation for further details.
- (11) Temperature is the highest measured value of any test point shown in Figure 18 or the active array as calculated by the Micromirror Array Temperature Calculation.
- (12) See the Micromirror Array Temperature Calculation for thermal test point locations, package thermal resistance, and device temperature calculation.
- (13) As either measured, predicted, or both between any two points - measured on the exterior of the package, or as predicted at any point inside the micromirror array cavity. Refer to Case Temperature and Micromirror Array Temperature Calculation.
- (14) Various application parameters can affect the optimal, long-term performance of the DMD, including illumination spectrum, illumination power density, micromirror landed duty cycle, ambient temperature (both storage and operating), case temperature, and power-on or power-off duty cycle. TI recommends that application-specific effects be considered as early as possible in the design cycle. Contact your local TI representative for additional information related to optimizing the DMD performance.
- (15) Landed duty cycle refers to the percentage of time an individual micromirror spends landed in one state (12° or -12°) versus the other state (-12° or 12°).

## 6.5 Thermal Information

THERMAL METRIC <sup>(1)</sup>	DLP9500UV	UNIT
	FLN (LCCC)	
	355 PINS	
Thermal resistance, active area to test point 1 (TP1)	0.5	°C/W

- (1) For more information about traditional and new thermal metrics, see the Semiconductor and IC Package Thermal Metrics application report, [SPRA953](#).

## 6.6 Electrical Characteristics

over the range of recommended supply voltage and recommended case operating temperature (unless otherwise noted); under recommended operating conditions

PARAMETER		TEST CONDITIONS	MIN	TYP	MAX	UNIT
V <sub>OH</sub>	High-level output voltage <sup>(1)</sup> , See <a href="#">Figure 7-4</a>	V <sub>CC</sub> = 3V, I <sub>OH</sub> = –20mA	2.4			V
V <sub>OL</sub>	Low-level output voltage <sup>(1)</sup> , See <a href="#">Figure 7-4</a>	V <sub>CC</sub> = 3.6V, I <sub>OH</sub> = 15mA			0.4	V
V <sub>MBRST</sub>	Clocking pulse waveform applied to MBRST[29:0] input pins (supplied by DLPA200s)		–27		26.5	V
I <sub>OZ</sub>	High-impedance output current <sup>(1)</sup>	V <sub>CC</sub> = 3.6V			10	μA
I <sub>OH</sub>	High-level output current <sup>(1)</sup>	V <sub>OH</sub> = 2.4V, V <sub>CC</sub> ≥ 3V			–20	mA
		V <sub>OH</sub> = 1.7V, V <sub>CC</sub> ≥ 2.25V			–15	mA
I <sub>OL</sub>	Low-level output current <sup>(1)</sup>	V <sub>OL</sub> = 0.4V, V <sub>CC</sub> ≥ 3V			15	mA
		V <sub>OL</sub> = 0.4V, V <sub>CC</sub> ≥ 2.25V			14	mA
V <sub>IH</sub>	High-level input voltage <sup>(1)</sup>		1.7		V <sub>CC</sub> + 0.3	V
V <sub>IL</sub>	Low-level input voltage <sup>(1)</sup>		–0.3		0.7	V
I <sub>IL</sub>	Low-level input current <sup>(1)</sup>	V <sub>CC</sub> = 3.6V, V <sub>I</sub> = 0V			–60	μA
I <sub>IH</sub>	High-level input current <sup>(1)</sup>	V <sub>CC</sub> = 3.6V, V <sub>I</sub> = V <sub>CC</sub>			60	μA
I <sub>CC</sub>	Current into V <sub>CC</sub> pin	V <sub>CC</sub> = 3.6V,			2990	mA
I <sub>CCI</sub>	Current into V <sub>OFFSET</sub> pin <sup>(2)</sup>	V <sub>CCI</sub> = 3.6V			910	mA
I <sub>CC2</sub>	Current into V <sub>CC2</sub> pin	V <sub>CC2</sub> = 8.75V			25	mA
P <sub>D</sub>	Power dissipation		4.4			W
Z <sub>IN</sub>	Internal differential impedance		95		105	Ω
Z <sub>LINE</sub>	Line differential impedance (PWB, trace)		90	100	110	Ω
C <sub>I</sub>	Input capacitance <sup>(1)</sup>	f = 1MHz			10	pF
C <sub>O</sub>	Output capacitance <sup>(1)</sup>	f = 1MHz			10	pF
C <sub>IM</sub>	Input capacitance for MBRST[29:0] pins	f = 1MHz	270		355	pF

(1) Applies to LVCMOS pins only.

(2) Exceeding the maximum allowable absolute voltage difference between V<sub>CC</sub> and V<sub>CCI</sub> may result in excess current draw (See [Section 6.1](#) for details).



## 6.7 LVDS Timing Requirements

over operating free-air temperature range (unless otherwise noted); see [Figure 6-1](#)

		MIN	NOM	MAX	UNIT
$f_{DCLK\_x}$	DCLK_x clock frequency (where x = [A, B, C, or D])	200		400	MHz
$t_c$	Clock cycle - DLCK_x	2.5			ns
$t_w$	Pulse duration - DLCK_x		1.25		ns
$t_s$	Setup time - D_x[15:0] and SCTRL_x before DCLK_x	0.35			ns
$t_h$	Hold time, D_x[15:0] and SCTRL_x after DCLK_x	0.35			ns
$t_{skew}$	Skew between any two buses (A, B, C, and D)	-1.25		1.25	ns

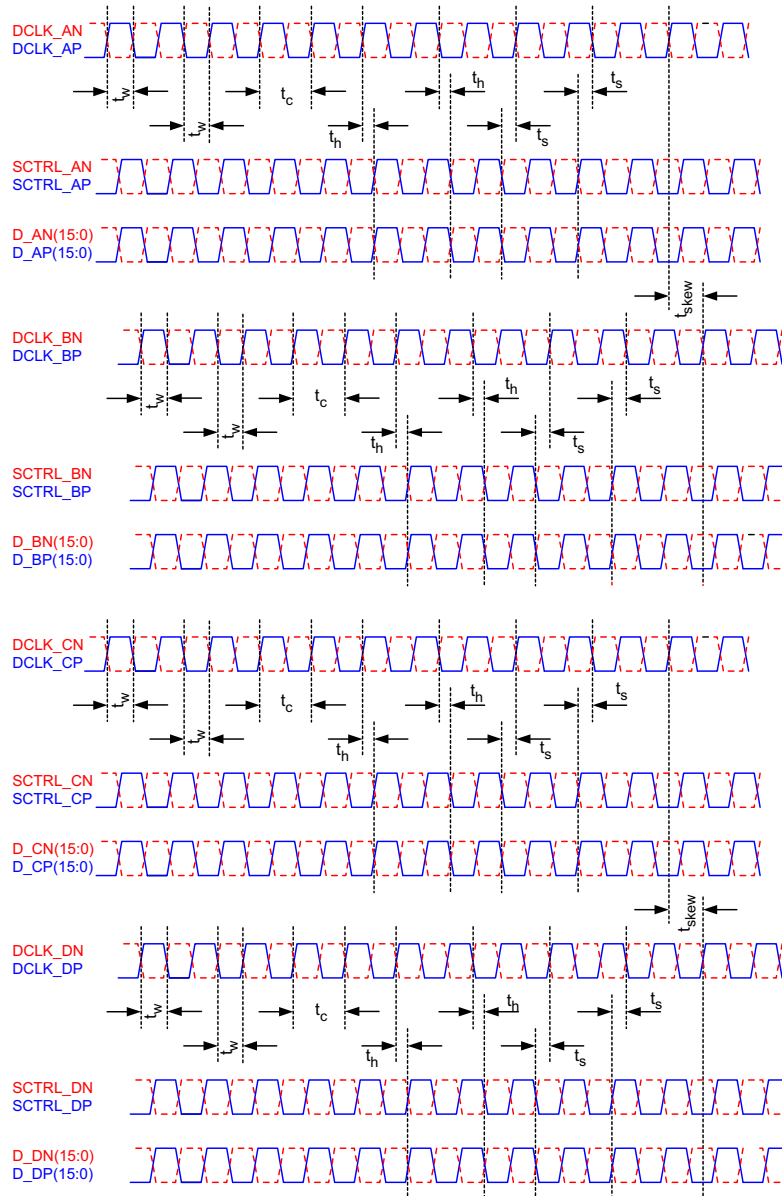
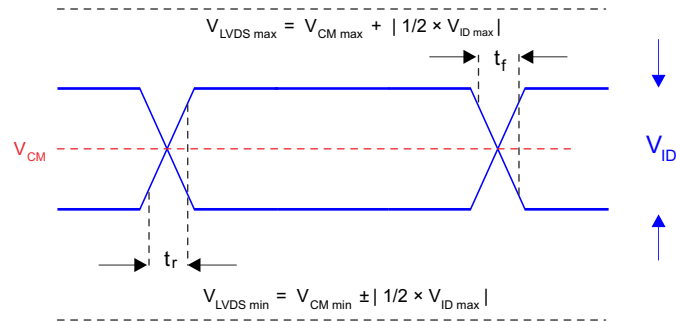

Figure 6-1. LVDS Timing Waveforms

## 6.8 LVDS Waveform Requirements

over operating free-air temperature range (unless otherwise noted); see [Figure 6-2](#)

		MIN	NOM	MAX	UNIT
$ V_{ID} $	Input differential voltage (absolute difference)	100	400	600	mV
$V_{CM}$	Common mode voltage		1200		mV
$V_{LVDS}$	LVDS voltage	0		2000	mV
$t_r$	Rise time (20% to 80%)	100		400	ps
$t_f$	Fall time (80% to 20%)	100		400	ps



**Figure 6-2. LVDS Waveform Requirements**

### 6.9 Serial Control Bus Timing Requirements

over operating free-air temperature range (unless otherwise noted); see [Figure 6-3](#) and [Figure 6-4](#)

		MIN	NOM	MAX	UNIT
$f_{SCP\_CLK}$	SCP clock frequency	50		500	kHz
$t_{SCP\_SKEW}$	Time between valid SCP_DI and rising edge of SCP_CLK	-300		300	ns
$t_{SCP\_DELAY}$	Time between valid SCP_DO and rising edge of SCP_CLK			960	ns
$t_{SCP\_EN}$	Time between falling edge of $\overline{SCP\_EN}$ and the first rising edge of SCP_CLK	30			ns
$t_{SCP}$	Rise time for SCP signals			200	ns
$t_{f\_SCP}$	Fall time for SCP signals			200	ns

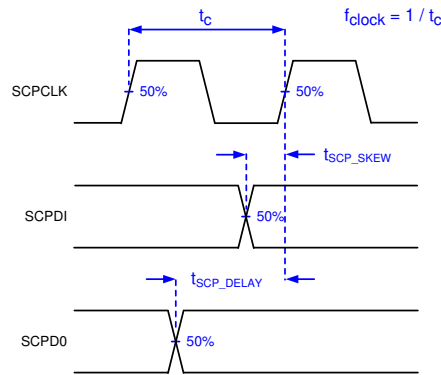

Figure 6-3. Serial Communications Bus Timing Parameters

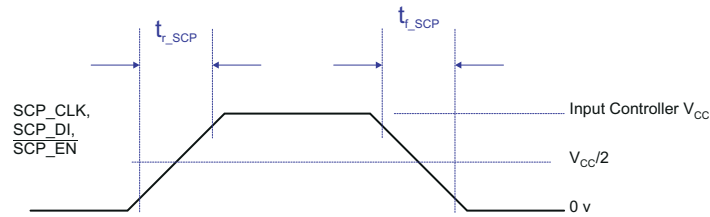
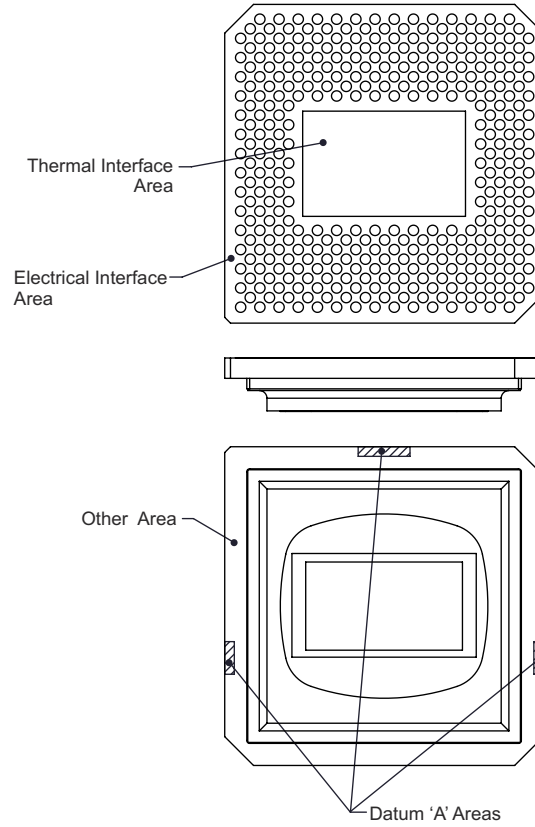

Figure 6-4. Serial Communications Bus Waveform Requirements

### 6.10 Systems Mounting Interface Loads

	PARAMETER	MIN	NOM	MAX	UNIT
Maximum system mounting interface load to be applied to the:	Thermal interface area (see <a href="#">Figure 6-5</a> )			156	N
	Electrical interface area (see <a href="#">Figure 6-5</a> )			1334	N
	Datum A Interface area (see <a href="#">Figure 6-5</a> )			712	N



**Figure 6-5. System Interface Loads**

### 6.11 Micromirror Array Physical Characteristics

See [Mechanical, Packaging, and Orderable Information](#) for additional details.

		VALUE	UNIT
M	Number of active micromirror columns <sup>(1)</sup>	1920	micromirrors
N	Number of active micromirror rows <sup>(1)</sup>	1080	micromirrors
P	Micromirror (pixel) pitch <sup>(1)</sup>	10.8	μm
	Micromirror active array width <sup>(1)</sup>	M × P	mm
	Micromirror active array height <sup>(1)</sup>	N × P	mm
	Micromirror array border <sup>(1) (2)</sup>	Pond of micromirrors (POM)	10 micromirrors/side

- (1) See [Figure 6-6](#).
- (2) The structure and qualities of the border around the active array includes a band of partially functional micromirrors called the POM. These micromirrors are structurally and/or electrically prevented from tilting toward the bright or ON state, but still require an electrical bias to tilt toward OFF.

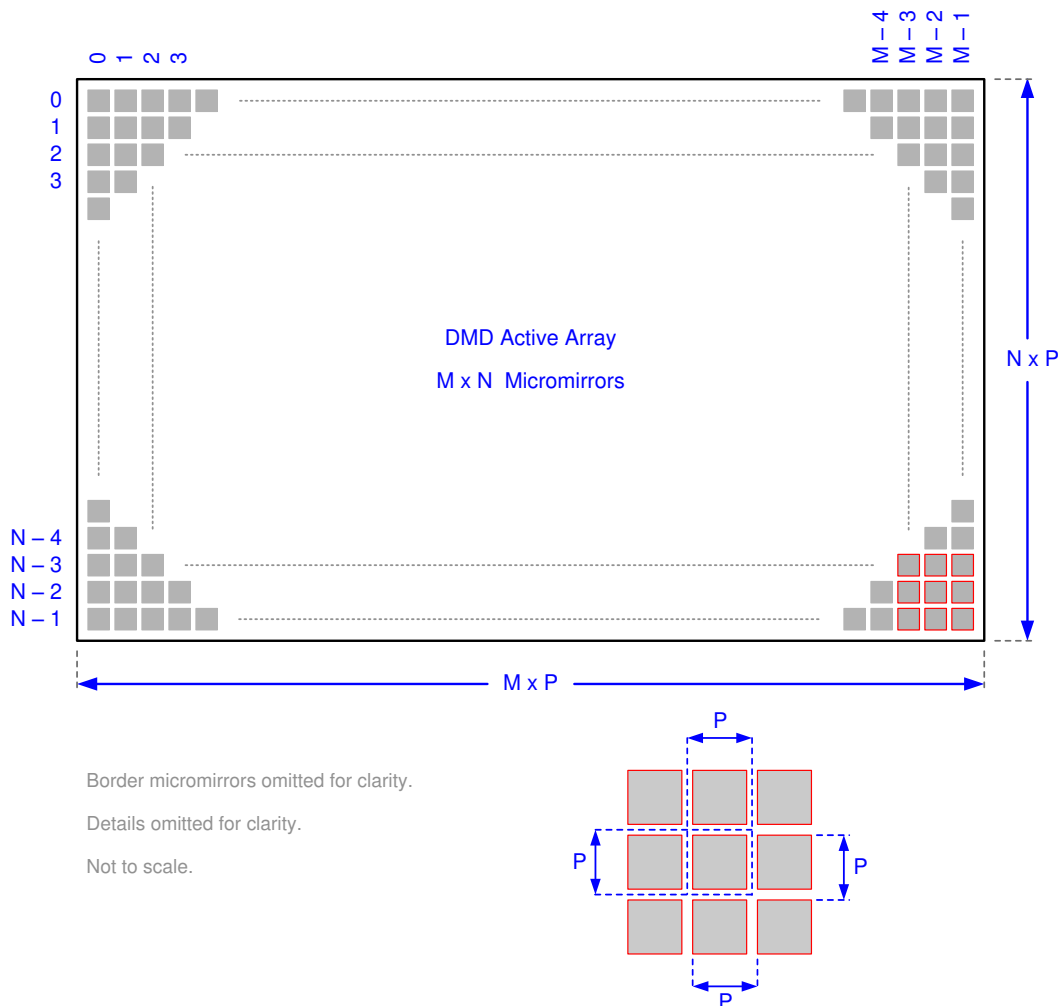

Refer to the [Section 6.11](#) table for M, N, and P specifications.

**Figure 6-6. Micromirror Array Physical Characteristics**

## 6.12 Micromirror Array Optical Characteristics

TI assumes no responsibility for end-equipment optical performance. Achieving the desired end-equipment optical performance involves making trade-offs between numerous component and system design parameters. See the related application reports (listed in [Related Links](#)) for guidelines.

PARAMETER		TEST CONDITIONS	MIN	NOM	MAX	UNIT
a	Micromirror tilt angle	DMD parked state <sup>(1) (2) (3)</sup> , See <a href="#">Figure 7-6</a>			0	degrees
		DMD landed state <sup>(1) (4) (5)</sup> See <a href="#">Figure 7-6</a>			12	
$\beta$	Micromirror tilt angle variation <sup>(1) (4) (6) (7) (8)</sup>	See <a href="#">Figure 7-6</a>	-1		1	degrees
		Micromirror crossover time <sup>(9)</sup>		3		$\mu$ s
		Micromirror switching time <sup>(10)</sup>		12.5		$\mu$ s
		Array switching time at 400MHz with global reset <sup>(11)</sup>		56		$\mu$ s
	Non-operating micromirrors <sup>(12)</sup>	Non-adjacent micromirrors			10	micromirrors
		Adjacent micromirrors			0	
	Orientation of the micromirror axis-of-rotation <sup>(13)</sup>	See <a href="#">Figure 7-6</a>	44	45	46	degrees
	Micromirror array optical efficiency <sup>(14) (15)</sup>	363nm to 420nm, with all micromirrors in the ON state		68%		
	Window material			Corning 7056		
	Window artifact size	Within the window aperture <sup>(16)</sup>			400	$\mu$ m
	Window aperture			See <sup>(17)</sup>		

- (1) Measured relative to the plane formed by the overall micromirror array.
- (2) Parking the micromirror array returns all of the micromirrors to an essentially flat (0°) state (as measured relative to the plane formed by the overall micromirror array).
- (3) When the micromirror array is parked, the tilt angle of each individual micromirror is uncontrolled.
- (4) Additional variation exists between the micromirror array and the package datums, as shown in *Mechanical, Packaging, and Orderable Information*.
- (5) When the micromirror array is landed, the tilt angle of each individual micromirror is dictated by the binary contents of the CMOS memory cell associated with each individual micromirror. A binary value of 1 results in a micromirror landing in a nominal angular position of +12°. A binary value of 0 results in a micromirror landing in a nominal angular position of -12°.
- (6) Represents the landed tilt angle variation relative to the nominal landed tilt angle.
- (7) Represents the variation that can occur between any two individual micromirrors, located on the same device or located on different devices.
- (8) For some applications, it is critical to account for the micromirror tilt angle variation in the overall system optical design. With some system optical designs, the micromirror tilt angle variation within a device may result in perceivable non-uniformities in the light field reflected from the micromirror array. With some system optical designs, the micromirror tilt angle variation between devices may result in colorimetry variations and/or system contrast variations.
- (9) Micromirror crossover time is the transition time from landed to landed during a crossover transition and is primarily a function of the natural response time of the micromirrors.
- (10) Micromirror switching time is the time after a micromirror clocking pulse until the micromirrors can be addressed again. It included the micromirror settling time.
- (11) Array switching is controlled and coordinated by the [DLPC410](#) and [DLPA200](#). Nominal switching time depends on the system implementation and represents the time for the entire micromirror array to be refreshed (array loaded plus reset and mirror settling time).
- (12) Non-operating micromirror is defined as a micromirror that is unable to transition nominally from the -12° position to +12° or vice versa.
- (13) Measured relative to the package datums 'B' and 'C', shown in the *Mechanical, Packaging, and Orderable Information*.
- (14) The minimum or maximum DMD optical efficiency observed in a specific application depends on numerous application-specific design variables, such as:
  - Illumination wavelength, bandwidth/line width, degree of coherence
  - Illumination angle, plus angle tolerance
  - Illumination and projection aperture size, and location in the system optical path
  - Illumination overfill of the DMD micromirror array
  - Aberrations present in the illumination source and/or path
  - Aberrations present in the projection path

The specified nominal DMD optical efficiency is based on the following use conditions:

- UV illumination (363nm to 420nm)
- Input illumination optical axis oriented at 24° relative to the window normal
- Projection optical axis oriented at 0° relative to the window normal
- $f / 3.0$  illumination aperture
- $f / 2.4$  projection aperture

Based on these use conditions, the nominal DMD optical efficiency results from the following four components:

- Micromirror array fill factor: nominally 94%
  - Micromirror array diffraction efficiency: nominally 85%
  - Micromirror surface reflectivity: nominally 89%
  - Window transmission: nominally 98% (single pass, through two surface transitions)
- (15) Does not account for the effect of micromirror switching duty cycle, which is application-dependent. The micromirror switching duty cycle represents the percentage of time that the micromirror is actually reflecting light from the optical illumination path to the optical projection path. This duty cycle depends on the illumination aperture size, the projection aperture size, and the micromirror array update rate.
- (16) See *Mechanical, Packaging, and Orderable Information* for details regarding the size and location of the window aperture.
- (17) Refers only to non-cleanable artifacts. See the [DMD S4xx Glass Cleaning Procedure](#) and [DMD S4xx Handling Specifications](#) for recommended handling and cleaning processes.

### 6.13 Chipset Component Usage Specification

The DLP9500UV is a component of one or more DLP chipsets. Reliable function and operation of the DLP9500UV requires that it be used in conjunction with the other components of the applicable DLP chipset, including those components that contain or implement TI DMD control technology. TI DMD control technology is the TI technology and devices for operating or controlling a DLP DMD.

## 7 Detailed Description

### 7.1 Overview

Optically, the DLP9500UV consists of 2,073,600 highly reflective, digitally switchable, micrometer-sized mirrors (micromirrors), organized in a two-dimensional array of 1920 micromirror columns by 1080 micromirror rows. Each aluminum micromirror is approximately 10.8 microns in size (see the *Micromirror Pitch* section) and is switchable between two discrete angular positions:  $-12^\circ$  and  $12^\circ$ . The angular positions are measured relative to a  $0^\circ$  flat state, which is parallel to the array plane (see [Figure 7-6](#) section). The tilt direction is perpendicular to the hinge axis, which is positioned diagonally relative to the overall array. The On State landed position is directed toward row 0, column 0 (upper left) corner of the device package (see the *Micromirror Pitch* section). In the field of visual displays, the  $1920 \times 1080$  pixel resolution is referred to as 1080p.

Each individual micromirror is positioned over a corresponding CMOS memory cell. The angular position of a specific micromirror is determined by the binary state (logic 0 or 1) of the corresponding CMOS memory cell contents after the mirror clocking pulse is applied. The angular position ( $-12^\circ$  or  $+12^\circ$ ) of the individual micromirrors changes synchronously with a micromirror clocking pulse, rather than being synchronous with the CMOS memory cell data update. Therefore, writing logic 1 into a memory cell, followed by a mirror clocking pulse, results in the corresponding micromirror switching to a  $12^\circ$  position. Writing a logic 0 into a memory cell, followed by a mirror clocking pulse, results in the corresponding micromirror switching to a  $-12^\circ$  position.

Updating the angular position of the micromirror array consists of two steps. First, update the contents of the CMOS memory. Second, the application of a micromirror clocking pulse to all or a portion of the micromirror array (depending upon the configuration of the system). Micromirror clocking pulses are generated externally by two DLPA200s, with the application of the pulses being coordinated by the DLPC410 controller.

Around the perimeter of the 1920 by 1080 array of micromirrors is a uniform band of border micromirrors. The border micromirrors are not user-addressable. The border micromirrors land in the  $-12^\circ$  position once power has been applied to the device. There are 10 border micromirrors on each side of the 1920 by 1080 active array.

[Figure 7-1](#) shows a DLPC410 and DLP9500UV chipset block diagram. The DLPC410 and DLPA200s control and coordinate the data loading and micromirror switching for reliable DLP9500UV operation. The DLPR410 is the programmed PROM required to properly configure the DLPC410 controller. For more information on the chipset components, see [Section 8](#). For a typical system application using the DLP Discovery 4100 chipset including a DLP9500UV, see [Figure 8-2](#).

### 7.2 Functional Block Diagram

[Figure 7-1](#) shows a simplified system block diagram with the use of the DLPC410, with the following chipset components:

- DLPC410** Xilinx [XC5VLX30] FPGA configured to provide high-speed DMD data and control, and DLPA200 timing and control
- DLPR410** [XCF16PFSG48C] serial flash PROM contains startup configuration information (EEPROM)
- DLPA200** Two DMD micromirror drivers for the DLP9500UV DMD
- DLP9500UV** Spatial light modulator (DMD)



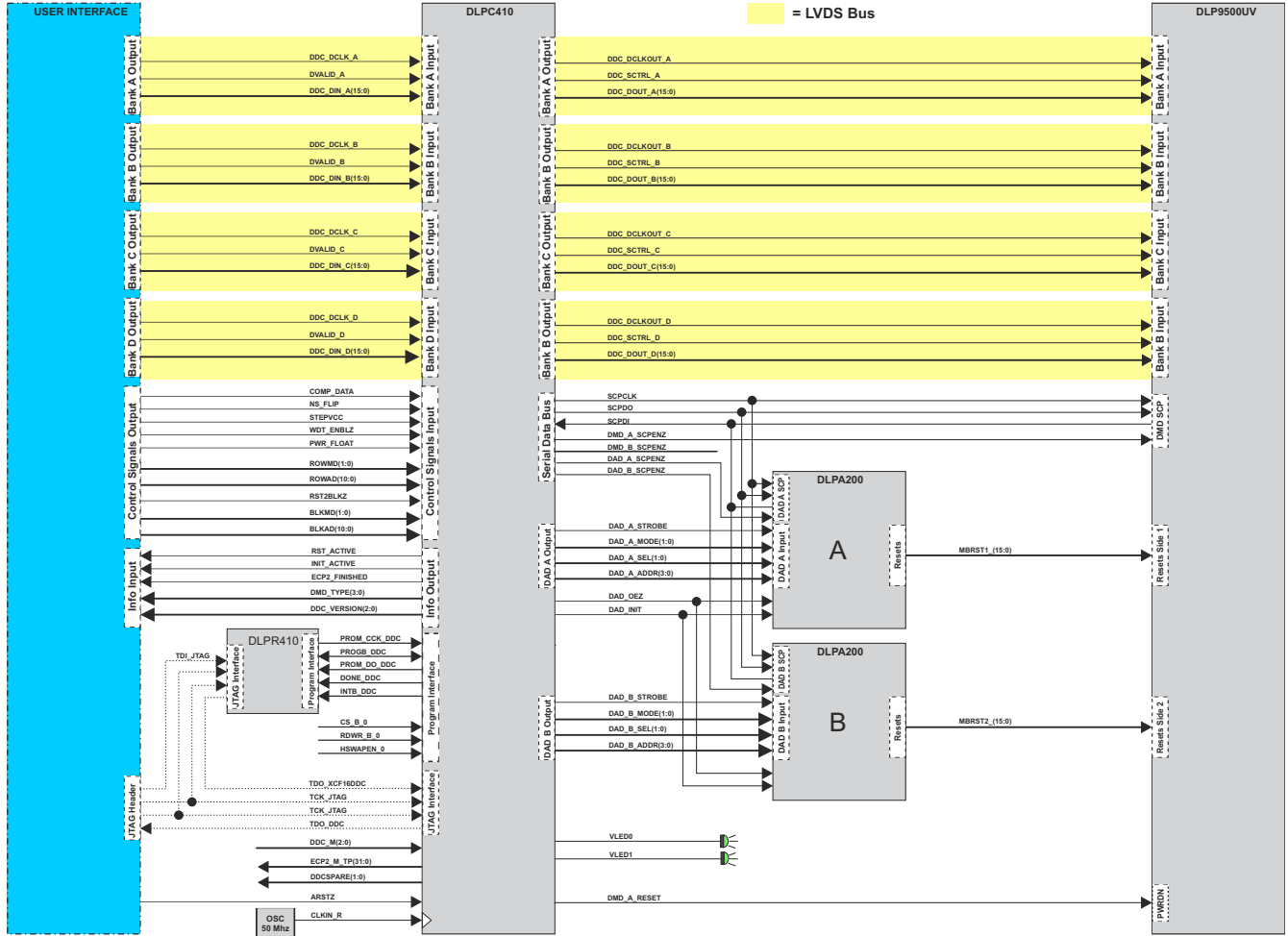

Figure 7-1. DLPC410, DLPA200, DLPR410, and DLP9500UV Functional Block Diagram

## 7.3 Feature Description

**Table 7-1. DMD Overview**

DMD	ARRAY	SINGLE BLOCK MODE (Patterns/s)	GLOBAL RESET MODE (Patterns/s)	DATA RATE (Giga Pixels/s)	MIRROR PITCH
DLP9500UV - 0.95" 1080p	1920 × 1080	23148 <sup>(1)</sup>	17857	48	10.8 μm

(1) This is for single block mode resets.

### 7.3.1 DLPC410—Digital Controller for DLP Discovery 4100 Chipset

The DLPC410 chipset includes the DLPC410 controller, which provides a high-speed LVDS data and control interface for DMD control. This interface is also connected to a second FPGA used to drive applications (not included in the chipset). The DLPC410 generates DMD and DLPA200 initialization and control signals in response to the inputs on the control interface.

For more information, see the DLPC410 data sheet ([DLPS024](#)).

### 7.3.2 DLPA200 - DMD Micromirror Drivers

DLPA200 micromirror drivers provide the micromirror clocking pulse driver functions for the DMD. Two drivers are required for DLP9500UV.

The DLPA200 is designed to work with multiple DLP chipsets. Although the DLPA200 contains 16 MBSRT output pins, only 15 lines are used with the DLP9500 chipset. For more information see [Section Pin Functions](#) and the DLPA200 data sheet ([DLPS015](#)).

### 7.3.3 DLPR410—PROM for DLP Discovery 4100 Chipset

The DLPC410 controller is configured at startup from the DLPR410 PROM. The contents of this PROM can not be altered. For more information, see the DLPR410 data sheet ([DLPS027](#)) the DLPC410 data sheet ([DLPS024](#)).

### 7.3.4 DLP9500—DLP 0.95 1080p 2xLVDS UV Type-A DMD 1080p DMD

#### 7.3.4.1 DLP9500UV 1080p Chipset Interfaces

This section will describe the interface between the different components included in the chipset. For more information on component interfacing, see [Section 8](#).

##### 7.3.4.1.1 DLPC410 Interface Description

###### 7.3.4.1.1.1 DLPC410 IO

[Table 7-2](#) describes the inputs and outputs of the DLPC410 to the user. For more details on these signals, see the DLPC410 data sheet ([DLPS024](#)).

**Table 7-2. Input/Output Description**

PIN NAME	DESCRIPTION	I/O
ARST	Asynchronous active low reset	I
CLKIN_R	Reference clock, 50MHz	I
DIN_[A,B,C,D](15:0)	LVDS DDR input for data bus A,B,C,D (15:0)	I
DCLKIN[A,B,C,D]	LVDS inputs for data clock (200 - 400MHz) on bus A, B, C, and D	I
DVALID[A,B,C,D]	LVDS input used to start write sequence for bus A, B, C, and D	I
ROWMD(1:0)	DMD row address and row counter control	I
ROWAD(10:0)	DMD row address pointer	I
BLK_AD(3:0)	DMD mirror block address pointer	I
BLK_MD(1:0)	DMD mirror block reset and clear command modes	I
PWR_FLOAT	Used to float DMD mirrors before complete loss of power	I
DMD_TYPE(3:0)	DMD type in use	O
RST_ACTIVE	Indicates DMD mirror reset in progress	O
INIT_ACTIVE	Initialization in progress.	O
VLED0	System "heartbeat" signal	O
VLED1	Denotes initialization complete	O

#### 7.3.4.1.1.2 Initialization

The *INIT\_ACTIVE* (Table 7-2) signal indicates that the DLP9500UV, DLPA200s, and DLPC410 are in an initialization state after power is applied. During this initialization period, the DLPC410 is initializing the DLP9500UV and DLPA200s by setting all internal registers to their correct states. When this signal goes low, the system has completed initialization. System initialization takes approximately 220ms to complete. Data and command write cycles should not be asserted during the initialization.

During initialization, the user must send a training pattern to the DLPC410 on all data and DVALID lines to correctly align the data inputs to the data clock. For more information, see the interface training pattern information in the DLPC410 data sheet.

#### 7.3.4.1.1.3 DMD Device Detection

The DLPC410 automatically detects the DMD type and device ID. *DMD\_TYPE* (Table 7-2) is an output from the DLPC410 that contains the DMD information.

#### 7.3.4.1.1.4 Power Down

To ensure long-term reliability of the DLP9500UV, a shutdown procedure must be executed. Prior to power removal, assert the *PWR\_FLOAT* (Table 7-2) signal and allow approximately 300µs for the procedure to complete. This procedure ensures the mirrors are in a flat state.

### 7.3.4.1.2 DLPC410 to DMD Interface

#### 7.3.4.1.2.1 DLPC410 to DMD IO Description

Table 7-3 lists the available controls and status pin names and their corresponding signal type, along with a brief functional description.

**Table 7-3. DLPC410 to DMD I/O Pin Descriptions**

PIN NAME	DESCRIPTION	I/O
DDC_DOUT_[A,B,C,D](15:0)	LVDS DDR output to DMD data bus A,B,C,D (15:0)	O
DDC_DCLKOUT_[A,B,C,D]	LVDS output to DMD data clock A,B,C,D	O
DDC_SCTRL_[A,B,C,D]	LVDS DDR output to DMD data control A,B,C,D	O

### 7.3.4.1.2.2 Data Flow

Figure 7-2 shows the data traffic through the DLPC410. Special considerations are necessary when laying out the DLPC410 to allow best signal flow.

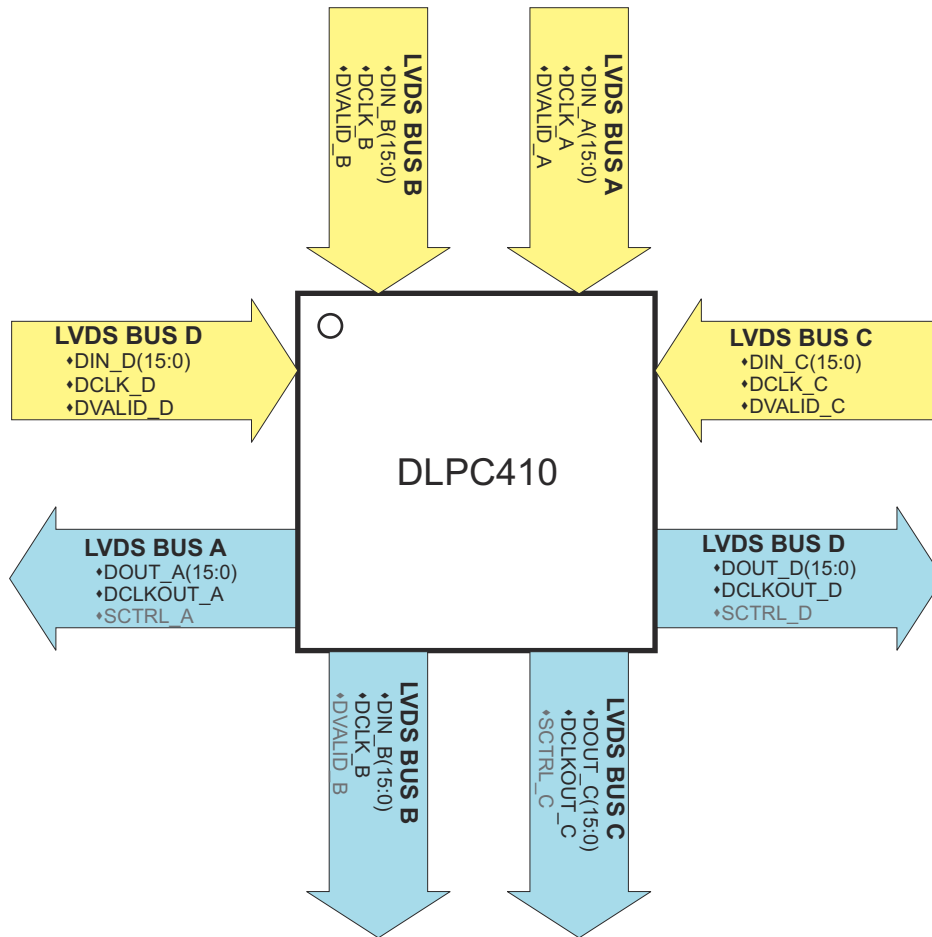

**Figure 7-2. DLPC410 Data Flow**

Four LVDS buses transfer the data from the user to the DLPC410. Each bus has its data clock that is input edge aligned with the data (DCLK). Each bus also has its own validation signal that qualifies the data input to the DLPC410 (DVALID).

Output LVDS buses transfer data from the DLPC410 to the DMD. Output buses LVDS C and LVDS D are used in addition to LVDS A and LVDS B with the DLP9500UV.

### 7.3.4.1.3 DLPC410 to DLPA200 Interface

#### 7.3.4.1.3.1 DLPA200 Operation

The DLPA200 DMD micromirror driver is a mixed-signal application-specific integrated circuit (ASIC) that combines the necessary high-voltage power supply generation and micromirror clocking pulse functions for a family of DMDs. The DLPA200 is programmable and controllable to meet all current and anticipated DMD requirements.

The DLPA200 operates from a 12V power supply input. For more detailed information on the DLPA200, see the DLPA200 data sheet.

### 7.3.4.1.3.2 DLPC410 to DLPA200 IO Description

The serial communications port (SCP) is a full duplex, synchronous, character-oriented (byte) port that allows the exchange of commands from the DLPC410 to the DLPA200s.

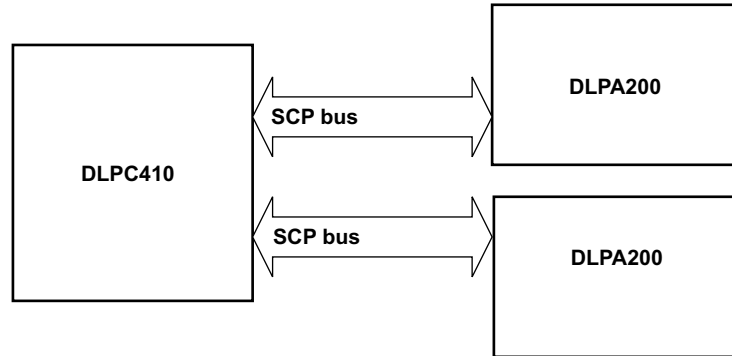

**Figure 7-3. Serial Port System Configuration**

Five signal lines are associated with the SCP bus:  $\overline{\text{SCPEN}}$ , SCPCK, SCPDI, SCPDO, and  $\overline{\text{IRQ}}$ .

Table 7-4 lists the available controls and status pin names and their corresponding signal type, along with a brief functional description.

**Table 7-4. DLPC410 to DLPA200 I/O Pin Descriptions**

PIN NAME	DESCRIPTION	I/O
A_SCPEN	Active-low chip select for DLPA200 serial bus	O
A_STROBE	DLPA200 control signal strobe	O
A_MODE(1:0)	DLPA200 mode control	O
A_SEL(1:0)	DLPA200 select control	O
A_ADDR(3:0)	DLPA200 address control	O
B_SCPEN	Active-low chip select for DLPA200 serial bus (2)	O
B_STROBE	DLPA200 control signal strobe (2)	O
B_MODE(1:0)	DLPA200 mode control	O
B_SEL(1:0)	DLPA200 select control	O
B_ADDR(3:0)	DLPA200 address control	O

The DLPA200 provides a variety of output options to the DMD by selecting logic control inputs: MODE[1:0], SEL[1:0], and reset group address A[3:0] (Table 7-4). The MODE[1:0] input determines whether a single output, two outputs, four outputs, or all outputs are selected. Output levels (VBIAS, VOFFSET, or VRESET) are selected by SEL[1:0] pins. Selected outputs are tri-stated on the rising edge of the STROBE signal and latched to the selected voltage level after a break-before-make delay. Outputs will remain latched at the last micromirror clocking pulse waveform level until the next micromirror clocking pulse waveform cycle.

### 7.3.4.1.4 DLPA200 to DLP9500UV Interface

#### 7.3.4.1.4.1 DLPA200 to DLP9500UV Interface Overview

The DLPA200 generates three voltages: VBIAS, VRESET, and VOFFSET, which are supplied to the DMD MBRST lines in various sequences through the micromirror clocking pulse driver function. VOFFSET is also supplied directly to the DMD as DMDVCC2. A fourth DMD power supply, DMDVCC, is supplied directly to the DMD by regulators.

The function of the micromirror clocking pulse driver is to switch selected outputs in patterns between the three voltage levels (VBIAS, VRESET, and VOFFSET) to generate one of several micromirror clocking pulse waveforms. The order of these micromirror clocking pulse waveform events is controlled externally by the logic

control inputs and timed by the STROBE signal. DLPC410 automatically detects the DMD type and then uses the DMD type to determine the appropriate micromirror clocking pulse waveform.

A direct micromirror clocking pulse operation causes a mirror to transition directly from one latched state to the next. The address must already be set up on the mirror electrodes when the micromirror clocking pulse is initiated. Where the desired mirror display period does not allow for time to set up the address, a micromirror clocking pulse with release can be performed. This operation allows the mirror to go to a relaxed state regardless of the address while a new address is set up, after which the mirror can be driven to a new latched state.

A mirror in the relaxed state typically reflects light into a system collection aperture and can be thought of as *off*, although the light is likely to be more than a mirror latched in the *off* state. System designers should carefully evaluate the impact of relaxed mirror conditions on optical performance.

### 7.3.5 Measurement Conditions

The data sheet provides timing at the device pin. For output timing analysis, the tester pin electronics and its transmission line effects must be taken into account. Figure 7-4 shows an equivalent test load circuit for the output under test. The load capacitance value stated is only for characterization and measurement of AC timing signals. This load capacitance value does not indicate the maximum load the device is capable of driving. All rise and fall transition timing parameters are referenced to  $V_{IL}$  MAX and  $V_{IH}$  MIN for input clocks,  $V_{OL}$  MAX and  $V_{OH}$  MIN for output clocks.

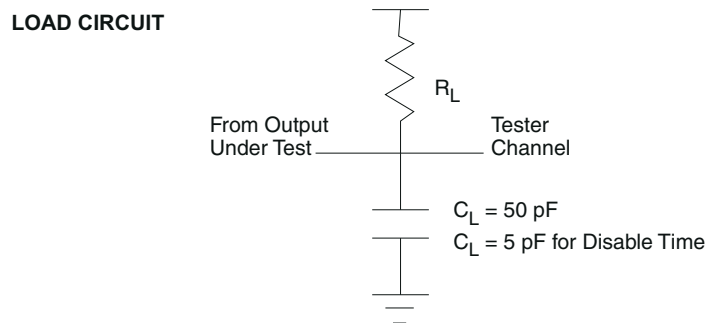

**Figure 7-4. Test Load Circuit for AC Timing Measurements**

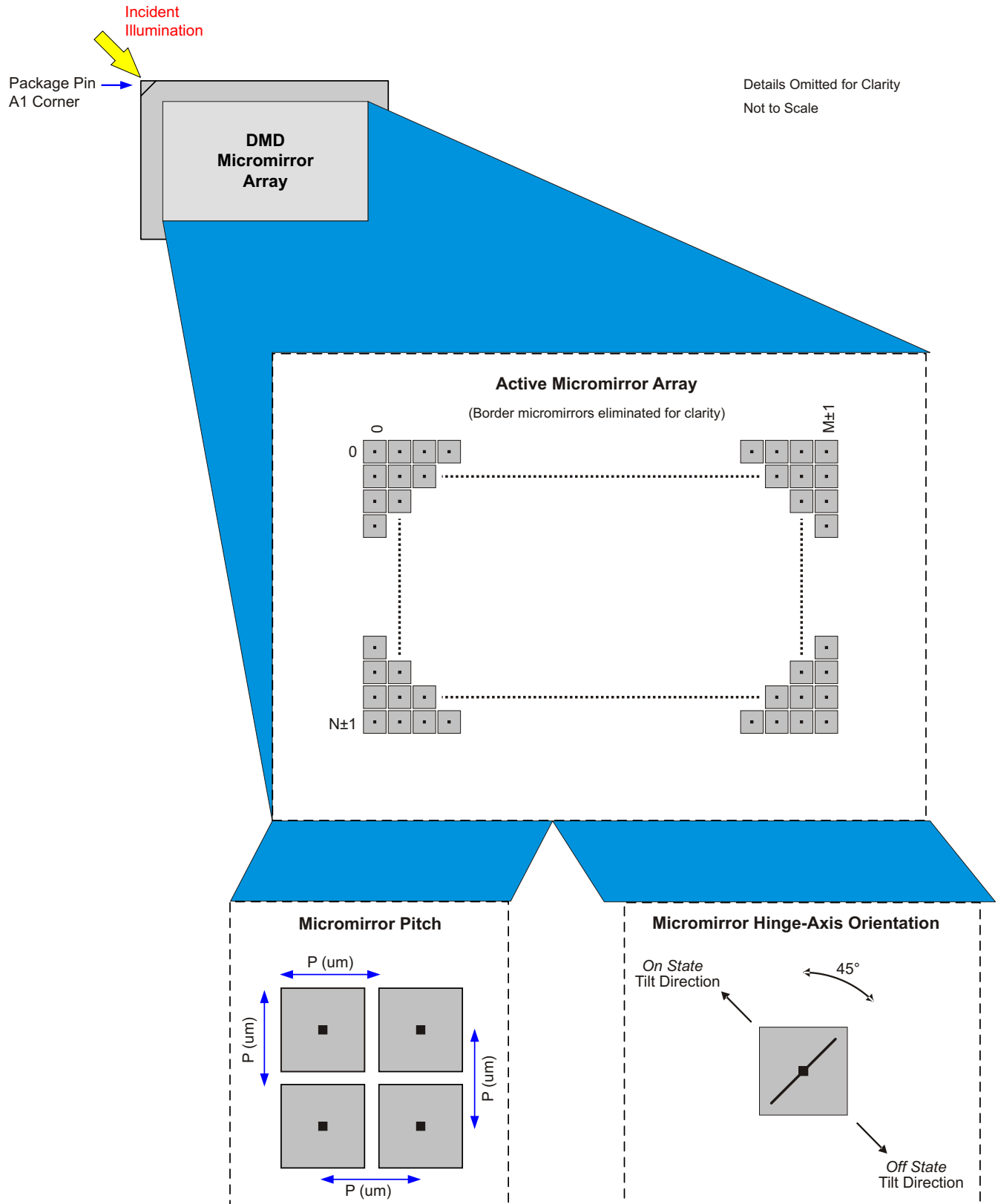

Figure 7-5. DMD Micromirror Array, Pitch, and Hinge-Axis Orientation

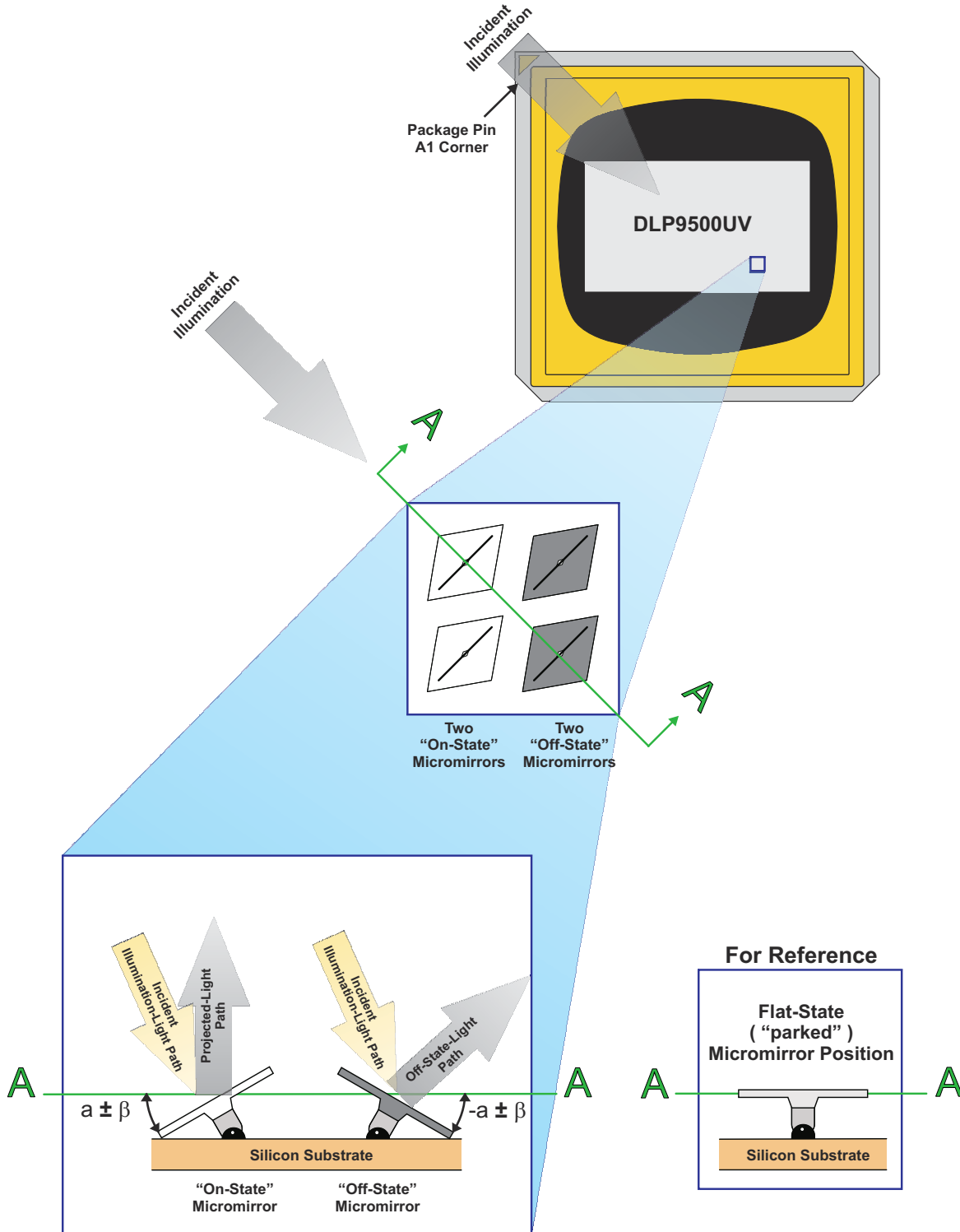

Figure 7-6. Micromirror Landed Positions and Light Paths



## 7.4 Device Functional Modes

The DLP9500UV has only one functional mode; it is set to be highly optimized for low latency and high speed in generating mirror clocking pulses and timings.

When operated with the DLPC410 controller in conjunction with the DLPA200 drivers, the DLP9500UV can be operated in several display modes. The DLP9500UV is loaded as 15 blocks of 72 rows each. The first 64 bits of pixel data and the last 64 bits of pixel data for all rows are not visible. Below is a representation of how the image is loaded by the different micromirror clocking pulse modes. [Figure 7-7](#), [Figure 7-8](#), [Figure 7-9](#), and [Figure 7-10](#) show how the image is loaded by the different micromirror clocking pulse modes.

There are four micromirror clocking pulse modes that determine which blocks are *reset* when a micromirror clocking pulse command is issued:

- Single block mode
- Dual block mode
- Quad block mode
- Global mode

### 7.4.1 Single Block Mode

In single block mode, a single block can be loaded and reset in any order. After a block is loaded, it can be reset to transfer the information to the mechanical state of the mirrors.

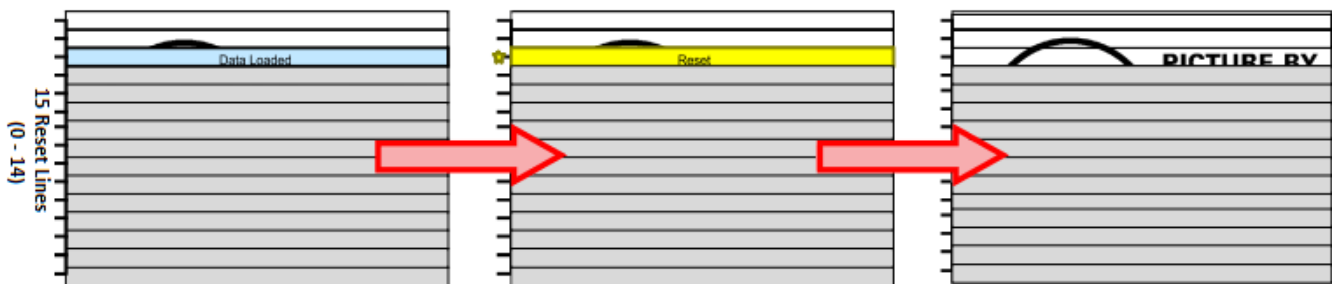

**Figure 7-7. Single Block Mode**

### 7.4.2 Dual Block Mode

In dual block mode, reset blocks are paired together as follows (0-1), (2-3), (4-5), (6-7), (8-9), (10-11), (12-13), and (14). These pairs can be reset in any order. After data is loaded, a pair can be reset to transfer the information to the mechanical state of the mirrors.

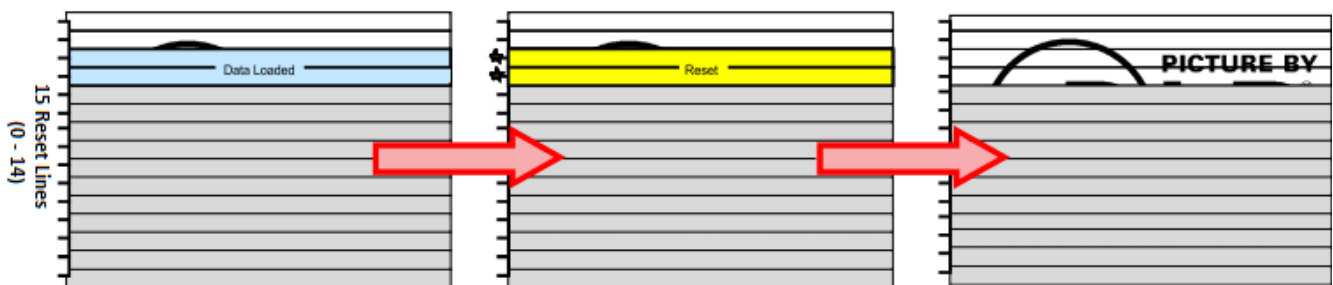

**Figure 7-8. Dual Block Mode**

### 7.4.3 Quad Block Mode

In quad block mode, reset blocks are grouped together in fours as follows (0-3), (4-7), (8-11), and (12-14). Each quad group can be randomly addressed and reset. After a quad group is loaded, it can be reset to transfer the information to the mechanical state of the mirrors.

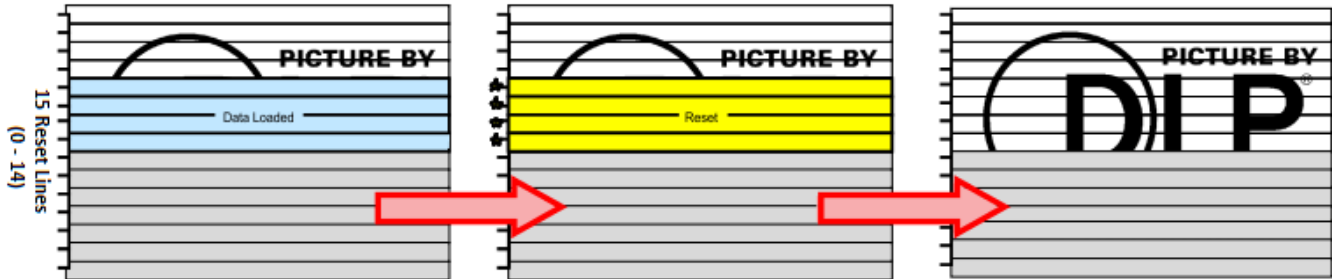

Figure 7-9. Quad Block Mode

### 7.4.4 Global Block Mode

In global mode, all reset blocks are grouped into a single group and reset together. The entire DMD must be loaded with the desired data before issuing a Global Reset to transfer the information to the mechanical state of the mirrors.

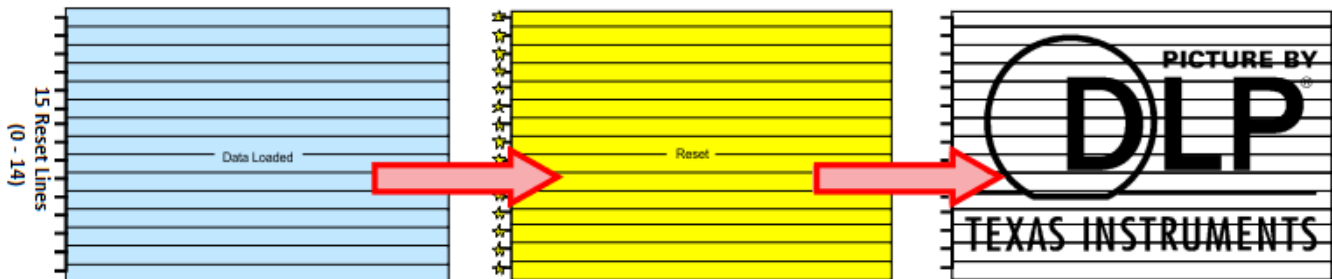

Figure 7-10. Global Mode

## 7.5 Window Characteristics and Optics

---

### Note

TI assumes no responsibility for image quality artifacts or DMD failures caused by optical system operating conditions exceeding limits described previously.

---

#### 7.5.1 Optical Interface and System Image Quality

TI assumes no responsibility for end-equipment optical performance. Achieving the desired end-equipment optical performance involves making trade-offs between numerous component and system design parameters. Optimizing system optical performance and image quality strongly relate to optical system design parameter trades. Although it is not possible to anticipate every conceivable application, projector image quality and optical performance is contingent on compliance to the optical system operating conditions described in the following sections.

#### 7.5.2 Numerical Aperture and Stray Light Control

The angle defined by the numerical aperture of the illumination and projection optics at the DMD optical area should be the same. This angle should not exceed the nominal device mirror tilt angle unless appropriate apertures are added in the illumination, projection pupils, or both to block out flat-state and stray light from the projection lens. The mirror tilt angle defines DMD capability to separate the *ON* optical path from any other light path, including undesirable flat-state specular reflections from the DMD window, DMD border structures, or other system surfaces near the DMD, such as prism or lens surfaces. If the numerical aperture exceeds the mirror tilt angle, or if the projection numerical aperture angle is more than two degrees larger than the illumination numerical aperture angle, objectionable artifacts in the display's border and/or active area could occur.

#### 7.5.3 Pupil Match

TI recommends the exit pupil of the illumination is nominally centered within 2° (two degrees) of the entrance pupil of the projection optics. Misalignment of pupils can create objectionable artifacts in the display's border and/or active area, which may require additional system apertures to control, especially if the numerical aperture of the system exceeds the pixel tilt angle.

#### 7.5.4 Illumination Overfill

The active area of the device is surrounded by an aperture on the inside DMD window surface that masks structures of the DMD device assembly from normal view. The aperture is sized to anticipate several optical operating conditions. Overfill light illuminating the window aperture can create artifacts from the edge of the window aperture opening and other surface anomalies that may be visible on the screen. The illumination optical system should be designed to limit light flux incident anywhere on the window aperture from exceeding approximately 10% of the average flux level in the active area. Depending on the optical architecture of a particular system, overfill light may have to be further reduced below the suggested 10% level to be acceptable.

## 7.6 Micromirror Array Temperature Calculation

Achieving optimal DMD performance requires proper management of the maximum DMD case temperature, the maximum temperature of any individual micromirror in the active array, the maximum temperature of the window aperture, and the temperature gradient between case temperature and the predicted micromirror array temperature (See [Figure 7-11](#)).

See the [Recommended Operating Conditions](#) for applicable temperature limits.

### 7.6.1 Package Thermal Resistance

The DMD is designed to conduct absorbed and dissipated heat to the back of the Type A package where it can be removed by an appropriate heat sink. The heat sink and cooling system must be capable of maintaining the package within the specified operational temperatures, refer to [Figure 7-11](#). The total heat load on the DMD is typically driven by the incident light absorbed by the active area; although other contributions include light energy absorbed by the window aperture and electrical power dissipation of the array.

### 7.6.2 Case Temperature

The temperature of the DMD case can be measured directly. For consistency, Thermal Test Point locations 1, 2, and 3 are defined, as shown in Thermal Test Point Location below.

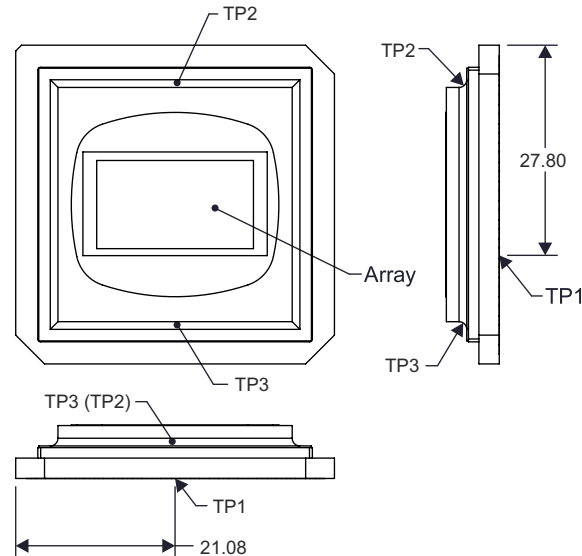

**Figure 7-11. Thermal Test Point Location**

### 7.6.3 Micromirror Array Temperature Calculation

Active array temperature cannot be measured directly; therefore, it must be computed analytically from measurement points on the outside of the package, package thermal resistance, electrical power, and illumination heat load. The relationship between array temperature and the reference ceramic temperature (test point number 1 in [Figure 7-11](#)) is provided by the following equations:

$T_{\text{Array}} = \text{Measured Ceramic temperature at location (test point number 3) + (Temperature increase due to power incident to the array} \times \text{array-to-ceramic resistance)}$

$$= T_{\text{Ceramic}} + (Q_{\text{Array}} \times R_{\text{Array-To-Ceramic}})$$

where

- $T_{\text{Ceramic}}$  = Measured ceramic temperature (°C) at location (test point number 3)
- $R_{\text{Array-To-Ceramic}}$  = DMD package thermal resistance from array to outside ceramic (°C/W)
- $Q_{\text{Array}}$  = Total DMD array power, which is both electrical plus absorbed on the DMD active array (W)
- $Q_{\text{Array}} = Q_{\text{Electrical}} + (Q_{\text{Illumination}} \times \text{DMD absorption constant (0.42)})$

where

- $Q_{\text{Electrical}}$  = Approximate nominal electrical internal power dissipation (W)
- $Q_{\text{Illumination}} = [\text{Illumination power density} \times \text{illumination area on DMD}]$  (W)
- DMD absorption constant = 0.42

The electrical power dissipation of the DMD is variable and depends on the voltages, data rates, and operating frequencies. The nominal electrical power dissipation of the DMD is variable and depends on the operating state of the mirrors and the intensity of the light source. The DMD absorption constant of 0.42 assumes nominal operation with an illumination distribution of 83.7% on the active array, 11.9% on the array border, and 4.4% on the window aperture. A system aperture may be required to limit the power incident on the package aperture since this area absorbs much more efficiently than the array.

#### Sample Calculation:

(1)

- Illumination power density = 2W/cm<sup>2</sup>
- Illumination area = (1.4008cm × 1.0506cm) / 83.7% = 1.76cm<sup>2</sup> (assumes 83.7% on the active array and 16.3% overfill)
- $Q_{\text{Illumination}} = 2\text{W/cm}^2 \times 1.76\text{cm}^2 = 3.52\text{W}$
- $Q_{\text{Electrical}} = 2.0\text{W}$
- $R_{\text{Array-To-Ceramic}} = 0.9^\circ\text{C/W}$
- $T_{\text{Ceramic}} = 20^\circ\text{C}$  (measured on ceramic)
- $Q_{\text{Array}} = 2.0\text{W} + (3.52\text{W} \times 0.42) = 3.48\text{W}$
- $T_{\text{Array}} = 20^\circ\text{C} + (3.48\text{W} \times 0.9^\circ\text{C/W}) = 23.1^\circ\text{C}$

## 7.7 Micromirror Landed-On and Landed-Off Duty Cycle

### 7.7.1 Definition of Micromirror Landed-On/Landed-Off Duty Cycle

The micromirror landed-on/landed-off duty cycle (landed duty cycle) denotes the amount of time (as a percentage) that an individual micromirror is landed in the on-state versus the amount of time the same micromirror is landed in the off-state.

As an example, a landed duty cycle of 100/0 indicates that the referenced pixel is in the On-state 100% of the time (and in the Off-state 0% of the time); whereas 0/100 would indicate that the pixel is in the Off-state 100% of the time. Likewise, 50/50 indicates that the pixel is on 50% of the time and Off 50% of the time.

Note that when assessing landed duty cycle, the time spent switching from one state (ON or OFF) to the other state (OFF or ON) is considered negligible and is thus ignored.

Because a micromirror can only be landed in one state or the other (on or off), the two numbers (percentages) always add to 100.

### 7.7.2 Landed Duty Cycle and Useful Life of the DMD

Knowing the long-term average landed duty cycle (of the end product or application) is important because subjecting all (or a portion) of the DMD's micromirror array (also called the active array) to an asymmetric landed duty cycle for a prolonged period of time can reduce the usable life of the DMD.

Note that it is the symmetry/asymmetry of the landed duty cycle that is of relevance. The symmetry of the landed duty cycle is determined by how close the two numbers (percentages) are to being equal. For example, a landed duty cycle of 50/50 is perfectly symmetrical whereas a landed duty cycle of 100/0 or 0/100 is perfectly asymmetrical.

### 7.7.3 Landed Duty Cycle and Operational DMD Temperature

Operational DMD temperature and landed duty cycle interact to affect the usable life of the DMD, and this interaction can be exploited to reduce the impact that an asymmetrical landed duty cycle has on the DMD's usable life.

In practice, this curve specifies the maximum operating DMD temperature that the DMD should be operated at for a given long-term average landed duty.

### 7.7.4 Estimating the Long-Term Average Landed Duty Cycle of a Product or Application

During a given period of time, the landed duty cycle of a given pixel follows from the image content being displayed by that pixel.

For example, in the simplest case, when displaying pure white on a given pixel for a given time period, that pixel will experience a 100/0 landed duty cycle during that time period. Likewise, when displaying pure black, the pixel will experience a 0/100 landed duty cycle.

Between the two extremes (ignoring, for the moment, color and any image processing that may be applied to an incoming image), the landed duty cycle tracks one-to-one with the grayscale value, as shown in [Table 7-5](#).

**Table 7-5. Grayscale Value and Landed Duty Cycle**

GRAYSCALE VALUE	LANDED DUTY CYCLE
0%	0/100
10%	10/90
20%	20/80
30%	30/70
40%	40/60
50%	50/50
60%	60/40
70%	70/30
80%	80/20
90%	90/10
100%	100/0

## 8 Application and Implementation

### Note

Information in the following applications sections is not part of the TI component specification, and TI does not warrant its accuracy or completeness. TI's customers are responsible for determining suitability of components for their purposes, as well as validating and testing their design implementation to confirm system functionality.

### 8.1 Application Information

The DLP9500UV devices must be coupled with the DLPC410 controller to provide a reliable solution for many different applications. The DMDs are spatial light modulators that reflect incoming light from an illumination source to one of two directions, with the primary direction being into a projection collection optic. Each application is derived primarily from the optical architecture of the system and the format of the data coming into the DLPC410. Applications of interest include 3D printing, lithography, medical systems, and compressive sensing.

#### 8.1.1 DMD Reflectivity Characteristics

TI assumes no responsibility for end-equipment reflectivity performance. Achieving the desired end-equipment reflectivity performance involves making trade-offs between numerous component and system design parameters. Typical DMD reflectivity characteristics over UV exposure times are represented in [Figure 8-1](#).

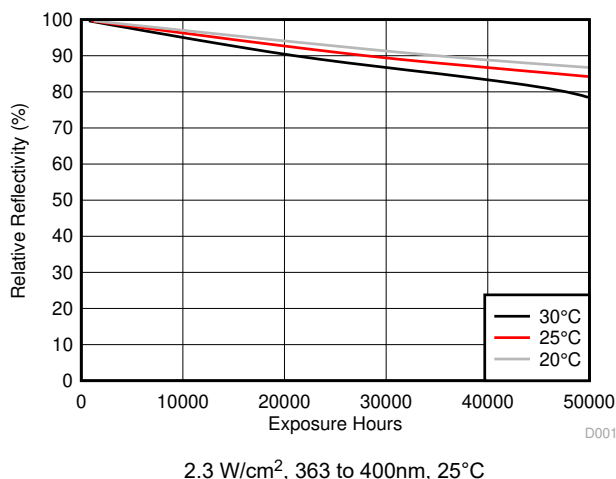

**Figure 8-1. Nominal DMD Relative Reflectivity Percentage vs Total Exposure Hours**

DMD reflectivity includes micromirror surface reflectivity and window transmission. The DMD was characterized for DMD reflectivity using a broadband light source (200W metal-halide lamp). Data is based on a 2.3W/cm<sup>2</sup> UV exposure at the DMD surface (365nm peak output) using a 363nm high-pass filter between the light source and the DMD. (Contact your local Texas Instruments representative for additional information about power density measurements and UV filter details.)

#### 8.1.1.1 Design Considerations Influencing DMD Reflectivity

Optimal, long-term performance of the digital micromirror device (DMD) can be affected by various application parameters. The following is a list of some of these application parameters and includes high level design recommendations that may help extend relative reflectivity from time zero:

- Illumination spectrum—using longer wavelengths for operation while preventing shorter wavelengths from striking the DMD
- Illumination power density—using lower power density



- DMD case temperature—operating the DMD with the case temperature at the low end of its specification
- Cumulative incident illumination—Limiting the total hours of UV illumination exposure when the DMD is not actively steering UV light in the application. For example, a design might include a shutter to block the illumination or LED illumination where the LEDs can be strobed off during periods not requiring UV exposure.
- Micromirror landed duty cycle—applying a 50/50 duty cycle pattern during periods where operational patterns are not required.

## 8.2 Typical Application

The DLP9500UV DMD is designed with a window that allows transmission of ultraviolet (UV) light. This makes it well suited for UV applications requiring fast, spatially programmable light patterns using the micromirror array. UV wavelengths can affect the DMD differently from visible wavelengths. There are system-level considerations that should be leveraged when designing systems using this DMD.

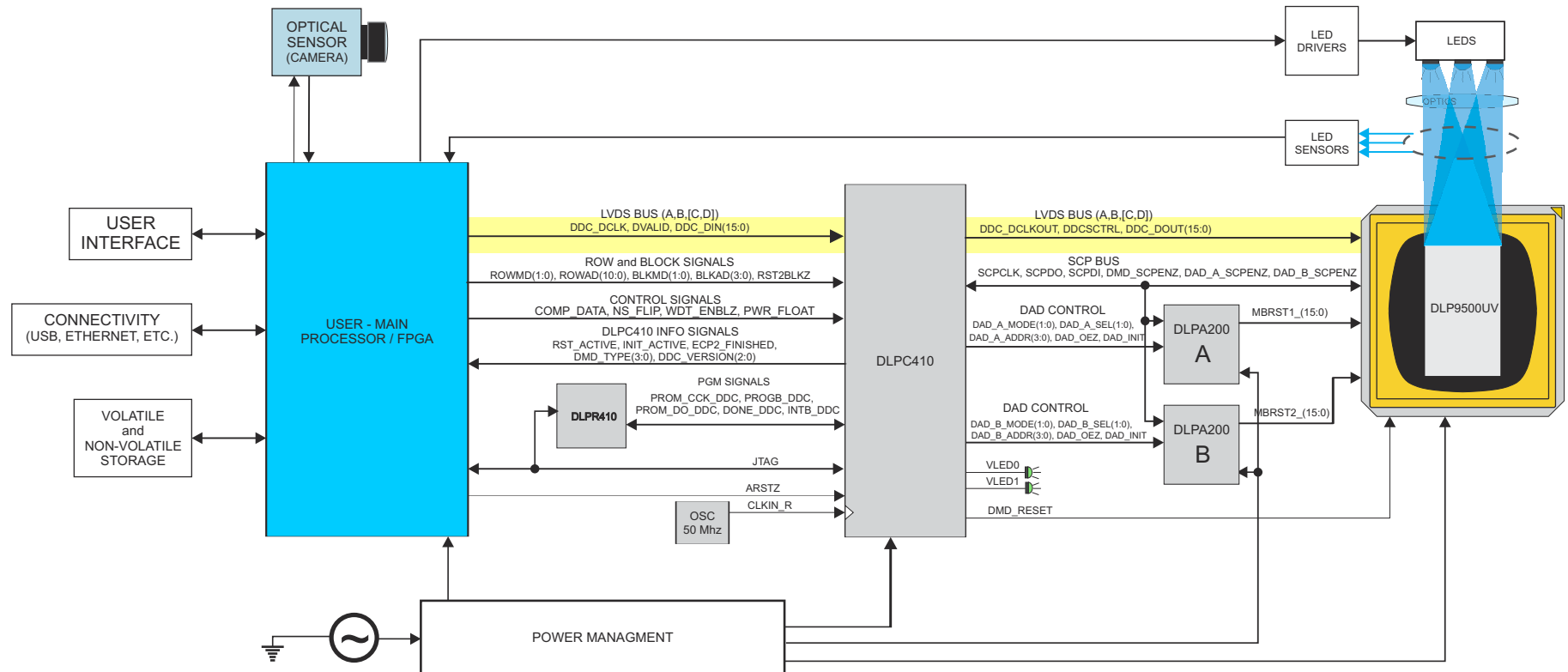

Figure 8-2. DLPC410 and DLP9500UV Embedded Example Block Diagram

### 8.2.1 Design Requirements

All applications using the DLP9500UV chipset require both the controller and the DMD components for operation. The system also requires an external parallel flash memory device loaded with the DLPC410 configuration and support firmware. The chipset has several system interfaces and requires some support circuitry. The following interfaces and support circuitry are required:

- DLPC410 system interfaces:
  - Control interface
  - Trigger interface
  - Input data interface
  - Illumination interface
  - Reference clock
  - Program interface
- DLP9500UV interfaces:
  - DLPC410 to DLP9500UV digital data
  - DLPC410 to DLP9500UV control interface
  - DLPC410 to DLP9500UV micromirror reset control interface
  - DLPC410 to DLPA200 micromirror driver
  - DLPA200 to DLP9500UV micromirror reset

#### 8.2.1.1 Device Description

The DLP9500UV 1080p chipset offers developers a convenient way to design a wide variety of industrial, medical, telecom, and advanced display applications by delivering maximum flexibility in formatting data, sequencing data, and light patterns.

The DLP9500UV 1080p chipset includes the following four components: DMD digital controller (DLPC410), EEPROM (DLPR410), DMD micromirror driver (DLPA200), and a DMD (DLP9500UV).

#### **DLPC410** Digital Controller for DLP Discovery 4100 chipset

- Provides high-speed 2xLVDS data and control interface to the user
- Drives mirror clocking pulse and timing information to the DLPA200
- Supports random row addressing
- Controls illumination

#### **DLPR410** PROM for DLP Discovery 4100 chipset

- Contains startup configuration information for the DLPC410

#### **DLPA200** DMD Micromirror Driver

- Generates micromirror clocking pulse control (sometimes referred to as a reset) of 15 banks of DMD mirrors. (Two are required for the DLP9500UV).

#### **DLP9500UV** DLP 0.95 1080p 2xLVDS UV Type-A DMD

- Steers light in two digital positions (+12° and –12°) using 1920 × 1080 micromirror array of aluminum mirrors.

**Table 8-1. DLP DLP9500UV Chipset Configurations**

QUANTITY	TI PART	DESCRIPTION
1	DLP9500UV	DLP 0.95 1080p 2xLVDS UV Type-A DMD
1	DLPC410	Digital Controller for DLP Discovery 4100 chipset
1	DLPR410	PROM for DLP Discovery 4100 chipset
2	DLPA200	DMD Micromirror Driver

Reliable function and operation of DLP9500UV 1080p chipsets require the components to be used in conjunction with each other. This document describes the proper integration and use of the DLP9500UV 1080p chipset components.

The DLP9500UV 1080p chipset can be combined with a user-programmable application FPGA (not included) to create high-performance systems.

### 8.2.2 Detailed Design Procedure

The DLP9500UV DMD is designed with a window which allows transmission of UV light. This makes it well suited for UV applications requiring fast, spatially programmable light patterns using the micromirror array. UV wavelengths can affect the DMD differently than visible wavelengths. There are system level considerations which should be leveraged when designing systems using this DMD.

### 8.2.3 Application Curve

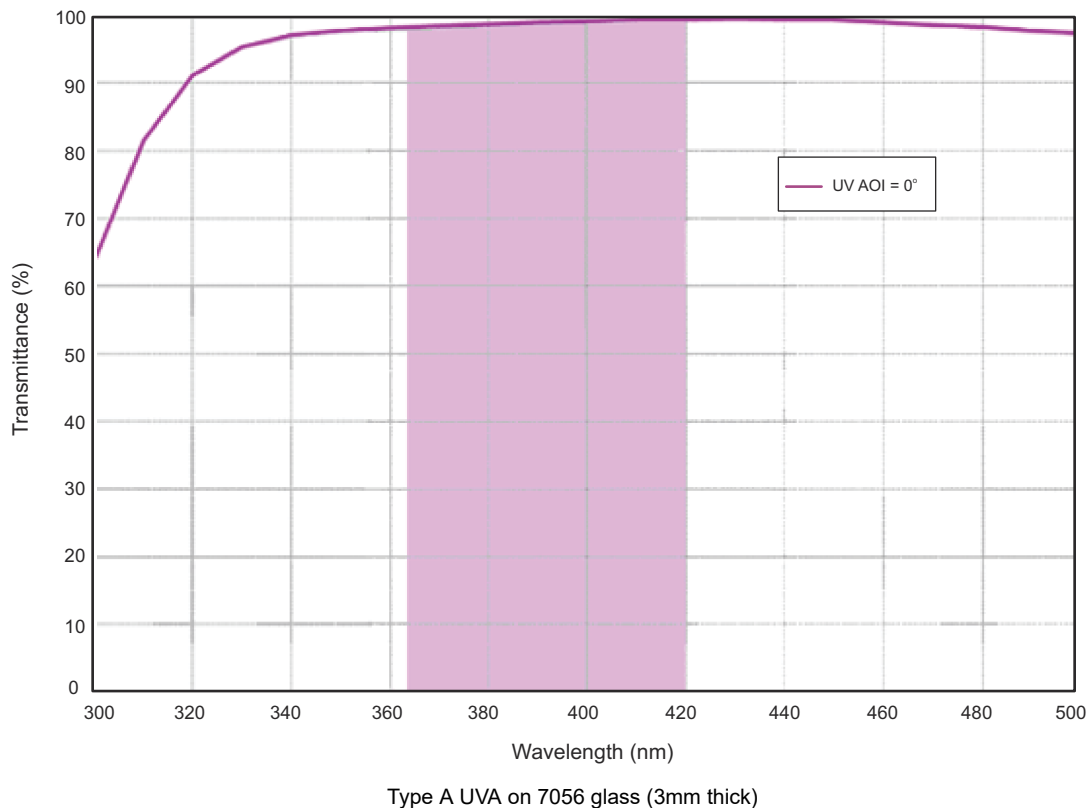

**Figure 8-3. Corning 7056 UV Window Transmittance (Maximum Transmission Region)**

## 8.3 Power Supply Recommendations

### 8.3.1 Power-Up Sequence (Handled by the DLPC410)

The sequence of events for the DMD system power-up is as follows:

1. Apply logic supply voltages to the DLPA200 and to the DMD according to DMD specifications.
2. Place DLPA200 drivers into high-impedance states.
3. Turn on DLPA200 bias, offset, or reset supplies according to driver specifications.
4. After all supply voltages are assured to be within the limits specified and with all micromirror clocking pulse operations logically suspended, enable all drivers to either VOFFSET or VBIAS level.
5. Begin micromirror clocking pulse operations.

### 8.3.2 DMD Power-Up and Power-Down Procedures

Failure to adhere to the prescribed power-up and power-down procedures may affect device reliability. The DLP9500UV power-up and power-down procedures are defined by the DLPC410 data sheet ([DLPS024](#)). These procedures must be followed to ensure reliable operation of the device.

## 8.4 Layout

### 8.4.1 Layout Guidelines

The DLP9500UV is part of a chipset that is controlled by the DLPC410 in conjunction with the DLPA200. These guidelines are targeted at designing a PCB board with these components.

#### 8.4.1.1 Impedance Requirements

Signals should be routed to have a matched impedance of  $50\Omega \pm 10\%$  except for LVDS differential pairs (DMD\_DAT\_Xnn, DMD\_DCKL\_Xn, and DMD\_SCTRL\_Xn), which should be matched to  $100\Omega \pm 10\%$  across each pair.

#### 8.4.1.2 PCB Signal Routing

When designing a PCB board for the DLP9500UV controlled by the DLPC410 in conjunction with the DLPA200s, the following are recommended:

Signal trace corners should be no sharper than  $45^\circ$ . Adjacent signal layers should have the predominant traces routed orthogonal to each other. TI recommends that critical signals be hand routed in the following order: DDR2 Memory, DMD (LVDS signals), then DLPA200 signals.

TI does not recommend signal routing on power or ground planes.

TI does not recommend ground plane slots.

High-speed signal traces should not cross over slots in adjacent power and/or ground planes.

**Table 8-2. Important Signal Trace Constraints**

SIGNAL	CONSTRAINTS
LVDS (DMD_DAT_xnn, DMD_DCKL_xn, and DMD_SCTRL_xn)	P-to-N data, clock, and SCTRL: <10mils (0.25mm); Pair-to-pair <10mils (0.25mm); Bundle-to-bundle <2000mils (50mm, for example DMD_DAT_Ann to DMD_DAT_Bnn) Trace width: 4mil (0.1mm) Trace spacing: In ball field – 4mil (0.11mm); PCB etch – 14mil (0.36 mm) Maximum recommended trace length <6 inches (150mm)

**Table 8-3. Power Trace Widths and Spacing**

SIGNAL NAME	MINIMUM TRACE WIDTH	MINIMUM TRACE SPACING	LAYOUT REQUIREMENTS
GND	Maximize	5mil (0.13mm)	Maximize trace width to connecting pin as a minimum
VCC, VCC2	20 mil (0.51mm)	10 mil (0.25mm)	
MBRST[14:0]	11 mil (0.28mm)	15mil (0.38mm)	

#### 8.4.1.3 Fiducials

Fiducials for automatic component insertion should be 0.05-inch copper with a 0.1-inch cutout (antipad). Fiducials for optical auto insertion are placed on three corners of both sides of the PCB.

#### 8.4.1.4 PCB Layout Guidelines

A target impedance of  $50\Omega$  for single-ended signals and  $100\Omega$  between LVDS signals is specified for all signal layers.

##### 8.4.1.4.1 DMD Interface

The digital interface from the DLPC410 to the DMD are LVDS signals that run at clock rates up to 400MHz. Data is clocked into the DMD on both the rising and falling edge of the clock, so the data rate is 800MHz. The LVDS signals should have  $100\Omega$  differential impedance. The differential signals should be matched but kept as

short as possible. Parallel termination at the LVDS receiver is in the DMD; therefore, on-board termination is not necessary.

#### **8.4.1.4.1.1 Trace Length Matching**

The DLPC410 DMD data signals require precise length matching. Differential signals should have an impedance of 100Ω (with 5% tolerance). It is important that the propagation delays are matched. The maximum differential pair uncoupled length is 100 mils with a relative propagation delay of  $\pm 25$ mil between the p and n. Matching all signals exactly will maximize the channel margin. The signal path through all boards, flex cables, and internal DMD routing must be considered in this calculation.

#### **8.4.1.4.2 DLP9500UV Decoupling**

General decoupling capacitors for the DLP9500UV should be distributed around the PCB and placed to minimize the distance from IC voltage and ground pads. Each decoupling capacitor (0.1μF recommended) should have vias directly to the ground and power planes. Via sharing between components (discrete or integrated) is discouraged. The power and ground pads of the DLP9500UV should be tied to the voltage and ground planes with their vias.

##### **8.4.1.4.2.1 Decoupling Capacitors**

Decoupling capacitors should be placed to minimize the distance from the decoupling capacitor to the supply and ground pin of the component. TI recommends that the placement of and routing for the decoupling capacitors meet the following guidelines:

- The supply voltage pin of the capacitor should be located close to the device supply voltage pin or pins. The decoupling capacitor should have vias to ground and voltage planes. The device can be connected directly to the decoupling capacitor (no via) if the trace length is less than 0.1 inch. Otherwise, the component should be tied to the voltage or ground plane through separate vias.
- The trace lengths of the voltage and ground connections for decoupling capacitors and components should be less than 0.1 inch to minimize inductance.
- The trace width of the power and ground connection to decoupling capacitors and components should be as wide as possible to minimize inductance.
- Connecting decoupling capacitors to ground and power planes through multiple vias can reduce inductance and improve noise performance.
- Decoupling performance can be improved by using low ESR and low ESL capacitors.

##### **8.4.1.4.3 VCC and VCC2**

The VCC pins of the DMD should be connected directly to the DMD VCC plane. Decoupling for the VCC should be distributed around the DMD and placed to minimize the distance from the voltage and ground pads. Each decoupling capacitor should have vias directly connected to the ground and power planes. The VCC and GND pads of the DMD should be tied to the VCC and ground planes with their vias.

The VCC2Voltage can be routed to the DMD as a trace. Decoupling capacitors should be placed to minimize the distance from the DMD's VCC2 and ground pads. Using a wide etch from the decoupling capacitors to the DMD connection will reduce inductance and improve decoupling performance.

##### **8.4.1.4.4 DMD Layout**

See the respective sections in this data sheet for package dimensions, timing, and pinout information.

##### **8.4.1.4.5 DLPA200**

The DLPA200 generates the micromirror clocking pulses for the DMD. The DMD-drive outputs from the DLPA200 (MBRST[29:0]) should be routed with a minimum trace width of 11mil and a minimum spacing of 15mil. The VCC and VCC2 traces from the output capacitors to the DLPA200 should also be routed with a minimum trace width and spacing of 11mil and 15mil, respectively. See [DLPA200 Digital Micromirror Device Driver Data Sheet](#) for mechanical package and layout information.

### 8.4.2 Layout Example

For LVDS (and other differential signal) pairs and groups, it is important to match trace lengths. In the area of the dashed lines, [Figure 8-4](#) shows correct matching of signal pair lengths with serpentine sections to maintain the correct impedance.

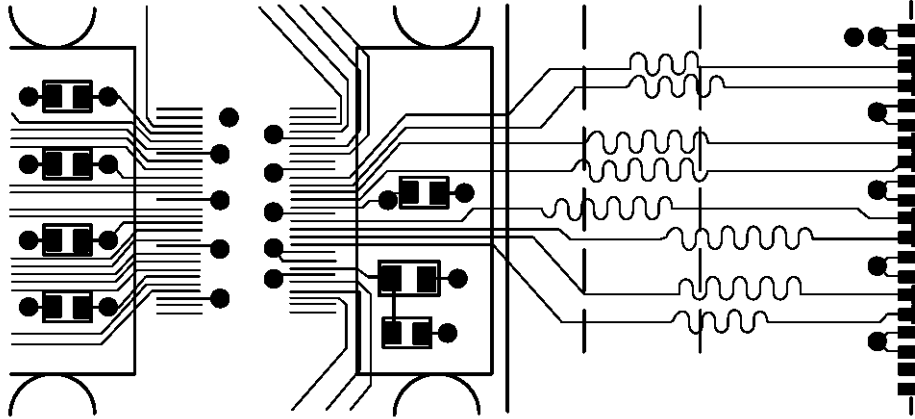

**Figure 8-4. Mitering LVDS Traces to Match Lengths**

## 9 Device and Documentation Support

### 9.1 Device Support

#### 9.1.1 Device Nomenclature

Figure 9-1 provides a legend of reading the complete device name for any DLP device.

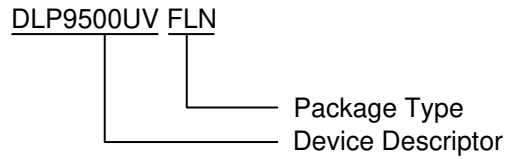

Figure 9-1. Device Nomenclature

#### 9.1.2 Device Marking

Figure 9-2 shows the device marking fields.

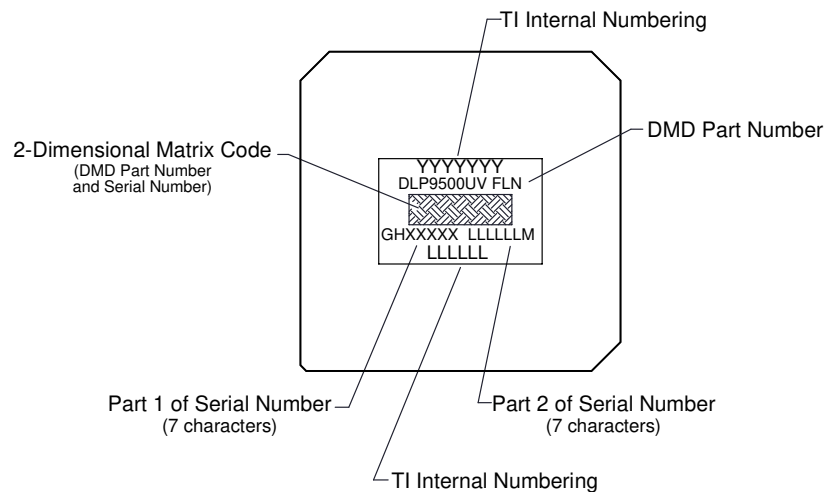

Figure 9-2. DLP9500UV Device Marking



## 9.2 Documentation Support

### 9.2.1 Related Documentation

The following documents contain additional information related to the use of the DLP9500UV device.

- [DLPC410 Digital Controller for DLP Discovery 4100 Chipset Data Sheet](#)
- [DLPA200 Digital Micromirror Device Driver Data Sheet](#)
- [DLPR410 PROM for DLP Discovery 4100 Chipset Data Sheet](#)

## 9.3 Related Links

The table below lists quick access links. Categories include technical documents, support and community resources, tools and software, and quick access to sample or buy.

**Table 9-1. Related Links**

PARTS	PRODUCT FOLDER	SAMPLE & BUY	TECHNICAL DOCUMENTS	TOOLS & SOFTWARE	SUPPORT & COMMUNITY
DLP9500UV	<a href="#">Click here</a>	<a href="#">Click here</a>	<a href="#">Click here</a>	<a href="#">Click here</a>	<a href="#">Click here</a>
DLPA200	<a href="#">Click here</a>	<a href="#">Click here</a>	<a href="#">Click here</a>	<a href="#">Click here</a>	<a href="#">Click here</a>
DLPC410	<a href="#">Click here</a>	<a href="#">Click here</a>	<a href="#">Click here</a>	<a href="#">Click here</a>	<a href="#">Click here</a>
DLPR410	<a href="#">Click here</a>	<a href="#">Click here</a>	<a href="#">Click here</a>	<a href="#">Click here</a>	<a href="#">Click here</a>

## 9.4 Support Resources

[TI E2E™ support forums](#) are an engineer's go-to source for fast, verified answers and design help — straight from the experts. Search existing answers or ask your own question to get the quick design help you need.

Linked content is provided "AS IS" by the respective contributors. They do not constitute TI specifications and do not necessarily reflect TI's views; see TI's [Terms of Use](#).

## 9.5 Trademarks

Discovery™ is a trademark of Texas Instruments.

TI E2E™ is a trademark of Texas Instruments.

DLP® is a registered trademark of Texas Instruments.

All trademarks are the property of their respective owners.

## 9.6 Electrostatic Discharge Caution



This integrated circuit can be damaged by ESD. Texas Instruments recommends that all integrated circuits be handled with appropriate precautions. Failure to observe proper handling and installation procedures can cause damage.

ESD damage can range from subtle performance degradation to complete device failure. Precision integrated circuits may be more susceptible to damage because very small parametric changes could cause the device not to meet its published specifications.

## 9.7 Glossary

[TI Glossary](#)

This glossary lists and explains terms, acronyms, and definitions.

## 10 Revision History

Changes from Revision D (July 2023) to Revision E (May 2025)	Page
• Changed Window Transmission .....	<a href="#">1</a>
• Changed Array Fill Factor .....	<a href="#">1</a>
• Changed Thermal Metric text.....	<a href="#">15</a>
• Changed micromirror array optical efficiency .....	<a href="#">22</a>
• Changed micromirror array fill factor .....	<a href="#">22</a>
• Changed micromirror surface reflectivity .....	<a href="#">22</a>

---

**Changes from Revision C (February 2017) to Revision D (July 2023)** **Page**

- Changed micromirror switching time typical value from 13µs to 12.5µs and removed 22µs Max value..... [22](#)
  - Changed Thermal Test Point Location drawing to the current thermal test point numbering convention..... [36](#)
- 

## 11 Mechanical, Packaging, and Orderable Information

The following pages include mechanical, packaging, and orderable information. This information is the most current data available for the designated devices. This data is subject to change without notice and revision of this document. For browser-based versions of this data sheet, refer to the left-hand navigation.

**PACKAGING INFORMATION**

Orderable part number	Status (1)	Material type (2)	Package   Pins	Package qty   Carrier	RoHS (3)	Lead finish/ Ball material (4)	MSL rating/ Peak reflow (5)	Op temp (°C)	Part marking (6)
<a href="#">DLP9500UVFLN</a>	Active	Production	CLGA (FLN)   355	12   TRAY NON-STD	Yes	NIPDAU	N/A for Pkg Type	20 to 30	
DLP9500UVFLN.B	Active	Production	CLGA (FLN)   355	12   TRAY NON-STD	Yes	NIPDAU	N/A for Pkg Type	20 to 30	

(1) **Status:** For more details on status, see our [product life cycle](#).

(2) **Material type:** When designated, preproduction parts are prototypes/experimental devices, and are not yet approved or released for full production. Testing and final process, including without limitation quality assurance, reliability performance testing, and/or process qualification, may not yet be complete, and this item is subject to further changes or possible discontinuation. If available for ordering, purchases will be subject to an additional waiver at checkout, and are intended for early internal evaluation purposes only. These items are sold without warranties of any kind.

(3) **RoHS values:** Yes, No, RoHS Exempt. See the [TI RoHS Statement](#) for additional information and value definition.

(4) **Lead finish/Ball material:** Parts may have multiple material finish options. Finish options are separated by a vertical ruled line. Lead finish/Ball material values may wrap to two lines if the finish value exceeds the maximum column width.

(5) **MSL rating/Peak reflow:** The moisture sensitivity level ratings and peak solder (reflow) temperatures. In the event that a part has multiple moisture sensitivity ratings, only the lowest level per JEDEC standards is shown. Refer to the shipping label for the actual reflow temperature that will be used to mount the part to the printed circuit board.

(6) **Part marking:** There may be an additional marking, which relates to the logo, the lot trace code information, or the environmental category of the part.

Multiple part markings will be inside parentheses. Only one part marking contained in parentheses and separated by a "~" will appear on a part. If a line is indented then it is a continuation of the previous line and the two combined represent the entire part marking for that device.

**Important Information and Disclaimer:** The information provided on this page represents TI's knowledge and belief as of the date that it is provided. TI bases its knowledge and belief on information provided by third parties, and makes no representation or warranty as to the accuracy of such information. Efforts are underway to better integrate information from third parties. TI has taken and continues to take reasonable steps to provide representative and accurate information but may not have conducted destructive testing or chemical analysis on incoming materials and chemicals. TI and TI suppliers consider certain information to be proprietary, and thus CAS numbers and other limited information may not be available for release.

In no event shall TI's liability arising out of such information exceed the total purchase price of the TI part(s) at issue in this document sold by TI to Customer on an annual basis.

REVISIONS			
REV	DESCRIPTION	DATE	APPROVED
A	ECO 2055418, INITIAL RELEASE	2/28/05	M. AVERY
B	ECO 2150560, ADD NOTE 15.	05/12/15	M. AVERY
C	ECO 2179667, DELETE NOTE 7.	02/18/19	B. HASKETT
D	ECO 2183329, UPDATE NOTE 14 FOR UV WINDOWS.	09/27/19	B. HASKETT

NOTES: UNLESS OTHERWISE SPECIFIED:

- 1 INTERPRET DIMENSIONS IN ACCORDANCE WITH ASME Y14.5M-1994.
- 2 DATUM A (SYSTEM INTERFACE PLANE) ESTABLISHED BY THREE DATUM AREAS SHOWN IN VIEW A (SHEET 2).
- 3 DATUM B ESTABLISHED BY TWO DATUM AREAS SHOWN IN VIEW A (SHEET 2).
- 4 DATUM C ESTABLISHED BY DATUM AREA SHOWN IN VIEW A (SHEET 2).
- 5 LOCALIZED BACKSIDE SURFACE FLATNESS APPLIES TO ENTIRE SURFACE.
- 6 SUBSTRATE INDEX MARK, BACK INDEX PAD, SYMBOLIZATION PAD, SEAL RING, AND WINDOW FRAME TO BE ELECTRICALLY CONNECTED TO VSS PLANE IN SUBSTRATE.
- 7 (DELETED)
- 8 ROTATION ANGLE OF DMD ACTIVE ARRAY IS A REFINEMENT OF THE LOCATION TOLERANCE AND IS THE MAXIMUM VALUE ALLOWED.
- 9 SUBSTRATE EDGE PERPENDICULARITY TOLERANCE APPLIES TO ENTIRE SURFACE.
- 10 DIE PARALLELISM TOLERANCE APPLIES TO DMD ACTIVE ARRAY ONLY.
- 11 DIE HEIGHT TOLERANCE APPLIES TO CENTER OF DMD ACTIVE ARRAY ONLY.
- 12 DMD ACTIVE ARRAY ROTATION AND LOCATION DIMENSIONS ARE RELATED TO DATUM A (PRIMARY), DATUM B (SECONDARY), AND DATUM C (TERTIARY).
- 13 WINDOW SHALL BE ORIENTED SUCH THAT I.D. MARK ALIGNS WITH SUBSTRATE INDEX MARK AS SHOWN.
- 14 n AND ? ARE WILD CARD CHARACTERS. nn=25 FOR STANDARD VISIBLE WINDOWS; nn=32 FOR UV-TRANSMISSIVE WINDOWS. ? CAN BE ANY LETTER.
- 15 SUBSTRATES PLATED WITH Ni/Au SHALL HAVE THE THREE-DIGIT NUMERICAL MARKING IN THE SYMBOLIZATION PAD, AS SHOWN. SUBSTRATES WITH Ni/Pd/Au SHALL HAVE THE SAME MARKING, BUT ROTATED UPSIDE-DOWN.

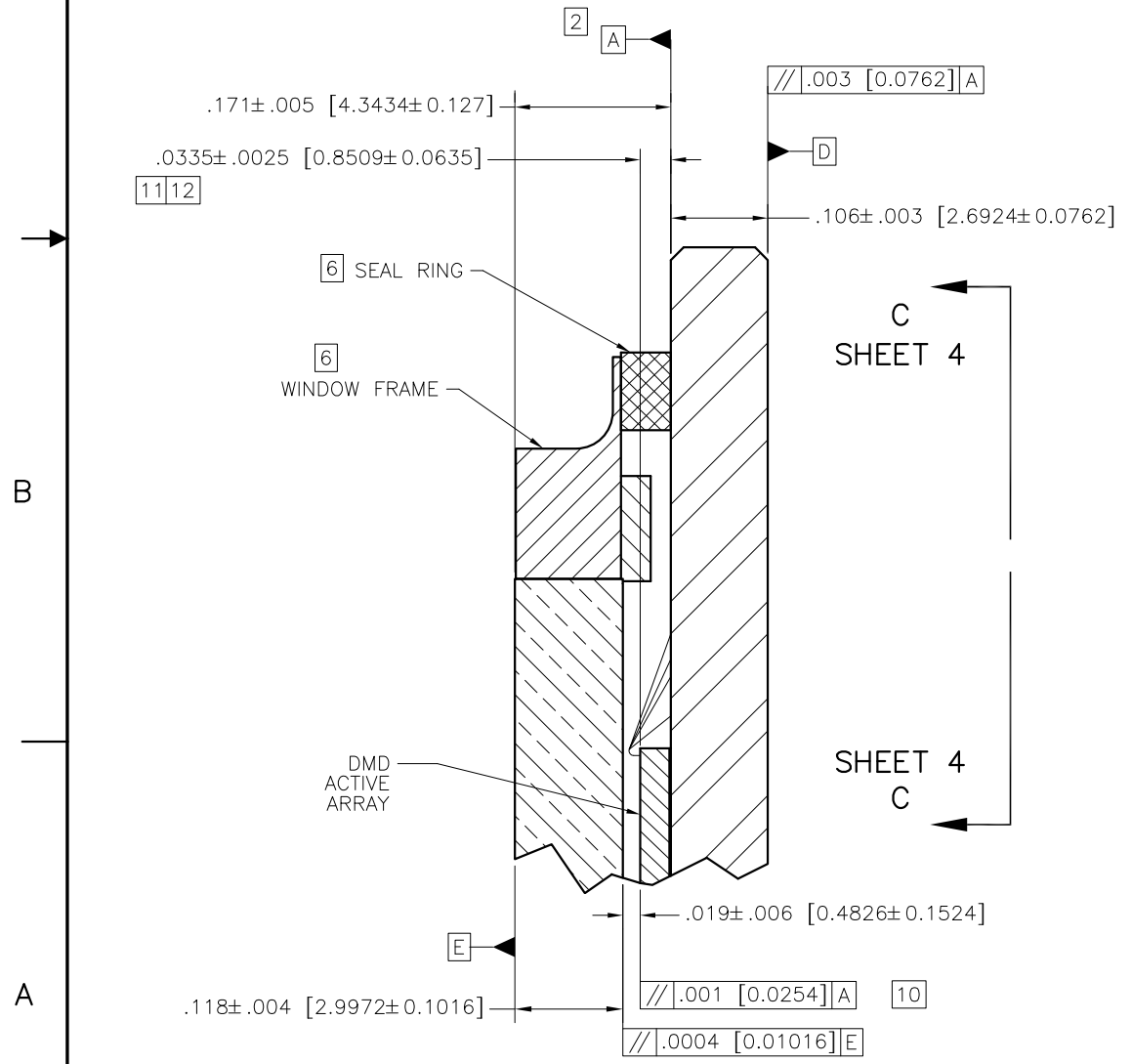

SECTION F-F  
SCALE 10/1

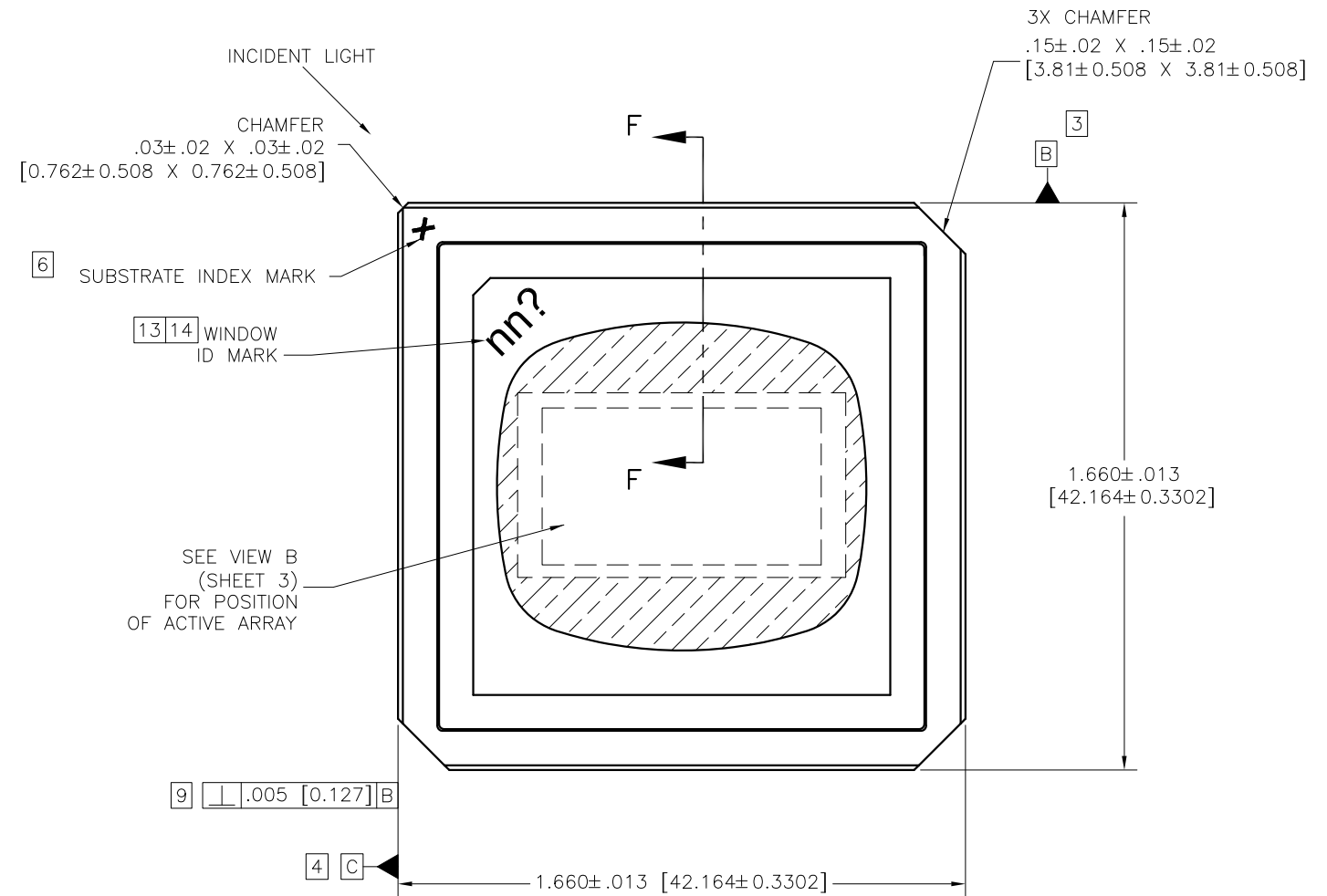

-1	ITEM	PART OR IDENTIFYING NUMBER	NOMENCLATURE OR DESCRIPTION	NOTES
QTY	NO			
PARTS LIST				
			DWN M. AVERY DATE 2/28/05	<p>ICD, MECHANICAL, DMD .95" 1080p TYPE A (FLN PACKAGE)</p>
			ENGR M. AVERY 2/28/05	
			QA	
			APVD	
				SIZE D DRAWING NO 2506491 REV D
				SCALE 4/1 SHEET 1 OF 4

THIRD ANGLE PROJECTION	NONE	0314DA
APPLICATION	NEXT ASSY	USED ON

HOLE TOLERANCE		
.013	.126	.251
THRU -.004	THRU -.005	THRU -.006
.129	.250	.500
THRU -.001	THRU -.001	THRU -.001
.501	.751	1.001
THRU -.008	THRU -.010	THRU -.012
.750	1.000	2.000

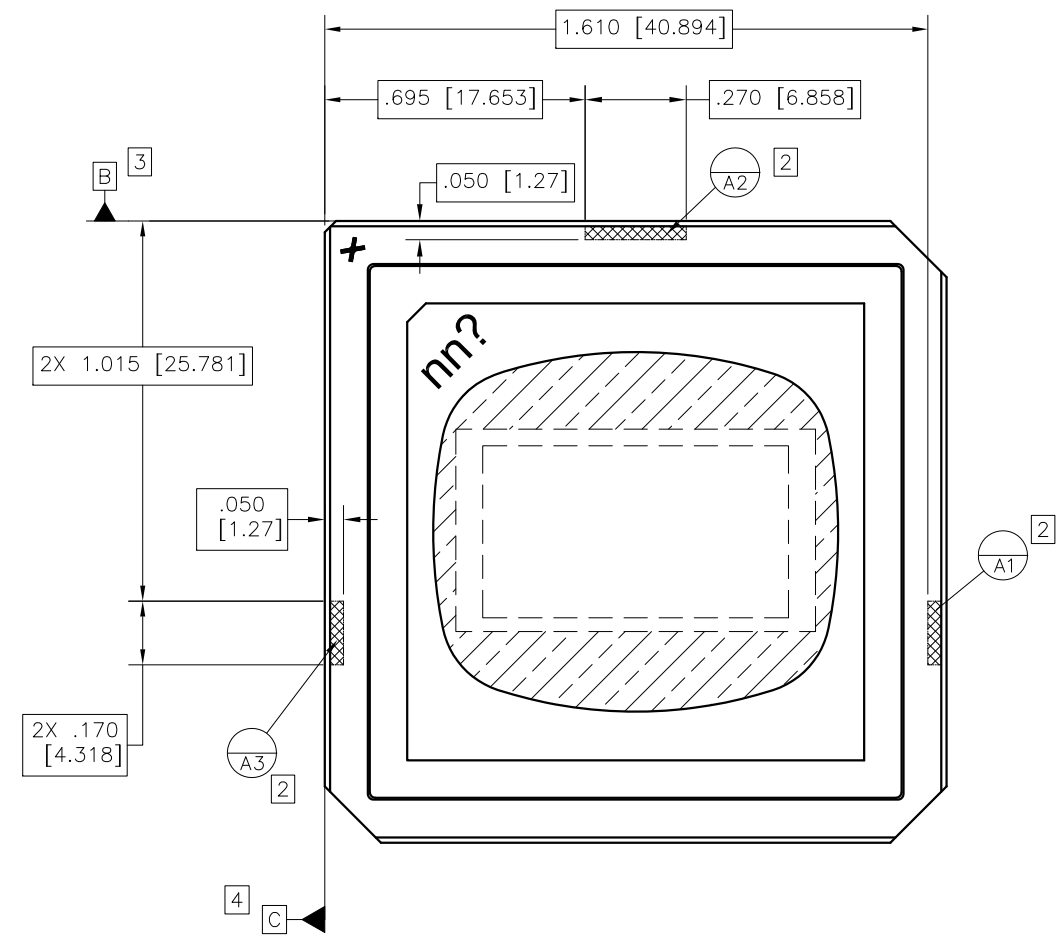
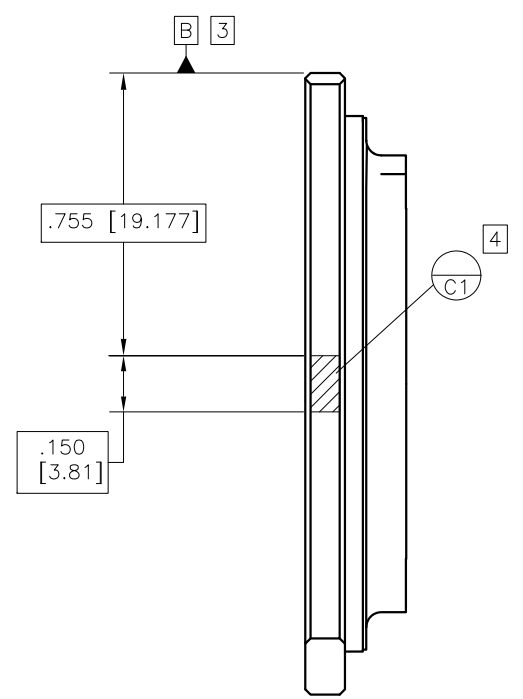
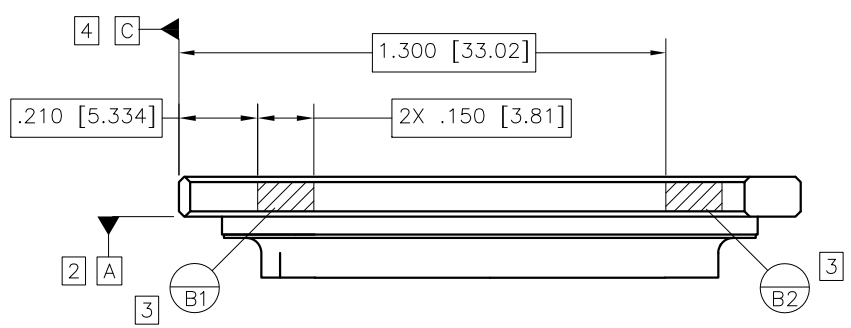

VIEW A (SHEET 1 NOTES)  
DATUM A, B AND C DETAILS

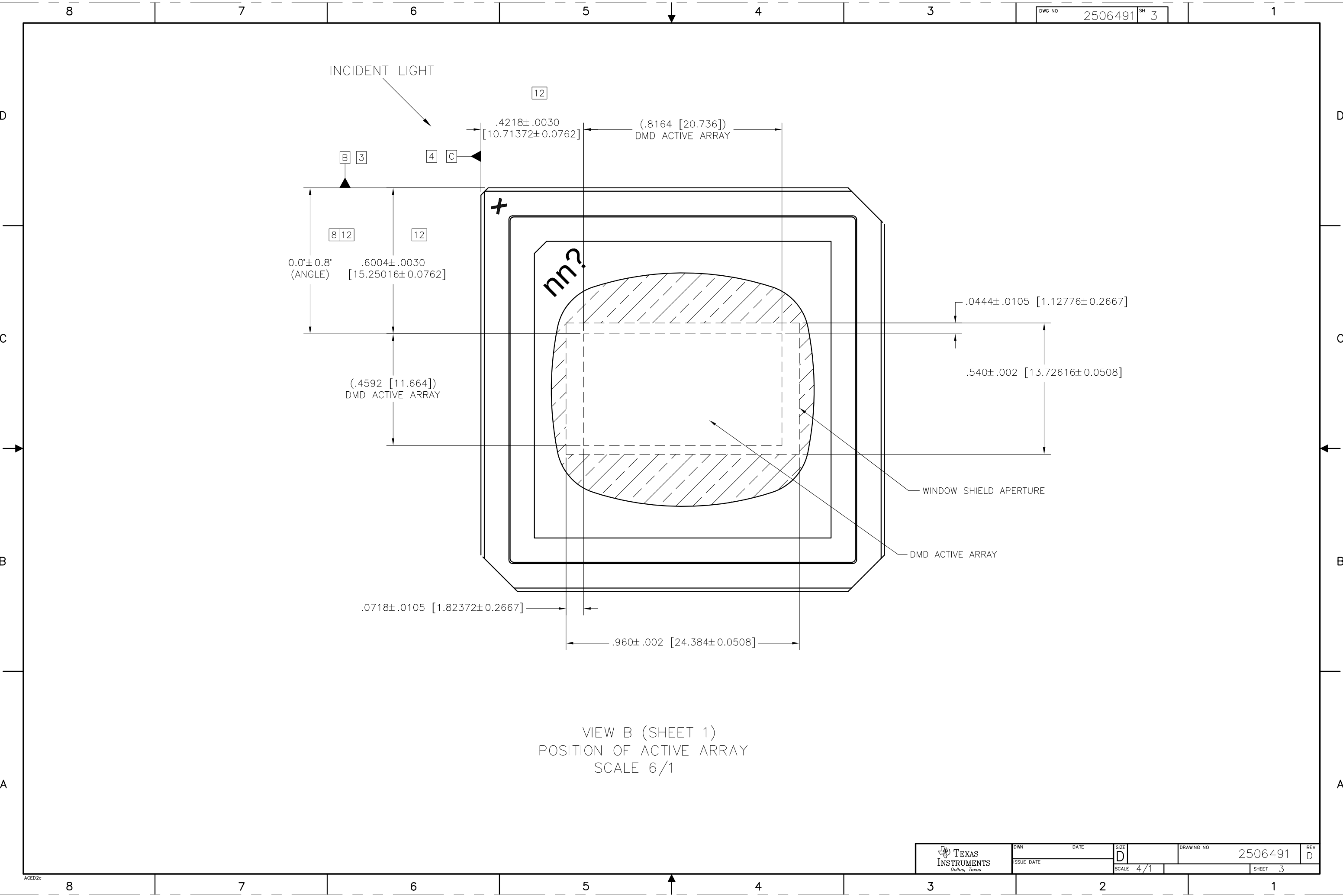

VIEW B (SHEET 1)  
POSITION OF ACTIVE ARRAY  
SCALE 6/1

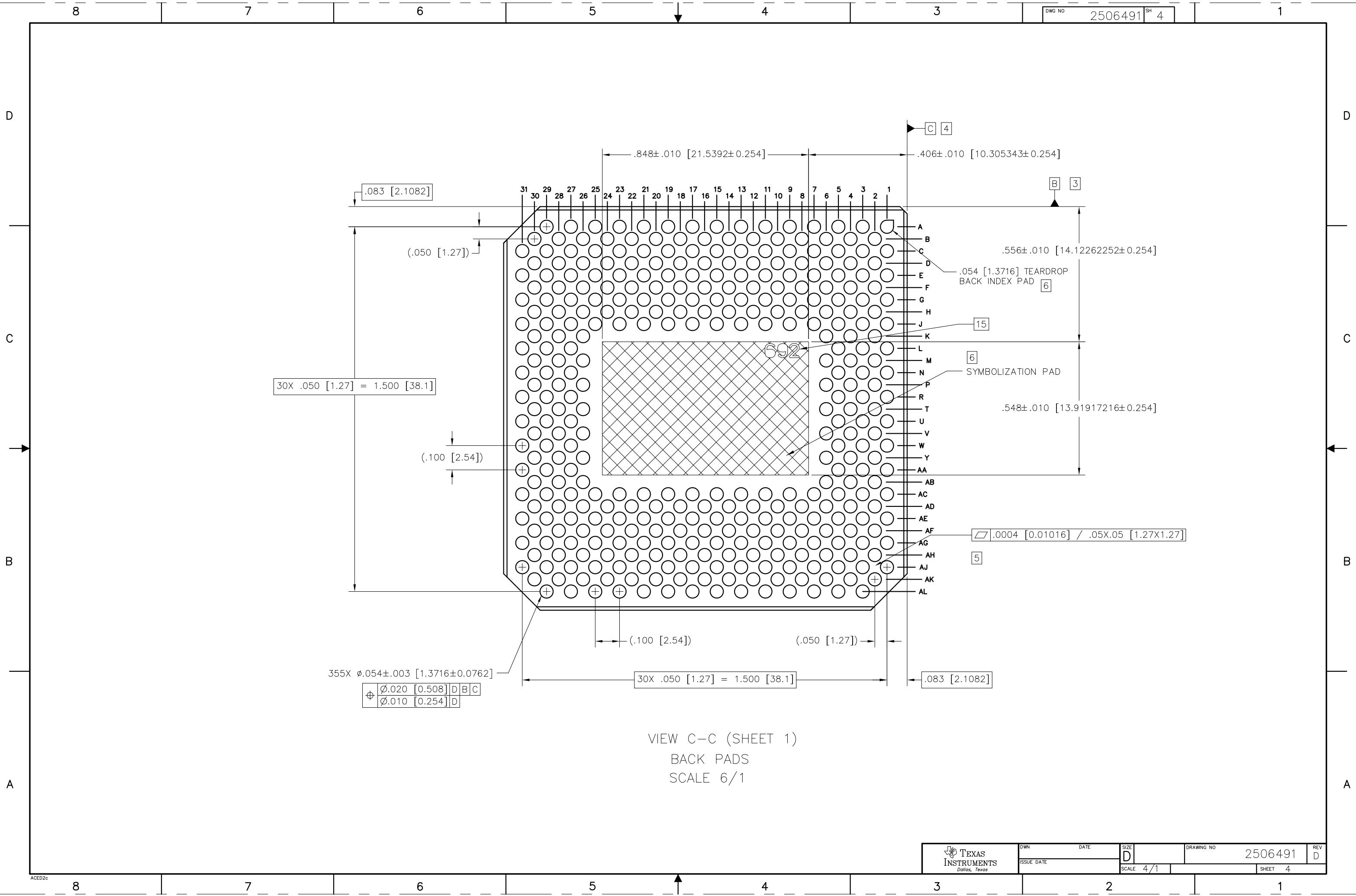

30X .050 [1.27] = 1.500 [38.1]

.0004 [0.01016] / .05X.05 [1.27X1.27]

355X ø.054 ± .003 [1.3716 ± 0.0762]

ø	ø.020	[0.508]	D	B	C
	ø.010	[0.254]	D		

VIEW C-C (SHEET 1)  
BACK PADS  
SCALE 6/1

## IMPORTANT NOTICE AND DISCLAIMER

TI PROVIDES TECHNICAL AND RELIABILITY DATA (INCLUDING DATASHEETS), DESIGN RESOURCES (INCLUDING REFERENCE DESIGNS), APPLICATION OR OTHER DESIGN ADVICE, WEB TOOLS, SAFETY INFORMATION, AND OTHER RESOURCES "AS IS" AND WITH ALL FAULTS, AND DISCLAIMS ALL WARRANTIES, EXPRESS AND IMPLIED, INCLUDING WITHOUT LIMITATION ANY IMPLIED WARRANTIES OF MERCHANTABILITY, FITNESS FOR A PARTICULAR PURPOSE OR NON-INFRINGEMENT OF THIRD PARTY INTELLECTUAL PROPERTY RIGHTS.

These resources are intended for skilled developers designing with TI products. You are solely responsible for (1) selecting the appropriate TI products for your application, (2) designing, validating and testing your application, and (3) ensuring your application meets applicable standards, and any other safety, security, regulatory or other requirements.

These resources are subject to change without notice. TI grants you permission to use these resources only for development of an application that uses the TI products described in the resource. Other reproduction and display of these resources is prohibited. No license is granted to any other TI intellectual property right or to any third party intellectual property right. TI disclaims responsibility for, and you fully indemnify TI and its representatives against any claims, damages, costs, losses, and liabilities arising out of your use of these resources.

TI's products are provided subject to [TI's Terms of Sale](#), [TI's General Quality Guidelines](#), or other applicable terms available either on [ti.com](#) or provided in conjunction with such TI products. TI's provision of these resources does not expand or otherwise alter TI's applicable warranties or warranty disclaimers for TI products. Unless TI explicitly designates a product as custom or customer-specified, TI products are standard, catalog, general purpose devices.

TI objects to and rejects any additional or different terms you may propose.

Copyright © 2025, Texas Instruments Incorporated

Last updated 10/2025